



SC&PV - Engg DEPT.

Phone No.080-26998991

NOTICE INVITING TENDER

1. TENDER NUMBER(RFQ) : EDN: PVSS: Medak: 16MW:Module-tilting:01, Date: 25.10.2017
2. NAME OF WORK : Seasonal tilting of solar PV module structures at BEL 16MW solar PV Plant, OFMK, Medak, Telangana.
3. ESTIMATED COST : Rs.28.00 Lakhs (APPROX.) excluding GST
4. EARNEST MONEY DEPOSIT : Rs. 66,500 /-
5. SECURITY DEPOSIT : 50% of SD shall be submitted before start of work; Balance will be recovered from running Bills at a rate of 10%. (SD= 5% of the Contract value); 50% of SD will be released after completion of all the works and remaining 50% after 6 months from the date of completion of all the works.(SD does not carry any interest)
6. LAST DATE AND TIME FOR THE SUBMISSION OF DULY FILLED IN TENDER DOCUMENT : **Before 01:00 P.M On 09.11.2017**
8. PLACE OF SUBMISSION OF TENDER DOCUMENT : Smt. Punam Mishra , Sr. Manager (SC&PV- Engg 5th Floor, New Engineering Building BHEL- Electronics Division Mysore Road, Bangalore -560 026.
9. ADDRESS TO BE SUPERSCRIBED : ON TENDER ENVELOPE : Smt. Punam Mishra , Sr. Manager (SC&PV- Engg) 5th Floor, New Engineering Building, BHEL- Electronics Division, Mysore Road, Bangalore-560026.
10. DATE AND TIME OF TECHNICAL BID OPENING : **ON 09.11.2017 AT 01:30 PM**

NOTE: The Tenderer shall return the duly filled in Tender document after affixing Signatures & seal on all pages and submit.

ಪುನಮ್ ಮಿಶ್ರಾ, ಹಿರಿಯ ವ್ಯವಸ್ಥಾಪಕರು/ಎಸ್.ಸಿ. & ಪಿ.ವಿ.-ಎಂಜಿ.
ಪುನಮ್ ಮಿಶ್ರಾ, ಹಿರಿಯ ಇಂಜಿನಿಯರ್/ಎಸ್.ಸಿ. & ಪಿ.ವಿ.-ಎಂಜಿ.
PUNAM MISHRA, SR. MANAGER/SC & PV-ENGG.
BHEL-EDN, MYSORE ROAD, BANGALORE-560026.

CONTACTOR (SIGN & SEAL)



BHARAT HEAVY ELECTRICALS LTD, ELECTRONICS DIVISION, BANGALORE-26
TENDER NO. : EDN: PVSS: Medak: 16MW:Module-tilting:01, Dt 25.10.2017

CONTENTS

Part-1 bid

Technical-cum-commercial bid

Section-1	Instructions on bid submission / bid opening along with pre-qualification criteria
Section-2	Particulars of technical-cum-commercial bid (to be filled by bidder in the marked spaces)
Section-3	Additional instructions to the bidder
Section-4	General conditions of the contract
Section-5	Safety undertaking format (to be submitted by the bidder in their letter head)
Enclosure-A	Form of tenderer
Enclosure-B	CLAUSE 58 OF GENERAL CONDITIONS OF CONTRACT
Annexure-1	EFT Form
Annexure-2	Drawing of MMS for BEL Medak.

Part-2 bid

Section-6	Price bid
-----------	-----------

ಪುನಮ್ ಮಿಶ್ರಾ, ಹಿರಿಯ ವ್ಯವಸ್ಥಾಪಕರು/ಎಸ್.ಸಿ. & ಪಿ.ಎಂ.-ಎಂಜಿ.
PUNAM MISHRA, SR. MANAGER/SC & PV-ENGG.
BHEL-EDN, MYSORE ROAD, BANGALORE-560026.

CONTACTOR (SIGN & SEAL)



Part-1 TECHNICAL-CUM-COMMERCIAL BID **(To be furnished by the Bidders)**

Section-1: Instructions on bid submission/opening along with pre-qualification criteria

1	Description of Work	Seasonal tilting of solar PV module structures at BEL 16MW solar PV plant, Ordinance Factory, Yeddumailaram village, Medak district, Telangana for a period of 5 years (10 tilting cycles).
2	Bid submission/opening details	<p>(a) Bidder shall submit the bid in two-parts: technical-cum-commercial bid (part-1) and price bid (part-2).</p> <p>(b) Both the part-1 and part-2 shall be submitted in separately sealed envelopes to the address mentioned in the NIT on or before the due date/ time.</p> <p>(c) Technical-cum-commercial bid (part-1): NIT ref, NIT date, description of work as above shall be superscribed on the envelope. “Technical-cum-commercial bid (Part-1)” shall also be mentioned on the envelope.</p> <p>(d) Price bid (part-2): NIT ref, NIT date, description of work as above shall be superscribed on the envelope. “Price bid (Part-2)” shall also be mentioned on the envelope.</p> <p>(e) Part-I, Part-II, EMD (sealed covers) should be put in outer envelope and super scribing the Name of work and Name & Address of the Tenderer.</p> <p>(f) In case BHEL decides to open price-bid in lieu of reverse auction, date/time of opening of price-bid will be intimated to those bidders who get qualified in Part-1 bid. Bidders desiring to be present during the price-bid opening shall depute their representatives. Authorization letter from their company indicating the name of their representative shall be presented to BHEL well in advance.</p> <p>(g) All pages of both the bid documents shall be signed, with seal, by the bidder/contractor.</p>
3	Pre-qualification criteria	<p>Bidder shall essentially comply with all the pre-qualification criteria as below to get qualified for further evaluation of technical-cum-commercial/ price bids by BHEL. In other words, bids of those vendors not qualifying these pre-qualification criteria will be rejected and the same will be intimated to the bidder:</p> <p>(a) Bidder shall have experience in erection and/or tilting of the module mounting structures of solar photovoltaic plants (roof-top or ground-mounted). He shall have completed minimum cumulative 1MW capacity during past three years with reference to tender opening date. As evidence to this, work orders and completion certificates from the clients shall be submitted along with technical-cum-commercial bid (part-1).</p> <p>(b) Bidder shall essentially indicate their GST number, PAN number and NEFT details of bank in the technical-cum-commercial bid (part-1).</p> <p>(c) Bidder must have carried out works of value at least Rs 6L during 2016-17. Suitable evidence shall be enclosed along with part-1 bid.</p>
4	Documents to be submitted along with part-1, part-2 bids	<p>A. Documents to be submitted in part-1 envelope:</p> <ol style="list-style-type: none">1. Evidence documents as per pre-qualification criteria above2. Safety undertaking on letter head of the bidder as per format in the NIT3. All the pages of Part-1 bid of NIT to be duly signed by the bidder with seal including the particulars of technical-cum-commercial bid duly filled-in.4. BHEL drawing of module mounting structure: signed by bidder with seal <p>B. Documents to be submitted in part-2 envelope:</p> <p>Price-bid duly filled-in, signed with seal</p>



Section-2: Particulars of technical-cum-commercial bid (to be filled by bidder in the marked spaces)

1	Description of Work	Seasonal tilting of solar PV module structures at BEL 16MW solar PV plant, Ordinance Factory, Yeddumailaram village, Medak District, Telangana
2	Technical specification	<p>Solar PV modules are mounted on GI structures as per enclosed drawing 3-679-05-00849. There are 2893 structures each mounted with 24 Nos of solar PV modules. Among these structures, 2713 located on 15MW side and 180 on 1MW side of the plant. Each structure has four column legs (CL) each with a welded plate (PL2) that is fastened to two bracings BR1 and BR1a using SS316 fasteners – M10 bolts/nuts/plain/spring washers. There are 8 sets of such fasteners per structure. Each BR1/BR1a bracing has two holes for such fastening. Whereas one hole is meant for module mounting angle of 2 deg, the other one is for 33 deg.</p> <p>Work involves (a) removing the 8 sets of fasteners from the existing hole positions, (b) with appropriate balancing of the entire structure, shifting the fasteners to the other hole positions, and (c) tightening the bolts/nuts/washers using an appropriate wrench to a torque of 22 Nm approximately. Exact torque value will be intimated to the contractor after awarding of work.</p> <p>The structures shall be tilted two times in a year for the seasons: (a) Apr-Sep, 2 deg and (b) Oct-Mar, 33 deg. Tilting shall be completed before commencement of the respective seasons.</p> <p>Max allowable period for each cycle of tilting shall be 15 days. Based on this criterion, the other factors such as number of semi-skilled persons per structure (each team), number of such concurrent teams deployed, number of working hours per day, time period for tilting of each structure shall be selected by the bidder/contractor.</p> <p>Contractor shall provide each team with necessary sets of spanners, torque wrenches.</p> <p>Working persons (labour) shall be provided with necessary personal protective equipments: boots, gloves etc so as to ensure their safety during the working.</p> <p>All necessary accessories such as supporting stands etc shall be provided by the contractor so as to prevent (a) damage to the modules/structures, as well as, (b) accident/ injury to the working persons.</p>
3	Site visit prior to submission of the bids	It is the responsibility of the bidder to ensure appropriate understanding of the technical requirement, site location and site conditions. Accordingly, it is recommended that the bidder shall visit the site prior to submission of bids.
4	Work completion time	Max 15 days per cycle of tilting



BHARAT HEAVY ELECTRICALS LTD, ELECTRONICS DIVISION, BANGALORE-26
TENDER NO. : EDN: PVSS: Medak: 16MW:Module-tilting:01, Dt 25.10.2017

5	Penalty	10% of the contract value pertaining to the concerned year/ seasonal cycle of tilting if the work completion is delayed beyond 15 days, unless the delay is accountable to rains or any other applicable natural calamity as duly certified by BHEL engineer.
6	Payment terms	(a) No advance payments (b) Payment will be 30 days from the date of receipt of the BHEL-certified bill at BHEL-EDN. Bill shall be certified by BHEL engineer. (c) Price variation clause after awarding of work not applicable.
7	Validity of price bid	90 days from the date of tender opening.
8	Statutory conditions/ documents applicable	(a) Workmen compensation insurance policy with validity during the period of execution of work shall be submitted along with the bills. (b) Wages to the working persons as per applicable minimum wages act (c) PF and ESI – not applicable
9	Other commercial conditions	(a) Transportation of persons/ materials, stay/ accommodation/ food/ drinking water for the workings persons deployed at site shall be the responsibility of the contractor. Accordingly, all such charges shall be borne by them. (b) Electrical power for the work, if applicable, shall be arranged by the contractor at their own expense. (c) Construction water, if applicable, shall be arranged by the contractor at their own expense. (d) All the associated materials/ equipments/ tools/ instruments etc shall be the responsibility of the contractor at their own expense.
10	Name of the bidding company #	
11	Address of the bidder #	
12	Contact details of the bidder #	(a) Landline phone No: (b) Name of the contact person: (c) Mobile number:
13	EMD Particulars #	
14	GST Number #	
15	PAN number #	
16	NEFT details of bank #	

Note: # marked particulars to be filled by the bidder.

For S.No:13, Earnest Money Deposit of Rs 66,500 /- in the form of DD in favor of BHEL-EDN should be submitted in a separate sealed cover.

For S.no: 14 and 15 , a copy has to be enclosed.

For S.No: 16, EFT form has to be filled up as per the Annexure.

ಪುನಮ್ ಮಿಶ್ರಾ, ಹಿರಿಯ ವ್ಯವಸ್ಥಾಪಕರು/ಎಸ್.ಸಿ. & ಪಿ.ವಿ.-ಎಂಜಿ.
ಪುನಮ ಮಿಶ್ರಾ, ಸಿ.ಐ. ಪ್ರಾಜೆಕ್ಟ್/ಎಸ್.ಸಿ. & ಪಿ.ವಿ.-ಎಂಜಿ.
PUNAM MISHRA, SR. MANAGER/SC & PV-ENGG.
BHEL-EDN, MYSORE ROAD, BANGALORE-560026.

CONTACTOR (SIGN & SEAL)



Section-3: Additional instructions to the bidder

- 1) All entries in tender documents should be in one ink (preferably blue ink). Erasing and overwriting is not permitted. All corrections should be duly signed by the bidder.
- 2) Bidders shall fill in all the required particulars in the blank space provided for filling purpose.
- 3) Bidders shall submit the tender documents with their signature and seal on every page.
- 4) For every item of price bid, unit rate shall be quoted in both figures and words in Indian currency i.e. rupees and paisa. In case the figure differs from word, the lower of the two will be taken as the final and shall be binding on the bidder.
- 5) Quantity of each item shown in the bill of quantities of the NIT price-bid document are only approximate. They are given as a guide for the purpose of tendering only and are liable for variation and alteration at the discretion of the competent authority of BHEL. The actual work quantity executed under each item shall be measured and certified by BHEL engineer. Rates for the actual work will be the same as per the work order issued by BHEL.
- 6) In the event of the bids being submitted by a firm, the bids must be signed separately and legibly by each partner or member of the firm or in their absence, by the person holding the power of Attorney on behalf of firm concerned. In the latter case, a copy of the power of Attorney duly attested by the Gazetted Officer must accompany the tender.
- 7) BHEL reserves the right to reject any or all the bids received or accept any bid or part thereof without assigning reason thereof. In the case of acceptance of a part of bid, the time for completion may also be reduced to the extent considered necessary by the accepting authority.
- 8) Bids that are conditional/ unsigned/ incomplete, bids that are not in accordance with the NIT conditions and those not submitted in the prescribed formats are liable to be rejected.
- 9) Bids submitted by speed post or courier service shall be posted with due consideration of any delay in postal delivery. Bids received after the due date and time of opening are liable to be rejected.
- 10) Any covering letter and comments of the bidder should be submitted along with the offer.
- 11) Should the bidder have a relative (or) in the case of firm or company, should any of their shareholders have a relative, employed in Bharat Heavy Electricals Limited, the authority inviting bids shall be informed of this fact at the time of submission of the bid, failing which the bid may be disqualified or if such fact subsequently comes to light.
- 12) For reimbursement of Earnest Money Deposit, the tenderer should fill the enclosed EFT form, obtain the Banker's signature and also enclose a photocopy of cancelled cheque leaf.
- 13) Unless the bidder whose tender is accepted signs contract agreement within seven days (7 days) of the date of the order directing to do so, the amount of Earnest Money already deposited by bidder will be forfeited and acceptance of the tender withdrawn.



Section 4: General conditions of the contract

- 1) Construction power and water, if applicable and required for the work, shall be organized by the contractor at their own cost.
- 2) All machinery such as cranes, hydra, JCBs, forklifts, transport trucks, trolleys etc necessary for the work shall be organized by the contractor at their own cost.
- 3) All necessary tools and tackles such as spanners, torque wrenches, support stands, other accessories etc required for the work shall be organized by the contractor at their own cost.
- 4) Contractor shall make their own arrangements for necessary food, drinking water and accommodation for their working persons/ labour deployed at the site. Similarly, food and drinking water required at the site, during the construction operations, shall also be in scope of contractor.
- 5) Contractor shall organize all necessary steps to meet statutory requirements such as workmen compensation policy etc and also ensure compliance with relevant acts such as minimum wages act, income tax act, workmen/employee insurance act etc for their labour deployed at site.
- 6) Contractor shall maintain labour register, with name, age, salary, attendance details etc at the site.
- 7) Contractor shall use danger boards, wherever required, to ensure safety of the persons during work at site.
- 8) Contractor shall adhere to all necessary safety norms such as use of helmet, goggles, hand gloves, gumboots, aprons etc. It is the ultimate responsibility of the contractor in all respect to prevent accidents at the site and safeguard their labour from accidents.
- 9) Contractor shall, at the completion of every work, clear off the debris, which resulted out of the work.
- 10) Contractor shall carry out the work without causing inconvenience to other contract groups at the site. In case of conflicts with other groups, contractor shall ensure that the matter is resolved at once amicably so that the progress of work is not affected.
- 11) Any damages on the building, structures etc attributable to the acts of labour / employees of contractor shall be rectified and made good by the contractor at their own cost.
- 12) No child labour shall be employed for execution of the present contract.
- 13) Any miscellaneous materials/ accessories, which are found essential for technical completion of the contract but not mentioned explicitly in this specification, shall be deemed to be included in the specification. Accordingly, such materials shall be included by the contractor as part of the offer.
- 14) Deviations, if any, shall be discussed with BHEL engineers and implementation shall be taken up only after approval from BHEL /BEL.
- 15) Contractor shall submit status report, on daily basis, to BHEL on the progress of the work.
- 16) Persons of the contractor working at site shall be deemed to be aware of damages and the risks incidental to the site/land/working conditions of the ordnance factory (OFMK) from time to time and BHEL/BEL shall not be responsible for any injury to the persons of contractor arising therefrom.
- 17) Contractor shall insure all his labourers and materials. Any claim by his Employees for damages shall be settled by the Contractor even if action is against BHEL or to reimburse the legal expenses incurred by BHEL.
- 18) No extra items of work shall be carried out by the contractor other than those authorized to do so in writing by BHEL. For any such items of work executed as per instructions of BHEL, the rates will be fixed on the basis of BHEL terms and conditions.
- 19) In case the work is not completed as per BHEL scope due to any unforeseen reasons, contractor has to complete the job at later stage without any extra charge. No overturn charges shall be paid in case of extension of work schedule.



20) SECURITY DEPOSIT

Upon acceptance of the tender, the successful tenderer shall remit the security deposit with Bharat Heavy Electricals Ltd within the time as specified in the Letter of Intent.

The rate of Security Deposit will be as below:

The total amount of Security Deposit will be 5% of the contract value. EMD of the successful tenderer shall be converted and adjusted towards the required amount of Security Deposit.

The contractor should submit the Security Deposit before the start of the work by

- i) Cash (as permissible under the income Tax Act).
- ii) Pay order, demand draft in favour of BHEL.
- iii) Local cheques of scheduled banks, subject to realization.
- iv) Securities available from Post Offices such as National Saving Certificates, Kisan Vikas Patras etc.,(Certificate should be held in the name of contractor furnishing the security and duly pledged in favour of BHEL and discharged on the back).
- v) Bank Guarantee from scheduled Banks/Public financial Institutions as defined in the companies Act subject to a maximum of 50% of the total security deposit value. The balance 50% has to be remitted either by cash or in the other form of security. The Bank Guarantee format should have the approval of BHEL.
- vi) Fixed Deposit Receipt issued by scheduled Banks/Public Financial Institutions as defined in the Companies Act. The FDR should be in the name of the contractor, A/C BHEL, duly discharged on the back.
- vii) Security Deposit can also be recovered at the rate of 10% from the running bills. However in such cases at least 50% of the Security Deposit should be collected before start of the work and balance 50% may be recovered from the running bills.
- viii) EMD of the successful tenderer shall be converted and adjusted against the Security Deposit. The Security Deposit shall not carry any interest.

NOTE: Accepting of Security Deposit against Sl. No. (iv) and (vi) above will be subject to hypothecation or endorsement on the documents in favour on BHEL. However, BHEL will not be liable or responsible in any manner for the collection of interest or renewal of the documents or in any other matter connected therewith.

For extra items of work and deviated quantities, security deposit will be recovered at 10% of the value of deviated amount. The security deposit will be released as stipulated under clause 16(IV) of GCC.



BHARAT HEAVY ELECTRICALS LTD, ELECTRONICS DIVISION, BANGALORE-26
TENDER NO. : EDN: PVSS: Medak: 16MW:Module-tilting:01, Dt 25.10.2017

Section-5: Safety undertaking format (to be submitted by the bidder in their letter head)

Date:

To
Bharat Heavy Electricals Limited
Electronics division
Mysore road
Bangalore 560 026

Sir,

Sub: Undertaking to adopt statutory provisions/acts for work safety

Ref: Your NIT ref: EDN:PVSS:Medak:16MW:Module-tilting:01, NIT date: 23.10.2017

We hereby undertake that, if the work is awarded to us, we shall be solely responsible for the work safety and health of our team of engineers/ technicians/ labour etc deployed at project site during the course of mobilization and execution of seasonal tilting of modules at "BEL 16MW solar PV power plant at Ordnance Factory, Yeddumailaram village, Medak district, Telangana". Accordingly, we shall be solely responsible to adopt all applicable statutory provisions/acts related to safety, health, accident prevention, compensations to our team.

Yours sincerely,

(Signature with seal)

For M/s _____

ಪುನಮ್ ಮಿಶ್ರಾ, ಹಿರಿಯ ವ್ಯವಸ್ಥಾಪಕರು/ಎಸ್.ಸಿ. & ಪಿ.ವಿ.-ಎಂಜಿ.
PUNAM MISHRA, SR. MANAGER/SC & PV-ENGG.
BHEL-EDN, MYSORE ROAD, BANGALORE-560026.

CONTACTOR (SIGN & SEAL)



BHARAT HEAVY ELECTRICALS LTD, ELECTRONICS DIVISION, BANGALORE-26
TENDER NO. : EDN: PVSS: Medak: 16MW:Module-tilting:01, Dt 25.10.2017

Enclosure: A

FORM OF TENDER

Having examined the invitation to bid, Instructions to Bidder, General conditions of contract, Specifications tender schedule, Contract drawings and other documents for the above work, we the undersigned, offer to construct, erect complete and maintain the whole of the said in conformity with the said bid documents on the terms and conditions and under the provisions set out or called for in the contract documents at the rates listed in the schedule of unit prices or elsewhere in the contract documents.

We undertake if our bid is accepted, to commence the works within 7 days from the date of issue of award and to complete and delivery the whole of the works comprised in the contract as per the time schedule agreed to the contract document.

Until and unless a formal agreement is prepared and executed this bid, together with your award thereof shall constitute a binding contract between us.

ಪುನಮ್ ಮಿಶ್ರಾ, ಹಿರಿಯ ವ್ಯವಸ್ಥಾಪಕರು/ಎಸ್.ಸಿ. & ಪಿ.ಎಂ.-ಎಂಜಿ.
PUNAM MISHRA, SR. MANAGER/SC & PV-ENGG.
BHEL-EDN, MYSORE ROAD, BANGALORE-560026.

CONTACTOR (SIGN & SEAL)



ENCLOSURE: B

CLAUSE 58 OF GENERAL CONDITIONS OF CONTRACT

ARBITRATION:

Except where otherwise provided for in the contract all questions and disputes relating to the meaning of the specifications, designs, drawings and instructions herein before mentioned and as to the quality of workmanship or materials used on the work or has been other as to any other questions, claim, right, matter or thing whatsoever in any way arising out of or relating to the contract, designs, drawings, specifications, estimates, instructions, orders or these conditions or otherwise concerning the works, or the execution or failure to execute the same whether arising during the program progress of the work or after the completion or abandonment thereof shall be referred to the sole arbitration of the Executive Director/General Manager of BHEL and if the Managing Executive Director/General Manager Chief Engineer is unable or unwilling to act, to a as the sole arbitration of some other person appointed by the Executive Director / General Manager, willing to act as such Arbitrator. There will be no objection if the arbitrator so appointed is an employee of BHEL EDN or an employee of any other unit of BHEL and that he had to deal with the matters to which the contract relates and that in the course of its his duties as such he had expressed views on all or any of the matters in dispute or difference. The Arbitrator to whom the to matter is originally referred being transferred or by vacating his office or being unable to act for any reason, such Executive Director / General Manager as aforesaid at the time of such transfer, vacation of office or inability to act, shall appoint account another person to act as arbitrator in accordance with the terms of the contract, such person shall be entitled to proceed with the reference from the stage at which it was left by his predecessor. It is also a term of this contract that no person other than a person appointed by such Executive Director/General Manager or an employee appointed as arbitrator as aforesaid should act as arbitrator and the arbitrator shall give reasons for the award.

Subject as aforesaid the provision of the Arbitration Act, 1940 or any statutory modification or re-enactment thereof and the rules made there under and for the time being in force shall apply to the arbitration proceeding under this clause.

ಪುನಮ್ ಮಿಶ್ರಾ, ಹಿರಿಯ ವ್ಯವಸ್ಥಾಪಕರು/ಎಸ್.ಸಿ. & ಪಿ.ಎ.-ಎಂಜಿ.
ಪುನಮ್ ಮಿಶ್ರಾ, ಹಿರಿಯ ವ್ಯವಸ್ಥಾಪಕರು/ಎಸ್.ಸಿ. & ಪಿ.ಎ.-ಎಂಜಿ.
PUNAM MISHRA, SR. MANAGER/SC & PV-ENGG.
BHEL-EDN, MYSORE ROAD, BANGALORE-560026.

CONTACTOR (SIGN & SEAL)



BHARAT HEAVY ELECTRICALS LTD, ELECTRONICS DIVISION, BANGALORE-26
TENDER NO. : EDN: PVSS: Medak: 16MW:Module-tilting:01, Dt 25.10.2017

It is a term of a contract that the party involving invoking arbitration shall specify the dispute or disputes to be referred to arbitration under this clause together with the amount or amounts claimed in respect of each such dispute.

The arbitrator(s) may from time to time with consent of the parties enlarge extend the time, for making the publishing the awards.

The work under the contract shall, if reasonably possible, continue during the arbitration proceeding and no payment due to or payable to the contractor shall be withheld on account of such proceedings.

The arbitrator shall be deemed to have entered on the reference on the date he issued notice to both the parties fixing the date of the hearing.

The arbitrator shall give a separate speaking award in respect of each dispute or difference referred to him.

The venue of arbitration shall be such place as may be fixed by the arbitrator in his sole discretion.

The award of the arbitrator shall be final, conclusive and binding on all parties to this contract.

ಪುನಮ್ ಮಿಶ್ರಾ, ಹಿರಿಯ ವ್ಯವಸ್ಥಾಪಕರು/ಎಸ್.ಸಿ. & ಪಿ.ವಿ.-ಎಂಜಿ.
ಪುನಮ್ ಮಿಶ್ರಾ, ಹಿರಿಯ ವ್ಯವಸ್ಥಾಪಕರು/ಎಸ್.ಸಿ. & ಪಿ.ವಿ.-ಎಂಜಿ.
PUNAM MISHRA, SR. MANAGER/SC & PV-ENGG.
BHEL-EDN, MYSORE ROAD, BANGALORE-560026.

CONTACTOR (SIGN & SEAL)



**Electronic Funds Transfer (EFT) OR
Paylink Direct Credit Form**

Please Fill up the form in **CAPITAL LETTERS** only.
 TYPE OF REQUEST(Tick one): CREATE CHANGE

BHEL Vendor / Supplier Code:	<input type="text"/>
Company Name :	<input type="text"/>
Permanent Account Number(PAN):	<input type="text"/>
Address	<input type="text"/>
	<input type="text"/>

City: PINCODE STATE

Contact Person(s)	<input type="text"/>
Telephone No:	<input type="text"/>
Fax No:	<input type="text"/>
e-mail id:	<input type="text"/>

1 Bank Name:	<input type="text"/>
2 Bank Address:	<input type="text"/>
	<input type="text"/>
3 Bank Telephone No:	<input type="text"/>
4 Bank Account No:	<input type="text"/>
5 Account Type: Savings/Cash Credit	<input type="text"/>
6 9 Digit Code Number of Bank and branch appearing on MICR cheque issued by Bank	<input type="text"/>
7 Bank swift Code(applicable for EFT only)	<input type="text"/>
8 Bank IFSC code(applicable for RTGS)	<input type="text"/>
9 Bank IFSC code(applicable for NEFT)	<input type="text"/>

- A I hereby certify that the particulars given above are true, correct and complete and that I, as a representative for the above named Company, hereby authorise BHEL, EDN, Bangalore to electronically deposit payments to the designated bank account.
- B If the transaction is delayed or not effected at all for reasons of incomplete or incorrect information, I would not hold BHEL / transferring Bank responsible.
- C This authority remains in full force until BHEL, EDN, Bangalore receives written notification requesting a change or cancellation.
- D I have read the contents of the covering letter and agree to discharge the responsibility expected of me as a participant under ECS / EFT.

Date:

Authorised Signatory:
 Designation:

Telephone NO. with STD Code

Company Seal

Bank Certificate

We certify that _____ has an Account No _____ with us and we confirm that the bank details given above are correct as per our records.

Date: _____ (.....)
 Place: _____ Signature _____

Please return completed form along with a blank cancelled cheque or photocopy thereof to:

Bharath Heavy Electricals Ltd,

Attn:

Electronics Division, Mysore Road,

BANGALORE - 560 026

In case of any Query, please call : 080-26998xxx / 2674xxxx or fax no. 080-2674xxxx

 ಪುನಮ್ ಮಿಶ್ರಾ, ಹಿರಿಯ ವ್ಯವಸ್ಥಾಪಕರು/ಎಸ್.ಸಿ. & ಪಿ.ಎಂ.-ಎಂ.ಡಿ.
 ಪುನಮ್ ಮಿಶ್ರಾ, ಸಿ.ಐ. ಪರಿಷತ್/ಎಸ್.ಸಿ. & ಪಿ.ಎಂ.-ಇಂಜಿ.
 PUNAM MISHRA, SR. MANAGER/SC & PV-ENGG.
 BHEL-EDN, MYSORE ROAD, BANGALORE-560026.

CONTACTOR (SIGN & SEAL)

COPYRIGHT AND CONFIDENTIAL
THE INFORMATION ON THIS DOCUMENT IS THE PROPERTY OF BHARAT HEAVY ELECTRICALS LTD. IT MUST NOT BE USED DIRECTLY OR INDIRECTLY IN ANY WAY DETRIMENTAL TO THE INTEREST OF THE COMPANY.

SIGN. & DATE

REF. DRG. No.

INVENTORY No.

3 679 05 00849

DRG. No.

1640x992(Please see above for other 2 types of modules—Total 3 types of PV Modules).

- NOTE:
- UNLESS OTHERWISE SPECIFIED ALL DIMENSIONS ARE IN MM.
 - ALL MEMBERS ARE GALVANIZED . ALL FASTENERS ARE SS316.
 - GALVANIZATION SHALL BE DONE AFTER FABRICATION INCLUDING CUTTING & PUNCHING OF HOLES.
 - REMOVE ALL SHARP AND BURR EDGES.
 - GENERAL TOLERANCE FOR CLASS 'M' IN ACCORDANCE WITH ISO:2768.
 - GALVANIZING – IS:2629, IS:4759 & IS:4756 BUT MINIMUM 80 MICRONS (MASS OF COATING TO BE MIN 610 gsm).
 - IS:811 COLD FORMED LIGHT GAUGE STRUCTURAL STEEL SECTION.
 - IS:2062 FOR HOT ROLLED SECTIONS.
 - THE PV MODULE DIMENSIONS AND FIXING HOLES TO BE FINALIZED DURING PROTOTYPE.
 - PURLIN LENGTH IS SUBJECT TO CHANGE WITH PV MODULE DIMENSION.
 - PROTOTYPE TO BE DONE WITH ALL MMS ,FASTENERS AND PV MODULE FRAME.

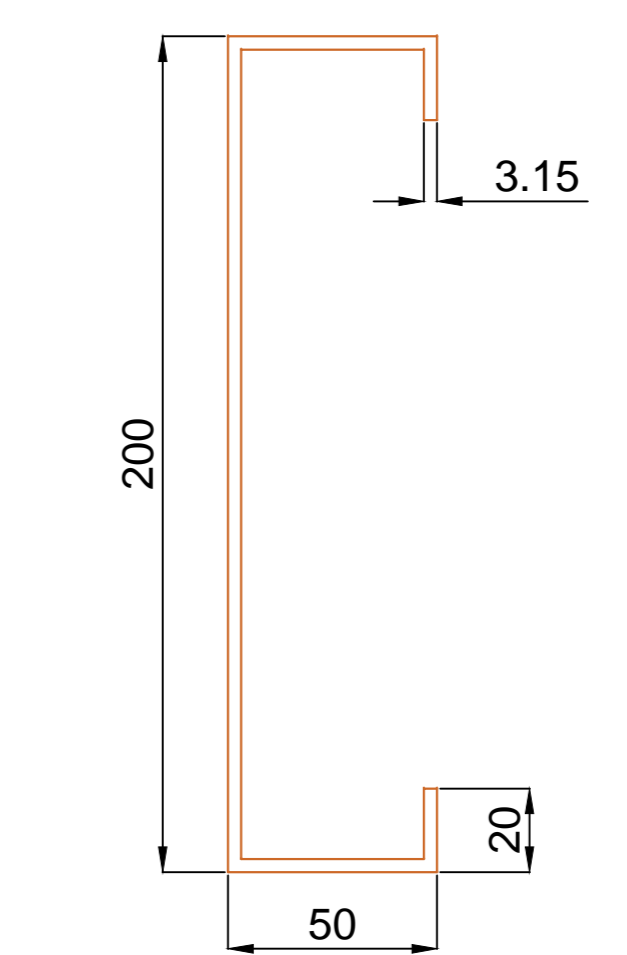
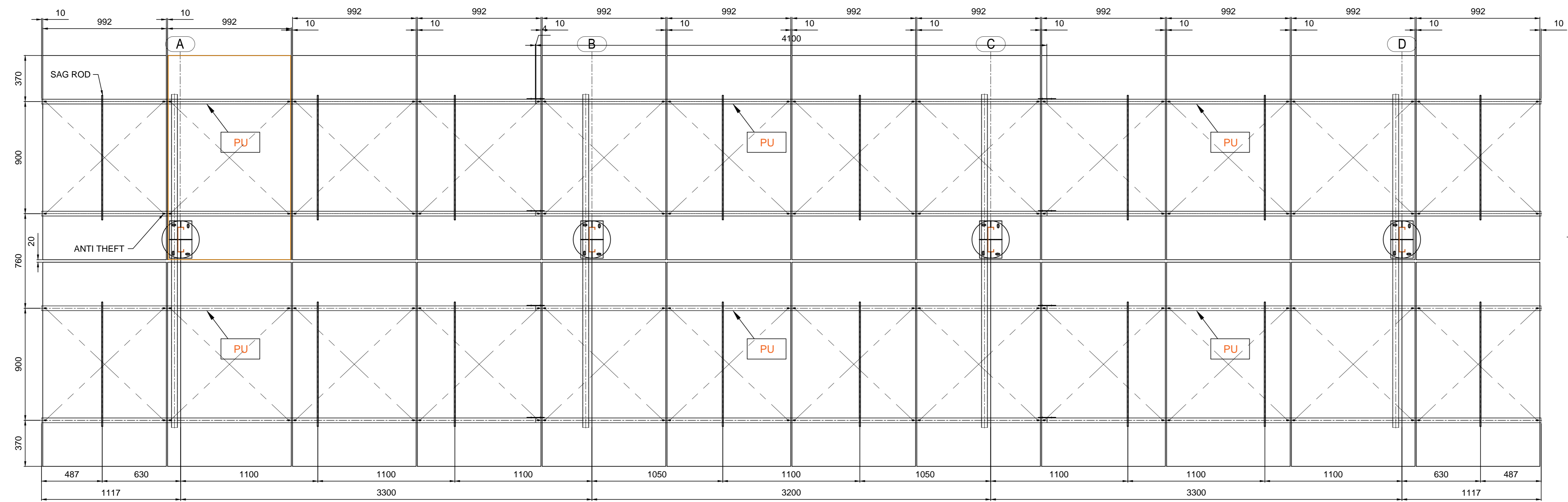
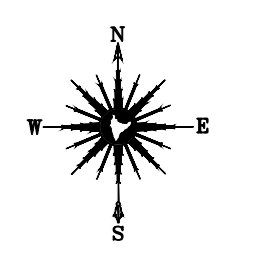

CL1
COLUMN
(CS200x50x3.15x20)

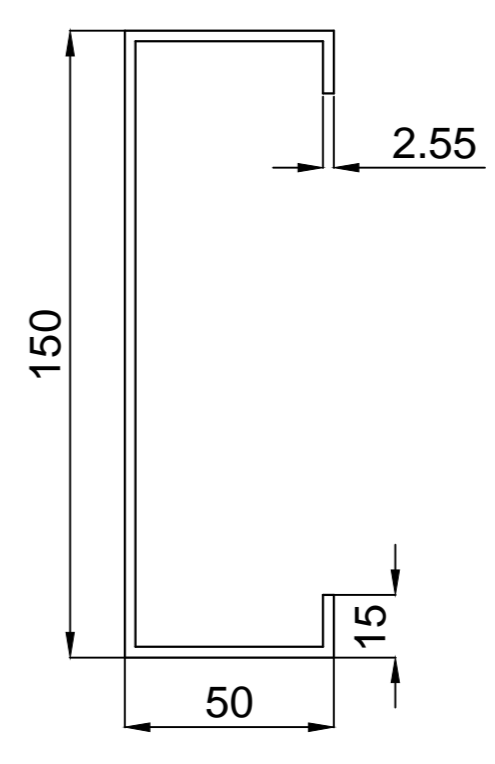

RF1
RAFTER
(CS150x50x2.5x15)

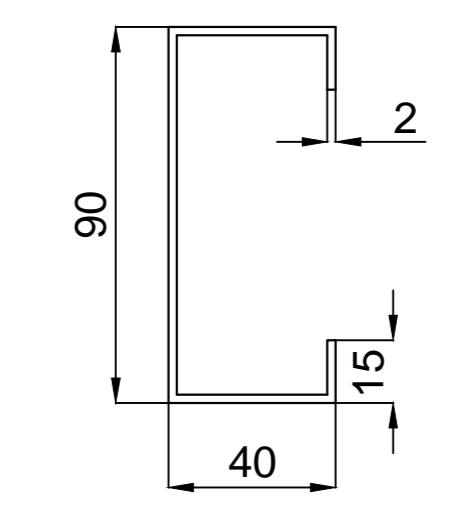

PU1
PURLIN
(CS90x40x2x15)

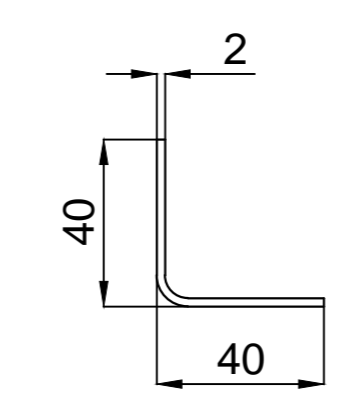

BR
BRACING
(LU40x40x2)

TABLE FOR DIMENSIONAL TOLERANCE:

NO.	DESCRIPTION	TOLERANCE
1	Overall Dimensions	±0.5
2	Dimensional Accuracy	±0.3
3	Perpendicularity	±0.1
4	Parallelism	±0.1
5	Surface Finish	12.5
6	Dimensional Accuracy	±0.3
7	Dimensional Accuracy	±0.3
8	Dimensional Accuracy	±0.3
9	Dimensional Accuracy	±0.3
10	Dimensional Accuracy	±0.3
11	Dimensional Accuracy	±0.3
12	Dimensional Accuracy	±0.3
13	Dimensional Accuracy	±0.3
14	Dimensional Accuracy	±0.3
15	Dimensional Accuracy	±0.3
16	Dimensional Accuracy	±0.3
17	Dimensional Accuracy	±0.3
18	Dimensional Accuracy	±0.3
19	Dimensional Accuracy	±0.3
20	Dimensional Accuracy	±0.3

GENERAL NOTES

- ALL DIMENSIONS ARE IN MILLIMETERS UNLESS OTHERWISE SPECIFIED
- DO NOT SCALE THE DRG. ONLY WRITTEN DIMENSIONS SHALL BE FOLLOWED.

FOLLOWING CODES HAVE BEEN USED FOR DESIGN

- IS 875:1987- CODE OF PRACTICE FOR DESIGN LOAD (OTHER THAN EARTHQUAKE)
- IS 801:1975- CODE OF PRACTICE FOR USE OF COLD-FORMED LIGHT GAUGE STEEL STRUCTURE
- IS 800:1984- CODE OF PRACTICE FOR USE OF HOT-ROLLED STEEL STRUCTURE

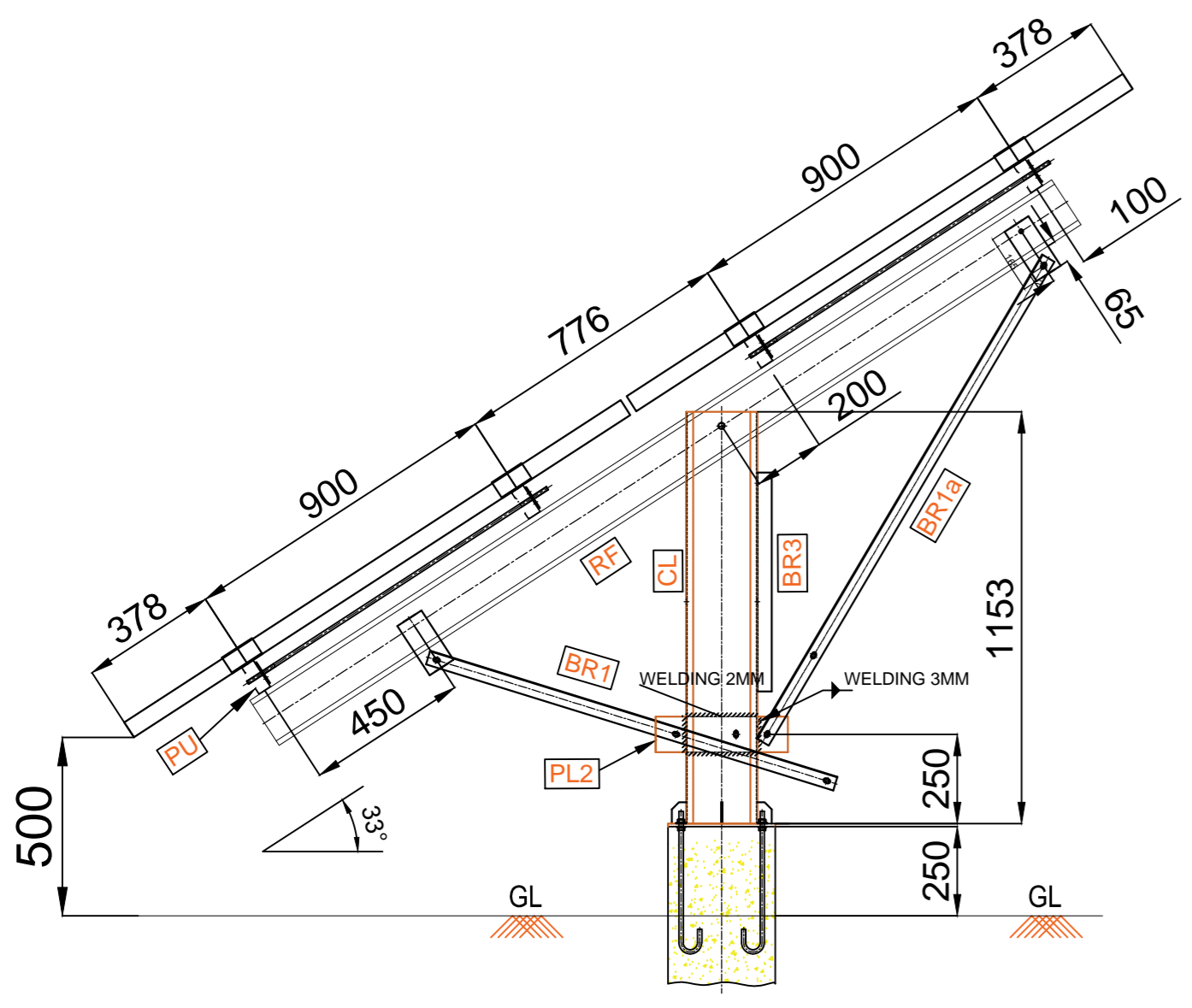

SIDE VIEW MADE BY LOOKING FROM *

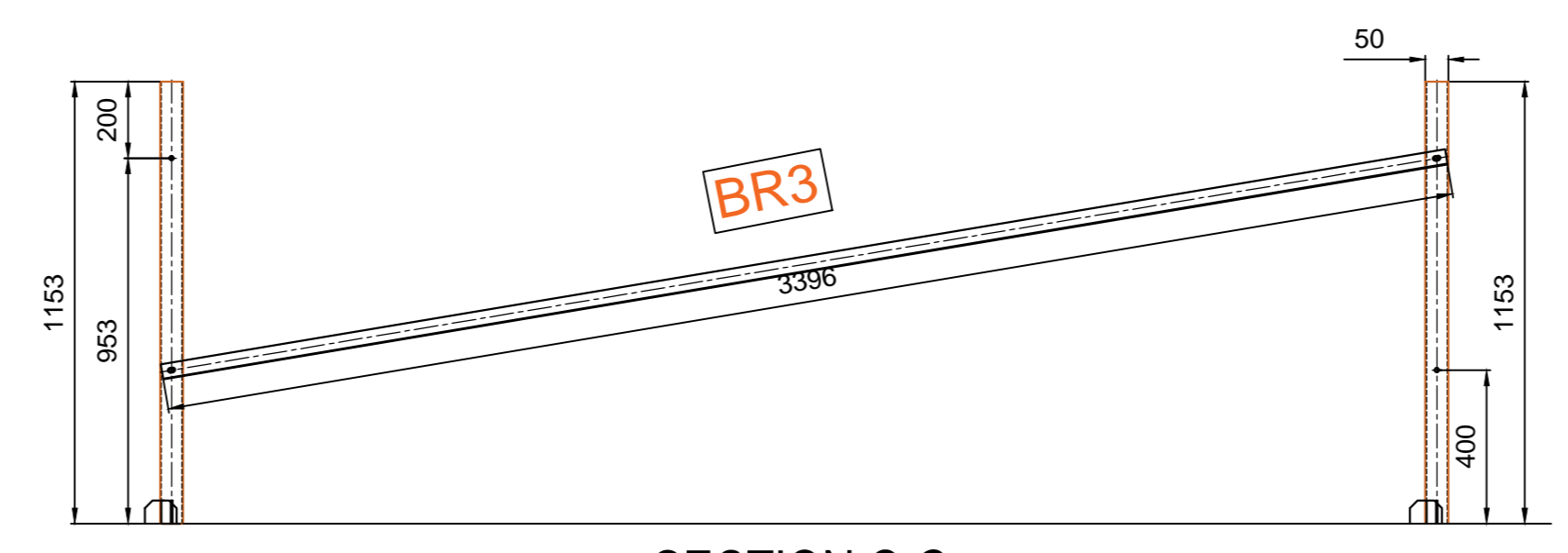
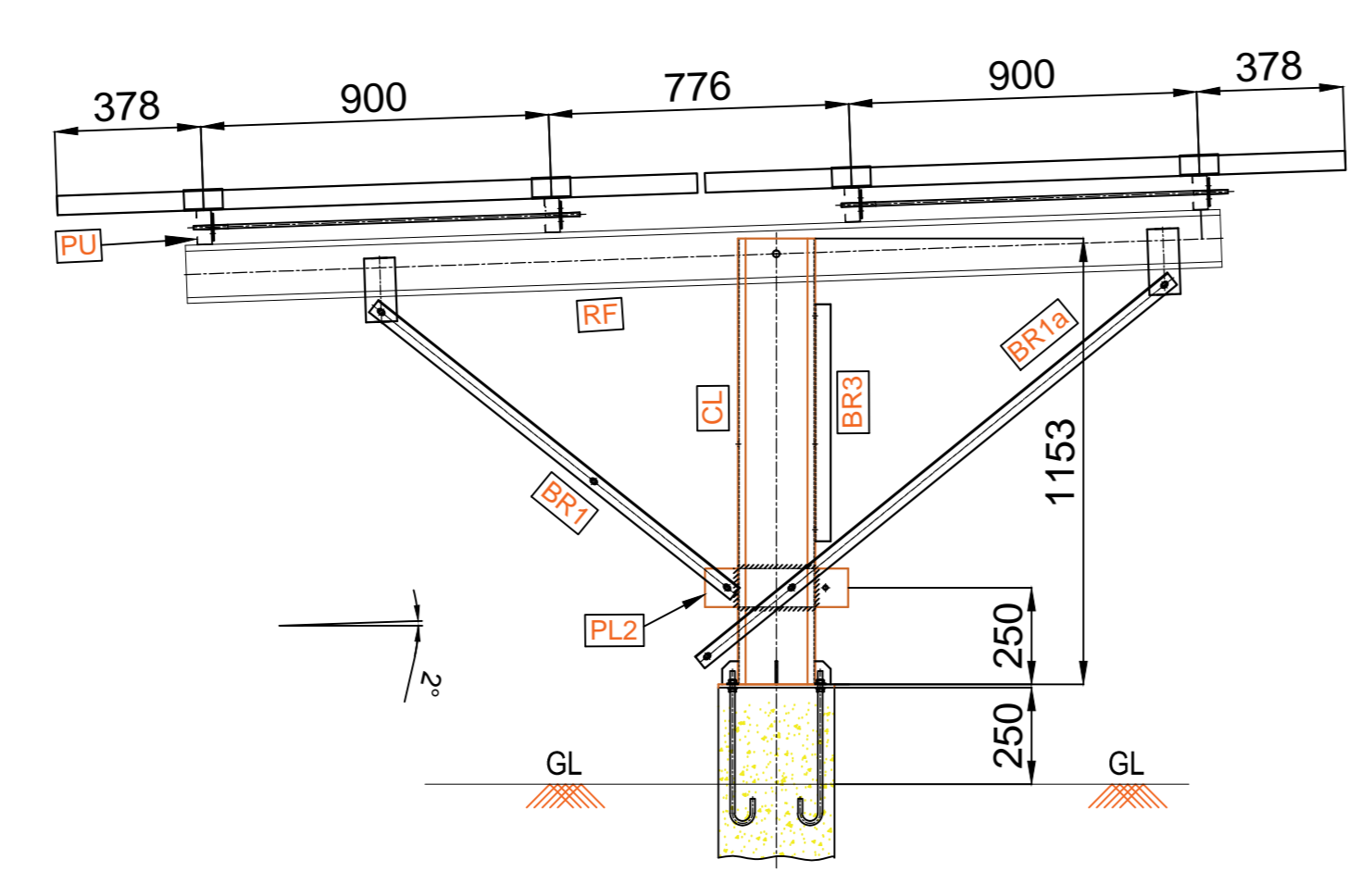

SECTION C-C

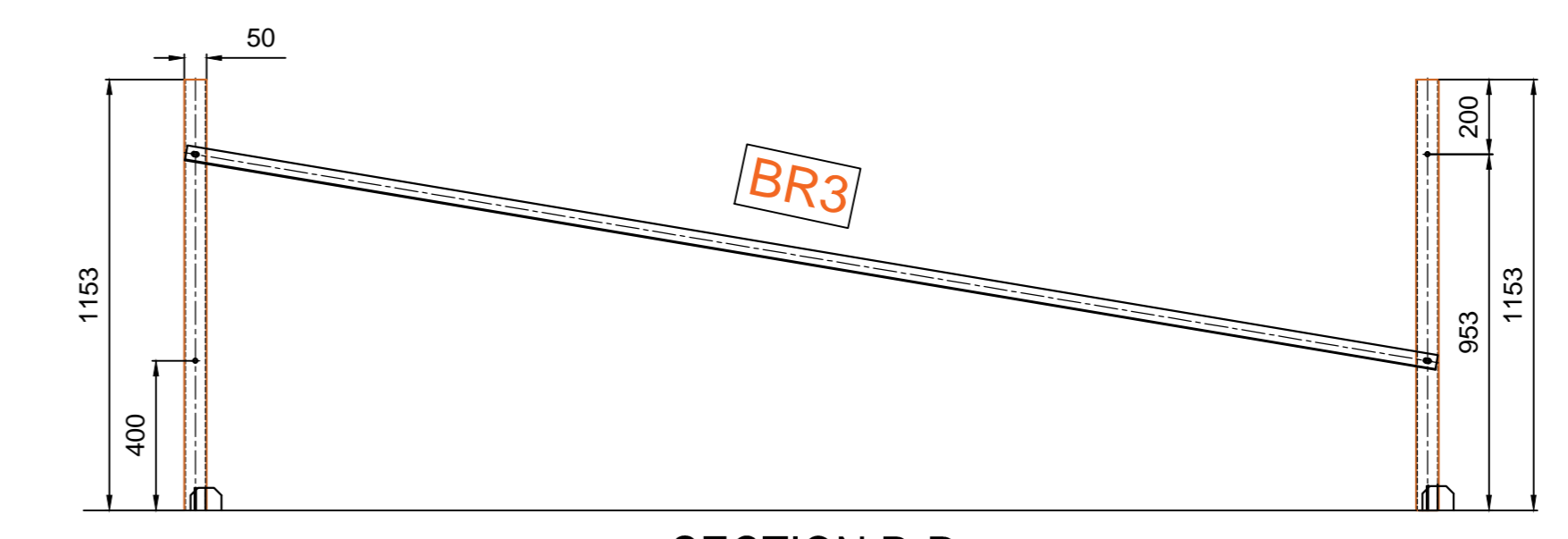

SECTION D-D

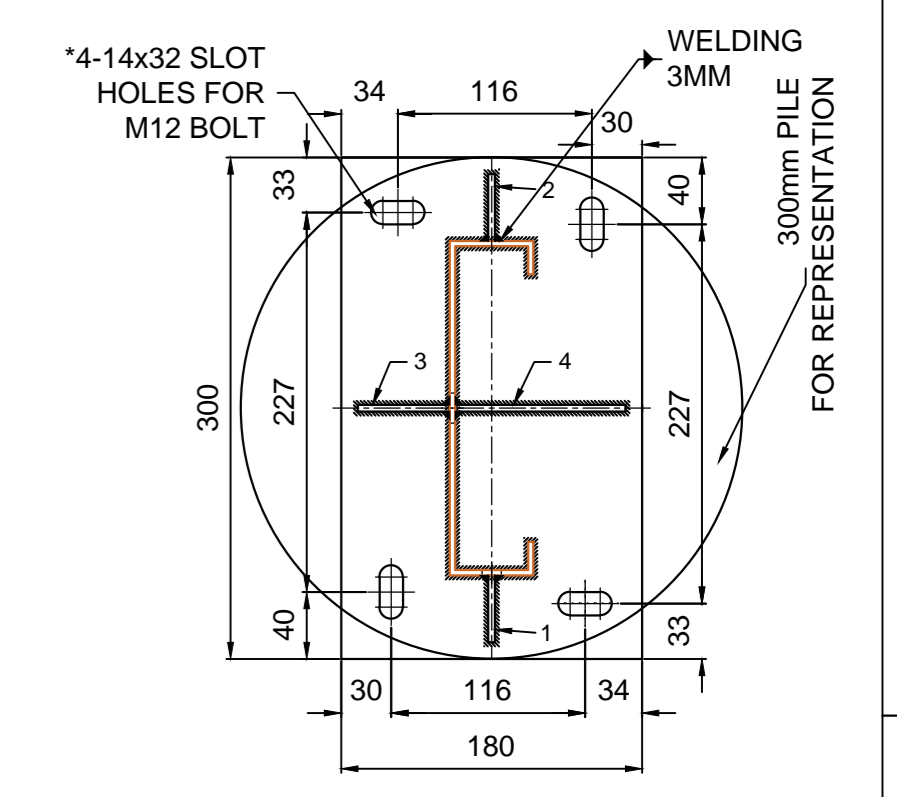

ANCHOR BOLT SCHEDULE

BOLT DESCRIPTION	QTY	M	N	R	T
AB 12x400	12	400	36	20	62

*BASE PLATE HOLE IS MADE IN DUE DILIGENCE FOR ALIGNMENT AT SITE. HOWEVER FOR EACH BOLT TWO NUTS ARE PROVIDED AND ID AND OD OF WASHER ARE 14MM AND 24 MM AS PER IS CODE & THIS WILL BE ENSURED IN THE SUPPLIES.

PROJECT : 15MW SOLAR POWER PLANT
CUSTOMER : BEL

BHARAT HEAVY ELECTRICALS LIMITED.
ELECTRONICS DIVISION, BANGALORE

TITLE: **GA OF MOUDLE MOUNTING STRUCTURE**

No. OF SHEETS	01
SHEET No.	01
REV	03

BEL DRG. No. **3 679 05 00849**
SECI-SD-BEL4-DBR-CIV-020

REV.	DATE	ALTERED	SAN	REV.	DATE	ALTERED	NAME	SIGN	DATE
02	04/08/16	CHECKED	PM	01	02/08/16	APPROVED	SAN	[Signature]	020816
03	05/08/16	APPROVED	MS						
02		COMMENTS OF SECI INCORPORATED							
03		TOLERANCE TABLE ADDED.							

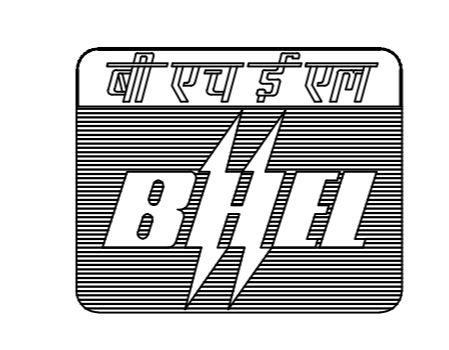

DEPT. SC&PV
CODE 439

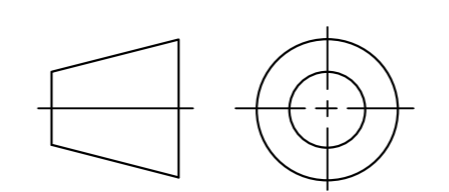



**Section 6:
Price Bid**

1	BHEL estimate	BHEL estimates of year-wise rates and amounts, along with the total estimated value, are indicated in the shaded columns of table of Bill of Quantities below.
2	Price quote by bidder	Bidder shall fill the rates and amounts in the respective spaces. Rates shall be entered in both figures and words. In case of discrepancy between figure and word, lowest of the two will be considered and, accordingly, total amounts will be taken.
3	Reverse auction	BHEL reserves right to conduct reverse auction. Bidders are advised to quote their best prices because no further price bids will be accepted in case BHEL decides to open price bids instead of reverse auction.
4	Evaluation by BHEL	For evaluation of L1 price, BHEL will take sum of the present values of the 10 cycles at annual discounting rate of 5% for comparison of prices. Accordingly, net present value (NPV) will be calculated as: $A1 + (A2+A3)/1.05 + (A4+A5)/1.05^2 + (A6+A7)/1.05^3 + (A8+A9)/1.05^4 + A10/1.05^5$, where A1, A2, ..., A10 will be the amounts quoted by the bidder for the 10 cycles.

S.No	Year of module tilting	Month of module tilting	Number of structures	Estimate by BHEL (Rs)		To be filled by Bidder (Rs)	
				Rate per structure excluding tax	Amount for total structures excluding tax	Rate per structure excluding tax	Amount for total structures excluding tax
			(X)	(Y)	(X) x (Y)	(Z)	A = (X) x (Z)
1	2017	Nov	2893	86	248798		A1 =
2	2018	Mar	2893	89.5	258923.5		A2 =
3	2018	Sep	2893	89.5	258923.5		A3 =
4	2019	Mar	2893	94	271942		A4 =
5	2019	Sep	2893	94	271942		A5 =
6	2020	Mar	2893	98.5	284960.5		A6 =
7	2020	Sep	2893	98.5	284960.5		A7 =
8	2021	Mar	2893	104	300872		A8 =
9	2021	Sep	2893	104	300872		A9 =
10	2022	Mar	2893	109.5	316783.5		A10 =
				Total =	2798977.5	Total Rs =	

Total in words:

Taxes applicable:

Total including taxes in Figures: Rs

Total including taxes in words Rupees

 ಪುನಮ್ ಮಿಶ್ರಾ, ಹಿರಿಯ ವ್ಯವಸ್ಥಾಪಕರು/ಎಸ್.ಸಿ. & ಡಿ.ವಿ.-ಎಂಜಿ.
 पुनम मिश्रा, वरिष्ठ प्रबंधक/एस.सी. एवं पी.वी.-इंजी.
 PUNAM MISHRA, SR. MANAGER/SC & PV-ENGG.
 BHEL-EDN, MYSORE ROAD, BANGALORE-560026

CONTACTOR (SIGN & SEAL)