



Bharat Heavy Electricals Limited

(A Govt. of India Undertaking)

Power Plant Piping Unit, Thirumayam – 622 507, Tamil Nadu

Tender Notice

NOTICE INVITING e-TENDER

Dear Sir/ Ma'am,

Ref: Tender No. PPPU: WC: 22: 030 dt. 27.12.2022.

Subject: Two-part e-Tender inviting techno-commercial and price bids for “Civil AMC Works at PPPU, Thirumayam (Except Plumbing repair works but including new plumbing works) for a period of 18 months”

Kindly submit your competitive offer for the above subject work as per the tender terms and conditions given in the tender document through e-procurement portal <https://eprocurebhel.co.in/nicgep/app> only.

Scope of work	Civil AMC Works at PPPU, Thirumayam (Except Plumbing repair works but including new plumbing works) for a period of 18 months (Scope of work and technical terms & conditions as per Techno-Commercial Part-I bid.)
Location of work	BHEL PPPU Thirumayam -622507 (Tamilnadu)
Duration of Contract	18 Months
Date / Time of Pre Bid Meeting	10:00 Hrs on dt. 31.12.2022 via online. Link for meeting:- Microsoft Teams meeting Join on your computer, mobile app or room device Click here to join the meeting Meeting ID: 433 346 382 753 Passcode: uAf8XL
Last date/ time for receipt of tender	10:00 Hrs on dt. 06.01.2023
Commencement of work	On the date of commencement mentioned in the LOI
Date / Time & place for opening of Technical Bid	14:30 Hrs. on 06.01.2023 via On line through e-procurement by Contracts, PPPU, Thirumayam (In case of any change in opening date, if any, will be intimated later.)
Date/Time of Price Bid Opening	The date/ time of price bid opening will be intimated separately.
EMD AMOUNT	Rs. 30,000/- (Rupees Thirty Thousand Only)
Working Area Contact details	Manager/ Civil Maintenance & HSE Power Plant Piping Unit, BHEL -Thirumayam – 622507, Contact No. 04333-279392/ 9489202807 Email: gmarjun@bhel.in Vendors may visit the work area prior to submission of offer to understand the details of scope of work.

Place
Date

Signature of the Bidder
(NAME & ADDRESS WITH SEAL)



Bharat Heavy Electricals Limited

(A Govt. of India Undertaking)

Power Plant Piping Unit, Thirumayam – 622 507, Tamil Nadu

Tender Notice

INSTRUCTIONS

This two- part e- tender consists of the following:

Part – I (A): Pre-qualification Bid

1. Earnest Money Deposit (EMD)

Part – I (B): Techno-Commercial Bid

2. PQC criteria for the contract
3. Scope of work and Work specific terms & conditions
4. General terms & conditions of the contract
5. All Annexures.

Part – II: Price Bid

Special Instructions to the bidders:

1. EMD should be submitted as per Part-I(A)/Prequalification Bid/EMD (including EMD waiver, if any). Techno-commercial bid will be considered only if the Part-I(A)/Prequalification Bid/EMD is valid. EMD in any other form and tender without EMD will be summarily rejected.
2. In case of offline payments, the hardcopies of Earnest Money Deposit (EMD) document/ DD submitted to BHEL PPPU Thirumayam and the soft-copies uploaded at the time of online bid submission should be the same, otherwise the tender will be summarily rejected.
3. Bidder should arrange for the EMD as specified in the tender. The original should be posted/couriered/given in person in a sealed cover super scribing 'Tender number/date/PartI(A)/EMD' to the Tender Inviting Authority, within the bid submission date and time for the tender.
4. Any deviation to this tender terms & conditions, and schedules of this tender will lead to total rejection of the offer submitted.
5. Tenderer who have been suspended or black listed or issued with "Show Cause Notice" by BHEL, Tiruchirappalli -620014 or any other unit or GOI will not be allowed to participate in the tender, and bidder should declare the same in the tender. Even during the course of evaluation/ finalization of tender if it is found that some of the parties are black listed/ barred from business transaction/ under business hold, BHEL will not consider them for further participation in the tender. Bid of Tenderers who has been issued Contractual letter / Notice of termination / Termination letter by BHEL will not be considered for bid evaluation.
6. Should a tenderer find discrepancies or omissions in the tender documents, or should there be any doubt as to their meaning, he should at once address the authority inviting the tender, for clarification well before the due date, so as to submit his tender in time. No extension of time shall be given for submission of the tender on any account.
7. Rates should be quoted as per the Work / Rate schedule (Price bid/Part –II). Rates quoted in any other form will not be accepted, and will be rejected.
8. The tender documents must be signed physically / digitally by Director / Partner of the Firm or by the person holding the Power of Attorney on behalf of the Firm concerned. In the latter case, a copy of Power of Attorney, duly attested by a Notary Public must accompany the tender.
9. If a tenderer deliberately gives wrong information in his tender or creates conditions favourable for the acceptance of his tender, the BHEL will reject such tender at any stage.
10. Words imparting singular number shall be deemed to include plural number and vice-versa where the context so requires.

Place
Date

Signature of the Bidder
(NAME & ADDRESS WITH SEAL)



Bharat Heavy Electricals Limited

(A Govt. of India Undertaking)

Power Plant Piping Unit, Thirumayam – 622 507, Tamil Nadu

Tender Notice

11. Should a Tenderer's or a Contractor's or in the case of a firm or company of contractors/any of its shareholder's or shareholder's relative is employed in BHEL, the authority inviting the tenders shall be informed in writing of this fact at the time of submission of the tender, failing which the tender may be disqualified, or if such fact subsequently comes to light, the contract may be cancelled.
12. The tender schedule, and the tender shall be deemed to form an integral part of the contract to be entered into for this work.
13. Tender can be cancelled at any stage due to unavoidable circumstances.
14. Kindly ensure that the total size of the scanned documents to be uploaded remains minimum. If required, documents may be scanned at lower resolutions say at 150 dpi. However, it shall be sole responsibility of bidder that the uploaded documents remain legible.
15. Bidder is advised not to wait till the last minutes or last few seconds w.r.t tender closing time to submit their offer to avoid complications related with internet connectivity / network problem/ power failure etc.
16. Bidder is advised take due care while quoting the technical and price bids forms in the e-procurement system. Bidder, who tampers with tendering procedure affecting ordering process or misusing the technical information of the tender document or withdrawing their offer after price bid opening, will be penalized as per BHEL guidelines on suspension of business dealings with suppliers/ contractors. Abridged version of the guideline is available in www.bhel.com.
17. It is advised that all the documents to be submitted are kept scanned or converted to PDF format in a separate folder on your computer before starting online submission.
18. The bidder has to upload the scanned copy of all the mentioned original documents (in colour) during online bid-submission.
19. In case you are not in a position to submit the offer, please send letter suitably specifying the reasons thereof.
20. The evaluation currency for this tender shall be INR.

Thanking you,
For **Bharat Heavy Electricals Limited**

Jayaram C B
DGM (Contracts/ MS / DTG) Power
Plant Piping Unit
BHEL -Thirumayam – 622507
Contact No. 04333-279551, 9442230731
cbjayaram@bhel.in

Place
Date

Signature of the Bidder
(NAME & ADDRESS WITH SEAL)



Bharat Heavy Electricals Limited

(A Govt. of India Undertaking)

Power Plant Piping Unit, Thirumayam – 622 507, Tamil Nadu

Tender Notice

PART – I (A)

EMD

1 EARNEST MONEY DEPOSIT (EMD)

1.1 **EMD AMOUNT:** Refer page 1 of this tender document.

1.1.1 EMD shall not carry any interest.

1.1.2 EMD will be retained as part of Security Deposit.

1.2 EMD WAIVER DOCUMENTS for MSE (Micro & Small Enterprises only) vendor.

1.2 EMD WAIVER DOCUMENTS for MSE (Micro & Small Enterprises only) vendor

1.2.1 Valid UDYAM registration certificate as on date of technical bid opening shall be self-attested.

Note: - EMD is waived off for Joint Venture companies of BHEL, State or Central PSUs / Government departments / Autonomous / Educational / Research Institutes.

1.3 MODES OF DEPOSIT OF EMD AMOUNT:

The EMD may be accepted only in the following forms:

1.3.1 Electronic Fund Transfer credited in BHEL account (before tender opening) - Online Payment procedure for EMD and SD amount attached (Annexure – I (page.no.40)) for vendors' reference.

1.3.2 Demand draft, in favour of **BHEL, Trichy-14** payable at **Trichy** (along with offer).

1.3.3 In addition to above, the EMD amount in excess of ₹2 lakhs (TWO LAKHS) will also be accepted in form of Bank Guarantee from scheduled bank, provided the Bank Guarantee is valid for at least six months from the due date of tender submission. For instance, if EMD amount is ₹2,50,000/ - , BG can be submitted for ₹50,000/ - and rest ₹2,00,000/ - to be submitted through other modes mentioned above.

1.4 FORFEITURE OF EMD:

EMD by the tenderer will be forfeited as per tender documents if:

1.4.1 After opening the tender and within the offer validity period, the tenderer revokes his tender or makes any modification in his tender which is not acceptable to BHEL.

1.4.2 The Contractor fails to deposit the required Security deposit or commence the work within 15 days of LOI/ WO/ Contract.

1.4.3 EMD by the tenderer shall be withheld in case any action on the tenderer is envisaged under the provisions of extant "Guidelines on Suspension of business dealings with suppliers/ contractors" and forfeited/ released based on the action as determined under these guidelines. Abridged version of the guideline is available in www.bhel.com.

Place
Date

Signature of the Bidder
(NAME & ADDRESS WITH SEAL)



Bharat Heavy Electricals Limited

(A Govt. of India Undertaking)

Power Plant Piping Unit, Thirumayam – 622 507, Tamil Nadu

Tender Notice

PART – I (B)

TECHNO-COMMERCIAL BID

PRE QUALIFICATION CRITERIA FOR THE CONTRACT

Sl. NO	CATEGORY	DETAILS
1.	STATUS OF THE COMPANY 1. Proprietorship: PAN card on owner name 2. For partnership firms: PAN card and PARTNERSHIP DEED 3. For others: PAN card in the name of company / firm / business and CERTIFICATE OF INCORPORATION / MOA (Memorandum of Association and AOA (Articles of association)).	Copy to be uploaded in EPS portal
2.	Goods & Service Tax (GST) registration / Application Reference Number. [(copy of registration details indicating GSTIN/ARN to be submitted along with offer. (If any specific exemption is available, a declaration with due supporting documents need to be furnished for considering the offer).]	Copy to be uploaded in EPS portal
3.	The bidder should furnish details of successfully executing similar works in the last 7 years as on the date of tender opening as follows: a. At least Three similar works each not less than Rs. 6 Lakhs or b. Two similar works each not less than Rs.7.50 Lakhs or c. At least One similar work not less than Rs.12.0 Lakhs. Similar Work means "Any kinds of Civil Construction/ Maintenance works including excavation, masonry, RCC works, plumbing, carpentry, steel, glazing, roads etc.," Proof of Work Order / Purchase Order/ Experience certificate should be attached. Proof of experience from any organization other than BHEL Trichy / Thirumayam to be supported by TDS (Tax Deducted at Source) certificate issued by the organizations OR Form 26 AS or bank statement for transaction of payment.	Proof to be uploaded in EPS
4.	Duly signed certificate of compliance in bidder's letter head shall be attached.(Annexure III)	Duly signed and stamped to be uploaded in EPS portal
5.	Duly signed Local content Declaration in bidder's letter head shall be attached (Annexure II)	Duly signed and stamped to be uploaded

Note:

- At any stage, BHEL may ask for original documents and contractor has to submit the same.
- All the documents should be valid & to be renewed and kept valid throughout the contract period, if contract is awarded.
- Apart from furnishing the above details, copies of relevant documents/ certificates must be uploaded with the Technical Bid.
- If at any stage, the document(s) submitted by contractor is/are found incorrect/ false/ manipulated, the necessary action will be taken by BHEL against contractor as per the "Guidelines for suspension of Business dealings".

Place
Date

Signature of the Bidder
(NAME & ADDRESS WITH SEAL)



Bharat Heavy Electricals Limited

(A Govt. of India Undertaking)

Power Plant Piping Unit, Thirumayam – 622 507, Tamil Nadu

Tender Notice

I. SCOPE OF WORK:

Since this contract is of Maintenance contract in nature, the works will be given as sub work orders with separate delivery due dates for each sub work order. The contractor should undertake to execute any of the items listed in the attached BHEL Schedule of Rates - SR 13-14 at the quoted percentage without any reservation to any of the items in the SR.

A copy of BHEL SR 13-14 with description of work, Unit of Measurement and the SR Rate, duly signed and sealed should be attached with the tender document. Plumbing repair works for example: attending to water leakages, blockages etc., will NOT be covered under this contract. New Plumbing works for example: replacement of broken ceramic ware (Wash basins, urinals, laying of new pipelines etc.,) is INCLUDED in this contract. All tools, plants, machinery, manpower, PPEs, sand/ M-Sand, aggregates, vendor supply items as per BHEL SR 13-14 etc., are under contractor's scope.

Apart from this, BHEL General Conditions of Contract and Special Conditions of Contract (Given separately), duly signed and sealed should also be attached in the tender document.

Note: Duly signed BHEL Schedule of Rates - SR 13-14 to be attached with Price bid of tender document.

The following table lists the tentative percentage of the value of work that may be executed against each chapter of BHEL-SR 13-14.

SR Chapter No	Chapter Name of BHEL SR 2013-14	Tentative Work % of tender value
I.	EARTHWORK	30%
II.	CONCRETE WORKS	
III.	MASONRY WORKS	
IV.	WOOD WORKS	20%
V.	STEEL WORKS	
VI.	FLOORING	
VII.	ROOFING	
VIII.	FINISHING	

Place
Date

Signature of the Bidder
(NAME & ADDRESS WITH SEAL)



Bharat Heavy Electricals Limited
(A Govt. of India Undertaking)
Power Plant Piping Unit, Thirumayam – 622 507, Tamil Nadu

Tender Notice

IX.	ROAD WORKS	10%
X.	DISMANTLING AND DEMOLITION	
XI.	WATER SUPPLY AND SANITARY ITEMS	
XII.	ALUMINIUM WORKS AND FALSE CEILING ETC.,	40%
XIII.	PILE WORKS	
XIV.	HORTICULTURE	
XV.	MISCELLANEOUS	

Important Note: The above split up percentage is only tentative and for information purpose only. It is to be noted that these percentages may vary by a wide margin during actual execution based on the user department requirement and type of work undertaken. The very nature of Civil AMC is the unpredictability of the items that will be operated. The contractor/ bidder is supposed to execute the ordered quantity on any of the items of the BHEL Schedule of Rates without any reservation.

BHEL SCOPE OF SUPPLY:

The required power, compressed air, water, cement, reinforcement steel, structural steel, SSTP tubes will be given by BHEL free of cost.

BILL OF QUANTITY

SL NO	DESCRIPTION OF WORK	VALUE OF THE CONTRACT Rs.
1.	All Items of BHEL SR 2013-14 except those that are plumbing maintenance in nature, but includes entirely new plumbing and sanitary ceramic fittings like Urinals, WCs, Wash basins etc.,	15,00,000/- (Rupees Fifteen Lakhs Only)

Place
Date

Signature of the Bidder
(NAME & ADDRESS WITH SEAL)



Bharat Heavy Electricals Limited

(A Govt. of India Undertaking)

Power Plant Piping Unit, Thirumayam – 622 507, Tamil Nadu

Tender Notice

II. COMMERCIAL TERMS & CONDITIONS:

01. TERMS FOR PRICE BID & RATE BASIS

- i. Price bid is to be submitted in a separate price bid form provided in the portal.
- ii. The rates quoted should be **Exclusive of GST (but inclusive of any other taxes & duties)** levied or to be levied both by Central and State Government Authorities. Such levies, if any, should be borne only by the Contractor.)
- iii. The applicable rate of GST in % should be mentioned in the Technical bid forms in EPS.
- iv. GST Payment will be reimbursed as per statutory provisions, subject to production of proof of payment / remittances only.
- v. The rates quoted in the tender shall remain **valid** initially for a period of at least **120 days** from the date of opening of Tender. After successful award of contract, the rates shall be firm throughout the contract period.
- vi. ***Contractor has to ensure that all statutory payment as per Minimum wages act, 1948/ Payment of Wages act etc. is taken care of while quoting. No claim in respect to payment to workman will be entertained at a later stage. It will be responsibility of contractor to comply with statutory payments to workmen in this regard.***
- vii. ***Before tendering, the tenderers are strongly advised to inspect the site of work and its environments and be well acquainted with the actual working and other relevant conditions, position of materials and labour under scope of work covered.***
- viii. BHEL reserves the right to
 - Cancel the tender at any stage.
 - Negotiate or re-float the tender opened if L1 price is not the lowest acceptable price to BHEL inter alia other reasons.
- ix. All payments from BHEL in view of the execution of the contract are liable for IT (TDS), GST (TDS), PF & Group Insurance and all other statutory provisions as applicable. Hence, bidders shall confirm that they have suitable mechanism for effective compliance to the same.

02. PROVISION FOR MSE (MICRO & SMALL ENTERPRISES) SUPPLIERS:

MSE suppliers can avail the intended benefits only if they submit along with the offer, self-attested copies of UDYAM Registration Certificate.

2.1 Definitions of MSEs owned by Women is under:

- i. In case of proprietorship firm, proprietor must be woman.
- ii. In case of partnership firm, the women partners must be holding at least 51% shares in the unit.
- iii. In case of private limited companies, at least 51% share must be held by women promoters.

2.2 Definitions of MSEs owned by SC/ST is under:

- In case of proprietorship firm, proprietor must be SC/ST.
- In case of partnership firm, the SC/ST partners must be holding at least 51% shares in the unit.
- In case of private limited companies, at least 51% share must be held by SC/ST promoters.

Place
Date

Signature of the Bidder
(NAME & ADDRESS WITH SEAL)



Bharat Heavy Electricals Limited

(A Govt. of India Undertaking)

Power Plant Piping Unit, Thirumayam – 622 507, Tamil Nadu

Tender Notice

- Authorized Offices to Issue SC/ST certificate. The caste/Tribe/Community certificate issued by the following authorities in the prescribed form for SCs/STs can be considered.
- District Magistrate / Additional District Magistrate / Collector / Deputy commissioner / Additional Deputy commissioner / Deputy collector/ 1st class stipendiary magistrate/ Sub divisional Magistrate/ Taluka Magistrate/ Executive magistrate/ Extra Assistant commissioner.
- Chief Presidency magistrate/ Additional chief presidency magistrate/ Presidency magistrate.
- Revenue Officer not below the rank of tahsildar.
- Sub-Divisional officer of the area where the individual and/ or his family normally resides.
- To avail the benefits of MSE under SC/ST category, the related documents as stated above should be submitted along with tender documents.

2.3 If MSEs quoted price is within price band L-1 + 15%, when L1 is non- MSE, the MSEs will be allowed to supply at least 25% of tendered quantity at L-1 rate subject to acceptance by MSEs to L-1 rate. (Minimum of 3% reservation for women owned MSEs and 6.25% for MSEs owned by SC/ST within the above mentioned 25% reservation). In case the contract cannot be split, the full/ complete supply of total tendered value shall be awarded to MSE. The preference to the MSEs will be given in order of their ranking L1, L2, L3, etc.

2.4 Start-up companies will be provided benefits and relaxation as per the latest government norms. For availing start-up benefits, relevant certificates issued by Department of Industrial Policy and Promotion shall be submitted along with the tender.

03. TAXES AND DUTIES:

1. GST portion of invoice will be released only upon:
 - 1.1 Vendor declaring such invoice in his GSTR-1 and
 - 1.2 Receipt of goods and tax invoice by BHEL and
 - 1.3 Confirmation of payment of GST thereon by vendor on GSTN portal
2. In case GST credit is delayed or denied to BHEL due to non /delayed receipt of goods/services and /or tax invoice or expiry of timeline prescribed in GST law for availing such ITC or any other reasons not attributable to BHEL, GST amount will be recovered from vendor along with interest levied or leviable on BHEL from payment due to vendors (bills, SD etc.) from BHEL.
3. In case vendor delays declaring such invoice in his return and GST credit availed by BHEL is denied or reversed subsequently as per GST law, GST amount paid by BHEL towards such ITC reversal as per GST law will be recovered from vendor /contractor along with interest levied/leviable on BHEL from payment due to vendors such as running bills or Security deposit etc. from BHEL.

Note:

1) Three copies of GST rule compliant tax INVOICE with original signature to be submitted every month on completion of work.

2) GST will be charged on the EMD/SD amount forfeited (in-case) from the bidder at the applicable rates. GST tax Invoice will be issued to the vendor on receipt/recovery of GST amount from the vendor.

Place
Date

Signature of the Bidder
(NAME & ADDRESS WITH SEAL)



Bharat Heavy Electricals Limited

(A Govt. of India Undertaking)

Power Plant Piping Unit, Thirumayam – 622 507, Tamil Nadu

Tender Notice

04. CONTRACT PERIOD: -

- The period of contract shall be **18 Months** from commencement of work as indicated in LOI.
- If required, BHEL reserves the right to extend this subject contract for a further period under same terms and conditions subject to mutual acceptance of both parties.
- The contract may be terminated by BHEL due to violations or non-performance of the Contract conditions by giving one-month notice.

05. PAYMENT TERMS:

On Submission of error free invoices, certified by User department, along with Joint Measurement records, Logs, duly signed eMBooks and necessary welfare clearances the bills will be processed and payment will be made by BHEL after number of days mentioned below (depending on type of bidder) through NEFT/ RTGS to the contractor. Necessary GST Returns have to be filed in due time for claiming of payment of invoice.

Type of bidder	Payment terms(Number of days)
Micro & Small Enterprises (MSEs)	45 days
Medium Enterprises	60 days
Non MSME	90 days

06. PENALTY CLAUSE:

As per Clause 41 of "Compensation for Delay" under BHEL General Conditions of Contract which is given as a separate annexure and to be attached with the tender document.

COMPENSATION FOR DELAY:

If the contractor fails to maintain the required progress in time as per individual sub work orders or to complete the work and clear the site on or before the contracted or extended period of completion, he shall, without prejudice to any other right or remedy of the BHEL on account of such breach, pay as agreed compensation an amount calculated as stipulated below or such smaller amount as may be fixed by the BHEL on the contract value of the work for every week that the progress remains in time as per the individual sub work orders or that the work remains incomplete.

This will also apply to items or group of items for which separate period of completion has been specified.

For this purpose, the term 'Contract Value' shall be the value at contract rates of the work as ordered.

- Completion period (as originally-stipulated) -- at 1 percent per week not exceeding 6 months.
- Completion period (as originally-stipulated) -- at ½ percent per week exceeding 6 months.

Place
Date

Signature of the Bidder
(NAME & ADDRESS WITH SEAL)



Bharat Heavy Electricals Limited

(A Govt. of India Undertaking)

Power Plant Piping Unit, Thirumayam – 622 507, Tamil Nadu

Tender Notice

Provided always that the total amount of compensation for delay to be paid under this condition shall not exceed the under noted percentage of the contract value or of the contract value of the item or group of items of work for which a separate period of completion is given:

- a. Completion period (as originally-stipulated) -- 10 percent.
not exceeding 6 months.
- b. Completion period (as originally-stipulated) -- 7½ percent.
exceeding 6 months.

The amount of compensation may be adjusted or set-off against any sum payable to the Contractor under this or any other contract with the BHEL.

07. RISK PURCHASE:

1. In the event of any successful Tenderer's failure to fulfil any of the Tender / Contract Terms & Conditions / Obligations, explicitly expressed or implied, as per Tender / Contract, BHEL may entrust the job to alternate vendor and get it completed to meet the BHEL service requirements and additional expenditure if any including consequential cost shall be totally recovered from the contractor who failed to complete the job in line with the BHEL tender / contract.
2. The decision of BHEL with regard to the actual losses / consequential expenditure incurred by BHEL shall be final and binding on the contractor *and also 5% overhead charges to be added in addition to extra expenditure to BHEL.*
3. GST as applicable shall also be recovered.



Bharat Heavy Electricals Limited

(A Govt. of India Undertaking)

Power Plant Piping Unit, Thirumayam – 622 507, Tamil Nadu

Tender Notice

III. GENERAL:

1. The contractor agrees to indemnify BHEL against all claims and losses arising as a liability under the Payment of Wages Act, Employees Provident Fund & Miscellaneous Provisions Act, Industrial Disputes Act, Employees State Insurance Act, Contract Labour (Regulation & Abolition) Act, Workmen's Compensation Act, Arbitration Act, Minimum Wages Act, Inter State Migration Act etc. or any civil or criminal law in force so far as they relate to security personnel employed by the contractor for the company.
2. The liability of any compensation for injury to their staff or others arising as a result of duties by the staff shall be that of the contractor.
3. Income Tax, GST TDS or any other statutory dues liable to be paid by the contractor shall be recovered from the bills of the contractor for which TDS certificate will be issued by BHEL.
4. With regard to the interpretation of the terms and conditions of this contract, the decision of the Head of the Unit / BHEL – PPPU Thirumayam shall be final.
5. Disputes or differences arising from this tender or in any manner connected therewith shall be subjected to the following disputes resolution mechanism:
 - i. Any dispute shall initially be referred to the designated Senior Management of the parties for amicable settlement. Parties shall nominate two persons each from their senior management within 10 days of a dispute arising.
 - ii. If no amicable settlement is arrived at within 30 days, then any party may refer the dispute to sole arbitrator to be nominated by Head of the BHEL Unit/Region/Division issuing the Contract. The place of arbitration shall be at Thirumayam. All arbitration proceedings shall be conducted in English in accordance with the provisions of the Arbitration and Conciliation Act, 1996.
 - iii. All disputes shall be subject to the exclusive jurisdiction of the Courts at Pudukkottai.

Place
Date

Signature of the Bidder
(NAME & ADDRESS WITH SEAL)



Bharat Heavy Electricals Limited

(A Govt. of India Undertaking)

Power Plant Piping Unit, Thirumayam – 622 507, Tamil Nadu

Tender Notice

Checklist for Documents to be submitted to HR/Welfare Section*				
S.No	Document type	Scheduled Date	Periodicity	Remarks
1	PF Registration code	On Award of contract/ on production of First bill	One time/as and when required by BHEL	
2	ESI/Group Insurance Code	On award of Contract	One time/as and when required by BHEL	
3	Form VI-A & VI-B under Contract labour (R&A) Act	On commencement and Completion of the Contract	Twice (Once on commencement and once on completion of contract)	Form VI-A to be submitted to Labour authorities and a copy to submitted to Welfare section. Form VI-B (to be prepared and endorsed by User/executing Department) to be submitted to Welfare Section
4	Labour License	To be obtained immediately from Labour authorities in case of engagement of 20 or more contract workers	One time/ on renewal of License / as and when required by BHEL	
5	Bio Data form with proper ID proof	To be submitted for all employees immediately on award of contract and as and when new employees are engaged	One time / as and when required by BHEL	Required for providing ID cards to enable entry into Factory premises and for record purpose
6	Attendance Register	To be submitted on or before 5th of every month	Monthly	To be endorsed by the contractor and BHEL authorised executive/Line Executive
7	Wage Register	To be submitted on or before 10th of every month	Monthly	To be endorsed by the contractor and BHEL authorised executive/Line Executive
8	PF remittance challan & PF - ECR	To be submitted on or before 10th of every month	Monthly	To be checked and cleared by HR Dept

***The checklist is indicative, the contractor is obliged to produce any other document required, in compliance with extant statutes and BHEL practice, as and when required.**

Place
Date

Signature of the Bidder
(NAME & ADDRESS WITH SEAL)



Bharat Heavy Electricals Limited

(A Govt. of India Undertaking)

Power Plant Piping Unit, Thirumayam – 622 507, Tamil Nadu

Tender Notice

IV. CONDITIONS RELATED TO THE WELFARE OF LABOURS:

1. The successful contractor has to have his own PF, ESI / Group Insurance registration and comply with the relevant Acts. If not available immediately / already applied / pending with PF authorities, then an undertaking to comply shall be submitted on award of contract.
2. The Contractor has to remit PF for his workers for the same amount which he paid as total wages to the employees on monthly basis. He has to remit 13% from his side and deduct 12% of Wages from the monthly wages of the employees and a total of 25% of monthly wages should be remitted as PF i.e. each employee. The percentages mentioned are indicative in nature. The PF shall be remitted as per the existing Government guidelines.
3. The Contractor has to produce the PF Registration Code for his workers as per the Government rules while submitting the first bill. The first bill will be processed only on production of the above code. For subsequent bills, the PF remittance challan (for the billing period) for the engaged labor has to be submitted for bill processing.
4. BHEL will not be liable for any medical attention, injury / loss of life of the persons engaged by the contractor during the work inside the factory premises as per the contract. A suitable insurance coverage (ESI / Group Insurance) for the employees shall be arranged by the Contractor at his cost from the first day of operation, towards medical treatment and compensation of any loss as per legal provisions.
5. The contractor shall have full control over his employees including the right to appoint, determine service conditions, discharge, dismiss, or otherwise terminate their services at any time. The contractor shall be solely responsible for any claim arising out of employment or termination of employment of his employees and for statutory payments.
6. In case, during the contract period if ESI scheme comes into effect, the contractor shall conform to the statutory requirements and any additional cost involved shall be borne by the contractor only.
7. The contractor shall employ such personnel who are medically fit and above the age of 18 only. The company has the right to direct the contractor to remove from the premises such of his personnel who may be physically, hygienically, clinically or medically found to be unfit.
8. The upper age limit for the contract employees deployed by the contractors is restricted to sixty.
9. The Minimum Wages as prescribed by the State Government from time to time should be paid to the contract Workers and the Wage and Attendance Registers should be produced to HR department every month. The minimum wages are given below for reference: (w.e.f 01/04/2022)

Sl. No.	Category	Minimum Wages per day (Rs.)		
		Basic	DA	Total
1	Unskilled Worker	258.50	236.19	494.69
2	Semi-Skilled Worker	271.00	236.19	507.19
3	Skilled Worker	278.50	236.19	514.69
4	Supervisor	295.00	236.19	531.19

(The above table is for illustrative purpose only. Latest Govt circular shall be followed.)

Place
Date

Signature of the Bidder
(NAME & ADDRESS WITH SEAL)



Bharat Heavy Electricals Limited

(A Govt. of India Undertaking)

Power Plant Piping Unit, Thirumayam – 622 507, Tamil Nadu

Tender Notice

10. If the contractor employs more than twenty employees, he has to obtain license to this effect from the Factory Inspectorate and renew the same periodically.
11. The Contract workers should be fully aware of safety measures and observe all safety precautions during work. The contractor should also make his own arrangements to provide requisite safety devices to the workers, based on the nature of work. Any accident/incident occurring to his workers in Company's premises should be reported in writing by the Contractor to Safety, Welfare and Line Executive concerned.
12. A list containing the name of working persons' photo, address, age, designation, nature of work is to be furnished immediately on receipt of the contract/work order. This is required for our records and issuance of Identity Card for Gate entry.
13. The canteen charges (cost of the food items and beverages) for contract workmen will be charged if availed, at the rate fixed by BHEL from time to time BHEL's Policy.
14. **The contractor has to disburse the salary/wages for their workmen only through Bank Account. The relevant Bank statement/proof for Bank payment should be produced along with PF and ESI and challans to Welfare Section every month.**
15. Minimum Bonus of 8.33% as applicable shall be paid to the contract employees as per the Payment of Bonus Act 1965.
16. The Contractor shall in respect of labour employed by him, comply with the following statutory provisions, rules & in regard to all matters provided therein.
 - a. The Workmen Compensation Act 1923,
 - b. The Payment of Wages Act 1936 and the related Tamil Nadu Rules,
 - c. The Industrial Disputes Act 1947,
 - d. The Factories Act 1948 and the related Tamil Nadu Rules,
 - e. The Minimum Wages Act 1948 and the related Tamil Nadu Rules,
 - f. Employee's Provident Funds & Miscellaneous Provisions Act 1952,
 - g. The Payment of Bonus Act 1965.
 - h. The Contract labour (Regulation & Abolition) Act 1970 and the related Tamil Nadu Rules.
 - i. The Building and Other Construction Works (RE & CE) Act, 1996 and the related Tamil Nadu Rules.

Place
Date

Signature of the Bidder
(NAME & ADDRESS WITH SEAL)



Bharat Heavy Electricals Limited

(A Govt. of India Undertaking)

Power Plant Piping Unit, Thirumayam – 622 507, Tamil Nadu

Tender Notice

V. GENERAL TERMS & CONDITIONS

i. **DEFINITION:** In these General Conditions of Contract, the following terms shall have the meaning hereby assigned to them, except where the context otherwise requires:

- a) The "**Contract**" means, the documents forming the tender and acceptance thereof, together with all the documents referred to therein including general and special conditions to contract. All these documents as applicable taken together shall be deemed to form one contract and shall be complementary to one another.
- b) The "**work**" means, the work described in the tender documents in individual work-orders as may be issued from time to time to the contractor by the Officer In-charge within the power conferred upon him including all notified or additional items of works and obligations to be carried out as required for the performance of contract.
- c) The "**contractor**" means, the individual Firm or Company whether incorporated or not, undertaking the work and shall include the legal personal representatives of such individuals or the persons composing the firm or Company or the successors of the firm or company and the permitted assigns of such individual or firm or Company.
- d) "The **Officer-In charge**" means, the Officer deputed by the Head of Dept. /Executing Dept., to supervise the work or part of the work.
- e) "**Approved**" and "**Directed**" means, the approval or direction of Head of Unit/PPPU-THIRUMAYAM, or person deputed by him for the particular purposes.
- f) "BHARAT HEAVY ELECTRICALS LIMITED" (herein after referred to as BHEL) shall mean the Board of Directors, Chairman, Executive Director, General Manager or other Administrative Officer of the said Company including Executive/CONTRACTS/PPPU authorized to invite tenders and enter into contract for works on behalf of the Company.
- g) The "**Contract sum**" means, the sum accepted or the sum calculated in accordance with the prices accepted in tender and / or the contract rates as payable to the contractor for the execution of the work during the currency of the contract.
- h) A "**week**" means, Seven Days, without regard to the number of hours worked or not worked in any day in that week.
- i) A "**day**" means, the day of 24 hours (TWENTY-FOUR) irrespective of the number of hours worked or not worked in that day.
- j) A "**working day**" means, any day other than that prescribed by the NEGOTIABLE INSTRUMENTS ACT as being a Holiday, and consists of the number of hours of labour as commonly recognized by good employers in the trade in the district where the work is carried out or as laid down in the BHEL regulations.

ii. **HEADING TO THE CONTRACT CONDITIONS:** The heading to these conditions shall not affect the interpretations thereof.

iii. **WORK TO BE CARRIED OUT:** The Contract shall, include all labour, materials, tools, plant, equipment and transport which may be required for the execution of the work. The Contractor will be deemed to have satisfied himself as to the nature of the site, local facilities of access and all matters affecting the execution of the work. No extra charges consequent on any misunderstanding in these respects or otherwise will be allowed.

iv. **ORDERS UNDER THE CONTRACT:** All orders, notices etc. to be given under the contract shall be in e-mail, writing, type-script or printed and if sent by registered post to the address given in the tender of the Contract, shall be

Place
Date

Signature of the Bidder
(NAME & ADDRESS WITH SEAL)



Bharat Heavy Electricals Limited

(A Govt. of India Undertaking)

Power Plant Piping Unit, Thirumayam – 622 507, Tamil Nadu

Tender Notice

deemed to have been served on the date, when in the ordinary course they would have been delivered to him. The Contractor shall carry out without delay all orders given to him.

- v. **DEVIATIONS:** The contractor shall not carry out any work not covered by schedule except in pursuance of the written instructions of HOD/Contracts Dept. No such work shall be valid unless the same has been specifically confirmed and accepted by BHEL in writing and incorporated in the Contract.
- vi. **ASSIGNMENT OF TRANSFER OF CONTRACT:** The Contractor shall not without the prior written approval of the BHEL, assign or transfer the contract or any part thereof, or any share, or interest thereon to any other persons. No sum of money which may become payable under the contract shall be payable to any person, other than the contractor unless the prior written approval of the BHEL to the assignment or transfer of such money is given.
- vii. **COMPLIANCE TO REGULATIONS AND BY-LAWS:** The Contractor shall confirm to the provisions of any statute relating to the work and regulations and Bye-Laws of any local authority. The Contractor shall be bound to give all notices required by statute regulations or By-Laws as aforesaid and to pay all fees and taxes payable to any authority in respect thereof.
- viii. **GOODS & SERVICE TAX (GST) REGISTRATION & COMPLIANCE:**
1. Response to Tenders for Indigenous supplier will be entertained only if the vendor has a valid GST registration No (GSTIN) which should be clearly mentioned in the offer. If the dealer is exempted from GST registration, a declaration with due supporting documents need to be furnished for considering the offer. Dealers under composition scheme should declare that he is a composition dealer supported by the screen shot taken from GST portal. The dealer has to submit necessary documents if there is any change in status under GST.
 2. Supplier shall mention their GSTIN in all their invoices (incl. credit Notes, Debit Notes) and invoices shall be in the format as specified/prescribed under GST laws. Invoices shall necessarily contain Invoice number (in case of multiple numbering system is being followed for billing like SAP invoice no, commercial invoice no etc., then the Invoice No. which is linked/uploaded in GSTN network shall be clearly indicated), Billed to party (with GSTIN) & Shipped to party details, item description as per PO, Quantity, Rate, Value, applicable taxes with nomenclature (like IGST, SGST, CGST & UTGST) separately, HSN/ SAC Code, Place of Supply etc.
 3. All invoices shall bear the HSN Code for each item separately (Harmonized System of Nomenclature)/ SAC code (Services Accounting Code).
 4. Invoices will be processed only upon completion of statutory requirement and further subject to following: a. Vendor declaring such invoice in Form GST ANX-1
b. Receipt of Goods or Services and Tax invoice by BHEL
 5. As the continuous uploading of tax invoices in GSTN portal (in GST ANX-1) is available for all (i.e. both Small & Large) tax payers under proposed new GST Return System, all invoices raised on BHEL may be uploaded immediately in GST portal on dispatch of material /rendering of services. The supplier shall ensure availability of Invoice in GST portal before submission of invoice to BHEL. Invoices will be admitted by BHEL only if the invoices are available in GSTN portal (in BHEL's GST ANX-2).
 6. In case of discrepancy in the data uploaded by the supplier in the GSTN portal or in case of any shortages or rejection in the supply, then BHEL will not be able to avail the tax credit and will notify the supplier of the same. Supplier has to rectify the data discrepancy in the GSTN portal or issue credit note or debit note (details also to be uploaded in GSTN portal) for the shortages or rejections in the supplies or additional claims, within the calendar month informed by BHEL.
 7. In cases where invoice details have been uploaded by the vendor but failed to remit the GST amount to GST Department (Form PMT-08 or Form GST RET-01 to be submitted) within stipulated time, then GST paid on the invoices pertaining to the month for which GST return not filed by the vendor will be recovered from the vendor along with the applicable interest (currently 24% p.a) and all subsequent bills of the vendor will not be processed till filing of the GST return by the vendor

Place
Date

Signature of the Bidder
(NAME & ADDRESS WITH SEAL)



Bharat Heavy Electricals Limited

(A Govt. of India Undertaking)

Power Plant Piping Unit, Thirumayam – 622 507, Tamil Nadu

Tender Notice

8. In case GST credit is denied to BHEL due to non-receipt or delayed receipt of goods and/ or tax invoice or expiry of timeline prescribed in GST law for availing such ITC, or any other reasons not attributable to BHEL, GST amount claimed in the invoice shall be disallowed to the vendor.
9. Where any GST liability arising on BHEL under Reverse Charge (RCM), the vendor has to submit the invoices to BHEL well within the timeline prescribed in GST Law, to enable BHEL to discharge the GST liability. If there is a delay in submission of invoice by the vendor resulting in delayed payment of GST by BHEL along with Interest, then such Interest payable or paid shall be recovered from the vendor.
10. Under GST regime, BHEL has to discharge GST liability on LD recovered from suppliers/contracts. Hence applicable GST shall also be recoverable from suppliers/contractors on LD amount. For this Tax Invoice will be issued by BHEL indicating the respective supply invoice number.

GST TDS will be deducted as per Section 51 of CGST Act 2017 and in line with Notification 50/2018 – Central Tax dated 13.09.2018. GST TDS certificate which will be generated in GST portal subsequent to vendor accepting the TDS deduction in the GST portal, will be issued to the vendor.

ix. SECURITY DEPOSIT

Amount of 5% of the contract value (Excluding GST) shall be deposited before start of the Work as Security Deposit. Failure to remit the Security Deposit shall be treated as failure to discharge the duties under the contract and shall result in cancellation of the contract and the bidder shall be liable to compensate BHEL for any loss. EMD in such cases shall be forfeited.

The Security Deposit may be furnished in any one of the following forms:

1. Remittance through online SBI-State Bank Collect.
2. Pay Order, Demand Draft in favour of **BHEL Trichy**.
3. Local cheques of scheduled banks, subject to realization.
4. Securities available from Post Offices such as National Savings Certificates, Kisan Vikas Patras etc. (Certificates should be held in the name of Contractor furnishing the security and duly pledged in favour of BHEL and discharged on the back).
5. Bank Guarantee from Scheduled Banks/ Public Financial Institutions as defined in the Companies Act. The Bank Guarantee format should have the approval of BHEL and **with minimum validity covering the contract period + 6 months & maintenance period if any**.
6. In order to ensure the genuineness of BG's, the BG's are to be sent directly by the concerned bank through registered post to CONTRACTS DEPT/PPPU, BHEL Thirumayam.
7. Security deposit can also be recovered at the rate of 10% from the running bills. However, in such cases at least 50% of the Security Deposit should be paid before commencement of work (any of the above form) and the balance 50% may be recovered from the running bills.
8. For contract value less than Rs 20 lakh, work may be started after issue of LOI without remittance of SD. From the first bill, 50% of SD will be collected, and the balance will be recovered from the running bills at the minimum rate of 10% of gross SD.

The security deposit shall not carry any interest.

The Earnest Money paid at the time of tender will be adjusted as part of the Security Deposit and the balance amount will be collected from the contractor as mentioned above.

Security Deposit shall not be refunded except in accordance with the terms of the Contract or Agreement. No interest shall be allowed on Security Deposits. BHEL shall not be responsible for any loss of securities, due to liquidation for any other reasons, what-so-ever or any depreciation in the value of the securities while in their charge or for any loss of interest there on.

Place
Date

Signature of the Bidder
(NAME & ADDRESS WITH SEAL)



Bharat Heavy Electricals Limited

(A Govt. of India Undertaking)

Power Plant Piping Unit, Thirumayam – 622 507, Tamil Nadu

Tender Notice

All compensation or other sums of money payable by the Contractor to BHEL under the terms of this contract or under any other contract with BHEL may be deducted from the Security Deposit or realised by the sale of the securities or from the interest arising there from or from any sums which may be due or may become due to the contractor by BHEL and in the event of this Security Deposit being deducted by reason of such deductions or sale, as aforesaid, the Contractor shall within 7 days thereafter, make good in cash or in securities endorsed as aforesaid, any sum by which the Security Deposit has been reduced.

9. Set off Clauses

Payment of bills, payment of any amounts due, release of Security Deposit or return of Bank Guarantees furnished under this tender/contract, shall be subject to the deduction of any amount for which the Bidder is liable under this contract, or any contract placed on the contractor by BHEL, Piping Centre, Chennai or any/all other Unit/s of BHEL.

10. REFUND OF SECURITY DEPOSIT:

Security Deposit will be refunded on completion of the work and after the expiry of the maintenance period, if any, provided always that the Contractor shall first have been paid the last and final bill and have rendered a "NO DEMAND CERTIFICATE". In case no maintenance period is applicable, then 100% of security Deposit will be refunded after providing "No Demand" certificate by the contractor as per the "Refund of Security Deposit" format.

11. CONTRACTOR'S SUPERVISION:

1. The Contractor or his accredited agent shall attend when required without making any claim for doing so, either the office of the Executive/CONTRACTS or the OFFICER-INCHARGE, to receive instructions.
2. Orders given to the Contractor's agent shall be considered to have the same force as if they have been given to the Contractor himself.
3. BHEL-PPPU, THIRUMAYAM shall have full powers and without assigning any reason, require the Contractor to immediately cease to employ in connection with this contract, any agent, servant or employee where continued employment is, in his opinion undesirable. The Contractor shall not be allowed any compensation on this account.

12. LABOUR:

The Contractor shall remain liable for the payment of all wages or other moneys to his work-people or employees under the payment of Wages Act 1936, Employees Liability Act. 1938, Workmen's Compensation Act 1923 or any other Act or enactment, relating thereto and rules framed, there under from time to time.

- ### **13. PRECAUTIONS AGAINST RISK:**
- The Contractor shall be responsible for providing at his own expense for all precautions to prevent loss or damage from any and all risks and to minimize the amount of any such loss or damage and for the necessary steps to be taken for the said purpose.

- ### **14. DAMAGE & LOSS TO PRIVATE PROPERTY & INJURY TO WORKMEN :**
- The Contractor shall at his own expense reinstate and make good to the satisfaction of the HOD/Executing Dept., and pay compensation for any injury, loss or damage occurred to any property or rights whatever including property and rights of BHEL (or agents) servants or employee of BHEL, the injury loss or damage arising out of or in any way in connection with the execution or purported execution of the contract and further the contractor shall indemnify, the BHEL against all claims enforceable against BHEL (or any agent, servant or employee of BHEL) or which would be so enforceable against BHEL where BHEL is a private person, in respect of any such injury (including injury resulting in death) loss

Place
Date

Signature of the Bidder
(NAME & ADDRESS WITH SEAL)



Bharat Heavy Electricals Limited

(A Govt. of India Undertaking)

Power Plant Piping Unit, Thirumayam – 622 507, Tamil Nadu

Tender Notice

or damage to any person whomsoever or property including all claims which may arise under the Workmen's Compensation Act or otherwise.

15. LAWS GOVERNING THE CONTRACT:

The contract shall be governed by the Indian Laws for time being in force.

- (i) Should a tenderer or a contractor has a dependent/relative or in the case of a partnership firm, any of its partners or dependents of partners employed in BHEL, the authority inviting tenders should be informed of this fact at the time of submission of the tender failing which tender may be disqualified or if such fact subsequently come to light, the contract may be cancelled.
- (ii) No BHEL employee and their dependents are eligible to submit their offer against this tender.

16. CANCELLATION OF CONTRACT FOR CORRUPT ACTS:

BHEL, whose decision shall be final and conclusive, shall without prejudice to any other right or remedy which shall have accrued shall accrue thereafter to BHEL cancel the contract in any of the following cases and the Contractor shall be liable to make payment to BHEL for any loss or damage resulting from any such cancellation to the same extent as provided in the case of cancellation for default. If the Contractor shall: -

1. Offer or give or agree to give to any person in BHEL service any gift or consideration of any kind, as an inducement or reward for doing or for bearing to do or for having done or for borne to do any act, in relation to the obtaining or execution of this or any other contract for BHEL service,
OR
2. Enter in to a contract with BHEL in connection with which commission has been paid or agreed to be paid by him or with his knowledge, unless the particulars of any such commission and the terms of payment thereof have previously been disclosed in writing to BHEL.
OR
3. Obtain a contract with BHEL as a result of ring tendering or by non-bonafide methods of competitive tendering, without first disclosing the fact in writing to BHEL.

17. CANCELLATION OF CONTRACT IN PART OR FULL FOR CONTRACTOR'S DEFAULT:

If the Contractor:

1. makes default in carrying out the work as directed and continues in that state after a reasonable notice from HOD/Executing Dept., or his authorised representative;
2. fails to comply with any of the Terms and Conditions of the contract or after reasonable notice in writing with orders properly issued there under;
3. BHEL, may without prejudice to any other right or remedy which shall have accrued or shall accrue thereafter to BHEL CANCEL the contract as whole or in part thereof or only such work order or items of work in default from the contract. Whenever BHEL exercise the authority to cancel the contract as whole or part under this condition BHEL may complete the work at the contractor's risk and cost (as certified by HOD/Executing Dept., which is final and conclusive) being less than the contract cost, the advantage shall accrue to the BHEL. If the cost exceeds the moneys due to the Contractor under this contract the Contractor shall either pay the excess amount ordered by HOD/Contracts Dept. or his authorized representative or the same shall be recovered from the Contractor by other means. In case the BHEL carries out the work or any part thereof under the provisions of the conditions the cost to be taken into account in determining the excess cost to be

Place
Date

Signature of the Bidder
(NAME & ADDRESS WITH SEAL)



Bharat Heavy Electricals Limited

(A Govt. of India Undertaking)

Power Plant Piping Unit, Thirumayam – 622 507, Tamil Nadu

Tender Notice

charged to the Contractor under this condition shall consist of the cost of the materials, hire charges of tools and plant and/or labour provided by the BHEL with an addition of such percentage to cover the superintendence and establishment charges as may be decided by the HOD/Executing Dept. & Contracts Dept., whose decision shall be final and conclusive.

18. CANCELLATION OF CONTRACT FOR INSOLVENCY, ASSIGNMENT OF TRANSFER OR SUB-LETTING OF CONTRACT:

BHEL, without prejudice to any other right or remedy which shall have accrued or shall accrue thereafter to BHEL shall cancel the contract in any of the following cases:

If the Contractor,

1. being an individual or if a firm any partner thereof shall at any time be adjudged bankrupt or have a receiving order for administration of his estate, made against him or shall take any proceedings for liquidation or composition under any bankruptcy Act or assignment of his effects of composition or arrangement for the benefit of his creditors or purport to do so, or if any application made under any Bankruptcy Act for the time being in force for the sequestration of his estate or if a trust deed be granted by him on behalf of his creditors

OR

2. being a Company, shall pass a resolution or the Court shall make an order for the liquidation of its affairs, or a receiver or Manager on-behalf of the debenture holders shall be appointed or circumstances shall arise which entitle the Court or debenture holders to appoint a receiver or Manager, OR
3. Assigns, Transfers, attempts to assign, transfer any portion of the work without the prior written approval of the BHEL. OR
4. Sub-lets or attempt to sub-let any portion of the work.

OR

5. Fails to carry out the work and unauthorized absence for more than 3 days.

OR

6. Whenever BHEL exercise the authority to cancel the contract under these conditions, BHEL may have the work done by any means at the Contractor's risks and expenses provided always that in the event of the cost of the work so done (as certified by EXECUTIVE/CONTRACTS/PPPU which is final and conclusive) being less than the contract cost, the advantage shall accrue to the BHEL and if the cost exceeds the money due to Contractor under the contract, the Contractor shall either pay the excess amount ordered by HOD/Contracts Dept. or his authorized representative, or the same shall be recovered from the Contractor by other means.

OR

7. In case the BHEL carries-out the work under the provisions of this condition the cost to be taken into account in determining the excess cost to be charged to the Contractor under this condition shall consist of the cost of the materials, hire charges of tools and plants and/or labour provided by the BHEL with an addition of such percentage to cover superintendence and establishment charges as may be decided by the HOD/Executing Dept. & Contracts Dept., whose decision shall be final and conclusive.

19. TERMINATION OF CONTRACT ON DEATH OF CONTRACTOR:

Without prejudice to any of the rights or remedies under this contract, if the Contractor dies, or if the firm is dissolved or the company is liquidated, BHEL shall have the option of terminating the contract without compensation to the Contractor.

Place
Date

Signature of the Bidder
(NAME & ADDRESS WITH SEAL)



Bharat Heavy Electricals Limited

(A Govt. of India Undertaking)

Power Plant Piping Unit, Thirumayam – 622 507, Tamil Nadu

Tender Notice

20. SPECIAL POWER TO TERMINATION: If at any time after the award of contract, BHEL shall for any reason whatsoever not require whole or any part of the work to be carried out, the HOD/Contracts Dept. or his authorized representative, shall give notice in writing of the fact to the Contractor who shall have no claim to any payment of compensation or otherwise howsoever on account of any profit or advantage which he might have derived from the execution of the work in full but which he did not derive in consequence of the foreclosing of the work.

21. RECOVERY FROM CONTRACTOR:

Whenever under the contract, any sum of money, shall be recoverable from or payable by the Contractors, the same may be deducted from or any sum then due or which at any time thereafter may become due to Contractor under the contract or under any other contract with BHEL or he shall pay the claim on demand.

22. POST TECHNICAL AUDIT OF WORK AND BILLS: -

BHEL reserves the right to carry out the post-payment Audit and technical examination of the work and final bill including all supporting vouchers, abstracts etc., and enforce recovery of any sum becoming due as a result thereof. However, no such recovery shall be enforced after three years of passing the final bill.

23. PREFERENCE TO MAKE IN INDIA: For this procurement, the local content to categorize a supplier as a Class I local supplier/ Class II local Supplier/ Non Local supplier and purchase preference to Class I local supplier, is as defined in Public Procurement (Preference to Make in India), Order 2017 dated 04.06.2020 issued by DPIIT. In case of subsequent orders issued by the nodal ministry, changing the definition of local content for the items of the NIT, the same shall be applicable even if issued after issue of this NIT, but before opening of Part-II bids against this NIT.

24. FORCE MAJEURE CLAUSE: If, at any time during the continuance of this Contract the performance in whole or in part by either party of any obligations under this Contract shall be prevented or delayed by reason of any War, Hostile acts of the public enemy Civil Commotion, Epidemics, or Acts of God (Floods, Storm/Cyclone, Hurricane, Earth Quake etc.) then provided notice of happening of any such event is given by either party to other within 7 days from the date of occurrence therefore neither party shall by reason of such event be entitled to terminate this Contract nor shall either party have any claim for damages against the other in respect of such nonperformance and delay in performance under the contract shall be resumed as soon as practicable after such event has come to an end or ceased to exist. If the performance in whole or part of any obligation under this Contract is prevented or delayed by reason of any such event, claims for extension of time shall be granted for periods considered reasonable by the Executive/Contracts/PPPU subject to prompt notification by the contractor.

25. ARBITRATION & CONCILIATION:

Except as provided elsewhere in this Contract, in case amicable settlement is not reached between the Parties, in respect of any dispute or difference; arising out of the formation, breach, termination, validity or execution of the Contract; or, the respective rights and liabilities of the Parties; or, in relation to interpretation of any provision of the Contract; or, in any manner touching upon the Contract, then, either Party may, by a notice in writing to the other Party refer such dispute or difference to the sole arbitration of an arbitrator appointed by Head of the BHEL Unit/Region/Division issuing the Contract.

1. The Arbitrator shall pass a reasoned award and the award of the Arbitrator shall be final and binding upon the Parties.

Place
Date

Signature of the Bidder
(NAME & ADDRESS WITH SEAL)



Bharat Heavy Electricals Limited

(A Govt. of India Undertaking)

Power Plant Piping Unit, Thirumayam – 622 507, Tamil Nadu

Tender Notice

2. Subject as aforesaid, the provisions of Arbitration and Conciliation Act 1996 (India) or statutory modifications or re-enactments thereof and the rules made thereunder and for the time being in force shall apply to the arbitration proceedings under this clause. The seat of arbitration shall be Pudukkottai.
3. The cost of arbitration shall be borne as per the award of the Arbitrator.
4. Subject to the arbitration in terms of Clause above, the Courts at Pudukkottai shall have exclusive jurisdiction over any matter arising out of or in connection with this Contract.
5. Notwithstanding the existence or any dispute or differences and/or reference for the arbitration, the Contractor shall proceed with and continue without hindrance the performance of its obligations under this Contract with due diligence and expedition in a professional manner except where the Contract has been terminated by either Party in terms of this Contract.

In case of Contract with Public Sector Enterprise (PSE) or a Government Department, the following shall be applicable: In the event of any dispute or difference relating to the interpretation and application of the provisions of the Contract, such dispute or difference shall be referred by either Party for arbitration to the sole arbitrator in the Department of Public Enterprises to be nominated by the Secretary to the Government of India in-charge of the Department of Public Enterprises. The Arbitration and Conciliation Act, 1996 shall not be applicable to arbitration under this clause. The award of the arbitrator shall be binding upon the Parties to the dispute, provided, however, any Party aggrieved by such award may make further reference for setting aside or revision of the award to the Law Secretary, Department of Legal Affairs, Ministry of Law and Justice, Government of India. Upon such reference the dispute shall be decided by the Law Secretary or the Special Secretary or Additional Secretary when so authorized by the Law Secretary, whose decision shall bind the Parties hereto finally and conclusively. The Parties to the dispute will share equally the cost of arbitration as intimated by the Arbitrator.

26. JURISDICTION:

In case of any suit or other legal proceedings arising under or relating to this Contract, the courts at Pudukkottai, Tamil Nadu only shall have the Jurisdiction and is only after exhausting the, Arbitration, Clause 25.

27. SIGNING OF CONTRACT: Each contract document shall be signed by the Contractor with his usual signature. Contract by partnership of Hindu Joint Family firm, may be signed in the FIRM'S name by one of the Partners or the Karta or Manager as the case may be or by any other duly authorised representative followed by the name and designation of the persons so signing. Contracts by a Company shall be signed with the name of the Company by a person authorised in this behalf and a power of attorney or other satisfactory proof showing that the persons signing the Contract documents on behalf of the Company is duly authorised to do so, shall accompany the contract.

28. SECRECY OF CONFIDENTIAL INFORMATION:

The Contractor undertakes and agrees that he/it will not disclose or reveal in part or full the proprietary/confidential information, which terms shall mean and include patents, trademarks, service marks, registered designs, copyright, design rights, know-how, confidential information, trade and business names and any other similar protected information of BHEL received during negotiation or currency of the contract to any third party or governmental authorities without written permission from BHEL. In the event of termination or expiry of the contract, the contractor shall return all proprietary/confidential information to BHEL. This clause shall survive termination or expiry of the contract. BHEL reserves the right to initiate appropriate action

Place
Date

Signature of the Bidder
(NAME & ADDRESS WITH SEAL)



Bharat Heavy Electricals Limited

(A Govt. of India Undertaking)

Power Plant Piping Unit, Thirumayam – 622 507, Tamil Nadu

Tender Notice

including legal proceeds / termination of contract, recovery of damages, penalties etc., if the contractor is found guilty / wrong usage of the documents given by BHEL for any unauthorized activity.

29. STATUTORY REQUIREMENTS:

- a) All statutory requirements under Minimum Wages Act, 1948, Factories Act 1948, Workmen Compensation Act 1923, Employees Provident Fund and Miscellaneous Provisions Act, 1952, Payment of Gratuity Act 1972, Employee State Insurance Act 1948, Contract Labour (Regulation and Abolition) Act 1970, Payment of Bonus Act 1965, Income Tax Act, GST / SGST / IGST / UTGST Act and all other applicable Acts shall be complied with by the Contractor.
- b) Contractor shall comply with all statutory requirements, rules, regulations, notifications in relation to employment of his employees issued from time to time by the concerned authorities.
- c) Contractor shall indemnify BHEL against all claims and losses under various Labour Laws, statutes or any civil or criminal law in connection with employees deployed by him.
- d) Contractor wherever applicable shall maintain proper records prescribed by the concerned statutory authorities and provide a copy of the same to BHEL.
- e) Contractor shall furnish proper returns to the concerned statutory authorities and provide a copy of the same to BHEL.

30. REGISTERS & RECORDS:

The Contractor shall maintain all registers and records in the proper manner and as required by the regulations of the various authorities concerned and indemnify the Employer from the consequences due to any inaccurate or faulty documentation on the part of the Contractor.

31. REMOTE TRANSACTIONS:

The Contractor shall agree to and comply with all such terms and conditions as BHEL may prescribe from time to time and shall confirm that all transactions effected by or through facilities for conducting remote transactions including the Internet, World Wide Web, electronic data interchange, call centers, teleservice operations (whether voice, video, data or combination thereof) or by means of electronic, computer, automated machines network or through other means of telecommunication established by BHEL shall constitute legally binding and valid transactions when done.

32. CHANGE IN CONSTITUTION OF FIRM:

Changes in constitution of firm whenever it is made after submission of application or during currency of the contract, the existing firm has to duly inform the proposed changes to contracting department of BHEL at the appropriate time before the changes in the constitution are made. In case the absence of any such information BHEL is not responsible for the consequences arising out of the absence or suppression of information and the issue / dispute arising out of these changes and the firm is responsible for settling the issue or dispute among themselves (Partners etc.) or with the bankers or with any third party. Under the above circumstances when dispute arises and the firm does not inform the change in the constitution of the firm BHEL may reserve its rights for suspending or terminating the contract.

33. FRAUD PREVENTION POLICY:

The Bidder along with its associate / collaborators / sub-contractors / sub-vendors / consultants / service providers shall strictly adhere to BHEL Fraud Prevention Policy displayed on BHEL website <http://www.bhel.com>

Place
Date

Signature of the Bidder
(NAME & ADDRESS WITH SEAL)



Bharat Heavy Electricals Limited

(A Govt. of India Undertaking)

Power Plant Piping Unit, Thirumayam – 622 507, Tamil Nadu

Tender Notice

and shall immediately bring to the notice of BHEL Management about any fraud or suspected fraud as soon as it comes to their notice.

34. COMMON TERMS AND CONDITIONS FOR WORKS CONTRACT RELEVANT TO SAFETY

1. Contract employees working on BHEL premises must wear appropriate personal protective equipment. Strict adherence to all required Personal Protective Equipment (Helmet, Safety Shoes and Goggles) are mandatory, specific PPE requirements will be based on job type or tasks performed. Contractor should submit proof for bringing the necessary PPEs inside the factory along with the monthly bills to the user department.
2. Excessively loose-clothing, dhoti/Lungi is prohibited especially around rotating or moving equipment.
3. The contractors' work area should be kept clean and orderly, free of clutter and trash, so that work may proceed in a safe and orderly manner. Tools should be safely positioned during use and promptly put away when no longer required.
4. Fire-fighting, emergency shutdown devices, and life-saving equipment, should not be blocked by the contractor/employees and access to the path to this equipment should be maintained at all times.
5. Only approved equipment should be used in locations where flammable mixtures are present. A Hot Work Permit is required when open flames, or electric arcs are in the work area and while handling flammable materials.
6. Smoking is not allowed in work area.
7. It is recommended that the contractor should know & display the emergency phone numbers like Fire, Ambulance, Safety, Security etc. at their work area.
8. It is the responsibility of the contractor to understand and use the appropriate Work Permits and to verify any permit requirements at the location. Contractor must make necessary arrangements with their Representative to acquire appropriate authorization to perform those operations at the site.
9. Use of cell phones and other mobile electronic devices (including hands-free devices) in the work spot and during the operation of a vehicle in the BHEL premises is prohibited.

35. SAFETY CONDITIONS: Tamil Nadu Factories Rules, 1950

- Rule 61F: Methods of Work: No process or work shall be carried on in any factory in such a manner as to cause risk of bodily injury.
- Rule 61G: Stacking and storing of materials etc.: No materials or Equipment shall be stacked or stored in such a manner as to cause risk of bodily injury.
- Rule 61-N and Rule 61- O: Workers to be provided with Personal Protective equipment suitable for the hazards and should be of good quality / have certification by Indian Standard Institute.
- Rule 96: Notification of Accidents: Shall be complied with as required in the Factories Act (Section 88 and Section 88A) and Tamil Nadu Factories Rules.

The following safety measures (whichever is applicable) should be strictly adhered to during execution of works at sites.

1. Providing the working platform with toe board and handrail for continuous working at heights.
2. Providing safety belt and life line at all times for men working at heights.
3. Providing dust or fume respirator in places where dust and fume concentration exists.
4. Providing goggles and welding screens.
5. Providing acid and alkali proof rubber gloves for handling acid and alkali and chemical which are corrosive.

Place
Date

Signature of the Bidder
(NAME & ADDRESS WITH SEAL)



Bharat Heavy Electricals Limited

(A Govt. of India Undertaking)

Power Plant Piping Unit, Thirumayam – 622 507, Tamil Nadu

Tender Notice

6. Providing rubber gloves for working on electrical works.
7. Ensuring proper lashing of the components while being transported in vehicles.
8. The gas cylinders must be always handled on trolleys or kept tied down not in use. They should never be rolled as Roller for conveying.
9. Cylinders should not be used without regulators.
10. All excavations must be barricaded and red lamps must be provided.
11. All electrical connections must be properly earthed.
12. No work should be taken up for execution inside shop floor, without obtaining necessary work permit.
13. Providing helmet, safety belt, etc., for high level work and sufficient number of Industrial Safety nets at appropriate level to safeguard the persons working at high level particularly in trusses, girders, roofing etc., of industrial and high roof buildings.
14. The contractor should maintain a register regarding the driver license particulars.
15. All personal protective equipment conforms with standard specification as per the details given in the code of conduct.
16. Contractor including their sub-contractors, agents and labour engaged on the work are required to scrupulously adhere to the safety regulations, safety precautions and measures. Any violation thereof will invite punitive action being taken against them. Also contractors with frequent violations of safety regulations will not be entrusted with further work in this organization.

36. Safety precautions to be observed while transporting materials (WHICHEVER IS APPLICABLE): -

A) VEHICLE:

- 1) Vehicles carrying material should have proper registration documents and must be produced on demand by our Security Staff.
- 2) The light on right side, i.e. over the driver's cabin shall be in working condition.
- 3) Both the head lights as well as park lamps must be in working conditions.

B) MOVEMENT OF VEHICLE:

1. The vehicle should not travel at more than 20 kmph in our premises.
2. The Driver of the vehicle must possess heavy duty license and produce on demand by the Security Staff.
3. Vehicles carrying inflammable liquid in the tank containers should have grounding chain or the tank should be coated with insulating material also to avoid static electricity.
4. In road junctions, speed breakers and railway crossing, the speed should be lowered and vehicle should proceed cautiously.
5. The driving should "KEEP TO THE LEFT" at all places.
6. The vehicle should not be parked in road which could obstruct the vehicular traffic.
7. The vehicle should pass only through the approved routes. Short cuts should be forbidden.
8. There must be a safe distance behind another moving truck.
9. The driver should avoid making quick starts, jerky stops or quick turns at excessive speed.

Place
Date

Signature of the Bidder
(NAME & ADDRESS WITH SEAL)



Bharat Heavy Electricals Limited

(A Govt. of India Undertaking)

Power Plant Piping Unit, Thirumayam – 622 507, Tamil Nadu

Tender Notice

37. SUSPENSION OF BUSINESS DEALINGS WITH SUPPLIERS /CONTRACTORS:

Penal action can be initiated on the suppliers / Contractors in line with extant 'Guidelines for Suspension of Business Dealings with Suppliers/ Contractors. The abridged version of extant 'Guidelines for suspension of business dealings with suppliers/ contractors' has been uploaded on <http://www.bhel.com> on "supplier registration page".

38. GENERAL:

The vehicles should not be moved directly inside the production building in case the materials are to be unloaded there. But the vehicle should be parked outside the building and the driver should ascertain the passage as well as the unloading points with the help of shop officials. This will avoid the congestion of blocking of traffic in the gangway.

39. NOTICE OF ACCIDENTS:

1. Notwithstanding anything contrary to this, in the event of accident the contractor shall be required to fill injury report and submit the Engineer in charge immediately and ensure the compliances of ESI / Workmen's compensation Act, Factories Act and Rules made thereunder. He shall also maintain a register of accident as per the Act.
2. The Contractor shall get the contract labour engaged by him insured under Workmen's Compensation policy from General Insurance Corporation of India before actually starting the work of contract. The insurance coverage should be for the entire period of Contract. The Contract shall comply with the provisions of the Workmen's Compensation Act 1923. (This should be read in conjunction with the provisions of ESI Act)

40. Government Law's Covering Under This Contract:

The Contractor shall in respect of Personnel employed by him either directly or through sub-Contractors, comply with or cause to be complied with following statutory provisions and rules and in regard to all matters provided therein.

41. The Contract Labour (Regulation & Abolition) Act 1970 and the related Rules:

- a. The minimum wages Act 1948 and the related rules
- b. The payment of wages Act 1936 and the related rules.
- c. The Factories Act 1948 and related Tamil Nadu Rules.
- d. The Employees' Provident Fund & Miscellaneous provisions Act 1952.
- e. The Employees State Insurance Act 1948.
- f. Workmen Compensation Act 1923
- g. Payment of Bonus Act 1965
- h. Maternity Benefit Act, 1961
- i. Payment of Gratuity Act, 1972
- j. Inter-State Migrant Workmen (Regulation of Employment & Conditions of Service) Act, 1979 k. Equal Remuneration Act, 1976
- l. Industrial Employment (Standing Order) Act, 1960 (In case of engaging 100 or more personnel) m. The Industrial Disputes Act 1947

Place
Date

Signature of the Bidder
(NAME & ADDRESS WITH SEAL)



Bharat Heavy Electricals Limited

(A Govt. of India Undertaking)

Power Plant Piping Unit, Thirumayam – 622 507, Tamil Nadu

Tender Notice

And any other law, or modifications to the above or to the rules made there under from time to time.

42. Biometric Entry/Exit System for Contractor's Workmen:

- a) The Entry/Exit of the employees engaged by contractor is to be regulated only through Biometric system.
- b) The Contractor initially will be issued with a temporary gang pass for his/ her employees for a period of ten days.
- c) The contractor should arrange photo coverage for all his/her employees within the above stipulated time.
- d) The contractor has to submit FORM-I for all his/her contract employees. All the particulars required in FORM-I are to be provided by the contractor without fail.
- e) Every employee of the Contractor shall be provided with Employment Card as per Form XIV (as per Rule 76 of the Contract Labour (Central) Rules, 1971 and the contractor shall instruct its employees to carry the Employment Card as well as Entry Card without fail, while entering/exiting factory.
- f) The contractor should educate his employees in registering the attendance through the system.
- g) Whenever a contract employee migrates or leaves service of the contractor, the contractor has to surrender the biometric card of the particular employee to Contract Cell with immediate effect, without fail.
- h) On completion of the work, the contractor has to surrender all the biometric entry cards issued to its employees immediately to the contract cell. Otherwise, an amount of Rs.100/- per card will be deducted from the final bill/security deposit of the contractor.
- i) If any contract employee lose his/her entry card, the contractor shall arrange a duplicate entry card for the employee by paying an amount of Rs.100/-.
- j) The Contractor is totally responsible for the biometric cards issued to his/ her employee.
- k) The Contractor has to indemnify BHEL for all the damages and losses caused by his/her employees.

43. BHEL shall recover the amount of compensation paid to victim(s) by BHEL towards loss of life / permanent disability due to an accident which is attributable to the negligence of contractor, agency or firm or any of its employees as detailed below:

1. Victim: Any person who suffers permanent disablement or dies in an accident as defined below
2. Accident: Any death or permanent disability resulting solely and directly from any unintended and unforeseen injurious occurrence caused during manufacturing / operation and works incidental thereto at BHEL factories / offices and precincts thereof, project execution, erection and commissioning services, repairs and maintenance, trouble shooting, serving, overhaul, renovation and retrofitting, trial operation, performance guarantee testing undertaken by the company or during any works / during working at BHEL Units / offices / townships and premises / Project Sites.
3. Compensation in respect of each of the victims:
 - a. In the event of death or permanent disability resulting from Loss of both limbs: Rs. 10,00,000/- (Rs. Ten Lakh)
 - b. In the event of other permanent disability: Rs. 7,00,000 (Rs. Seven Lakh)
4. Permanent Disablement: A disablement that is classified as a permanent total disablement under provision to Section 2(l) of the Employee's Compensation Act, 1923.

Place
Date

Signature of the Bidder
(NAME & ADDRESS WITH SEAL)



Bharat Heavy Electricals Limited

(A Govt. of India Undertaking)

Power Plant Piping Unit, Thirumayam – 622 507, Tamil Nadu

Tender Notice

RTGS/NEFT FORM

To
THE PURCHASE/CONTRACT EXECUTING AGENCY/BHEL

ACCEPTANCE FOR ELECTRONIC FUND TRANSFER / RTGS TRANSFER

01	Name & Address of the Supplier / Sub-contractor	
02	VENDOR CODE assigned by BHEL	
Details of Bank Account:		
03	NAME & ADDRESS OF THE BANK	
04	NAME OF THE BRANCH	
05	BRANCH CODE	
06	MICR CODE	
07	ACCOUNT NUMBER	
08	TYPE OF ACCOUNT	CURRENT A/C / OD / CASH CREDIT
09	BENEFICIARY'S NAME	
10	IFSC CODE OF THE BRANCH	
11	EMAIL ID	
12	TELEPHONE/MOBILE NO.	

CERTIFICATE

I / We hereby agree to receive the payments due from BHARAT HEAVY ELECTRICALS LIMITED by the National Electronic Funds Transfer and / or RTGS Transfer mode by credit to my / our above mentioned Bank Account. I / We also agree that payments made to the above mentioned Account is a valid discharge of the liability of Bharat Heavy Electricals Limited. I / We also agree to bear the applicable Bank Charges for the above mode of transfer. **Original cheque leaf/cancelled cheque leaf of the above account is sent herewith.**

AUTHORISED SIGNATORY WITH NAME SEAL

Banker's Certification

We confirm that we are enabled for receiving RTGS and NEFT credits and we further confirm that the account number of _____ (name of account holder), the signature of the authorized signatory and the MICR and IFSC codes of our Branch mentioned above are correct.

PLACE:

(Manager / Officer's)

DATE:

Signature Under Bank stamp and Name Seal
with Membership No :

(Telephone / Mobile No)

Forwarded to Accounts Dept.

We confirm the above details are verified with the records available with us.

Signature of the BHEL Executive with Name Seal (Operating the Contract/Services)

Place

Date

Signature of the Bidder
(NAME & ADDRESS WITH SEAL)



Bharat Heavy Electricals Limited

(A Govt. of India Undertaking)

Power Plant Piping Unit, Thirumayam – 622 507, Tamil Nadu

Tender Notice

Annexure-X

PROFORMA OF BANK GUARANTEE FOR EARNEST MONEY DEPOSIT (EMD)
(On non-Judicial paper of appropriate value)

Bank Guarantee No.....

Date.....

To

(Employer's Name and Address)

.....

Dear Sirs,

In accordance with the terms and conditions of Invitation for Bids/Notice Inviting Tender

No.....**1**(Tender Conditions), M/s. having its registered office at**2** (hereinafter referred to as the 'Tenderer'), is submitting its bid for the work of.....**3** invited by**4**.(name of the Employer) through its Unit at

The Tender Conditions provide that the Tenderer shall pay a sum of Rs as Earnest Money Deposit in the form therein mentioned. The form of payment of Earnest Money Deposit includes Bank Guarantee executed by a Scheduled Bank.

In lieu of the stipulations contained in the aforesaid Tender Conditions that an irrevocable and unconditional Bank Guarantee against Earnest Money Deposit for an amount of**5** is required to be submitted by the Tenderer as a condition precedent for participation in the said Tender and the Tenderer having approached us for giving the said Guarantee,

We, the[Name & address of the Bank]

.....having our Registered Office at

.....(hereinafter referred to as the Bank) being the Guarantor under this

Guarantee, hereby irrevocably and unconditionally undertake to forthwith and immediately pay to the Employer without any demur, merely on your first demand any sum or sums of Rs..... **5**

.....(in words Rupees.....) without any reservation, protest, and recourse and without the beneficiary needing to prove or demonstrate reasons for its such demand.

Any such demand made on the Bank shall be conclusive as regards the amount due and payable by the Bank under this guarantee. However, our liability under this guarantee shall be restricted to an amount not exceeding Rs.

.....

We undertake to pay to the Employer any money so demanded notwithstanding any dispute or disputes raised by the Vendor/Contractor/Vendors in any suit or proceeding pending before any Court or Tribunal, Arbitrator or any other authority, our liability under this present being absolute and unequivocal.

Place

Date

Signature of the Bidder

(NAME & ADDRESS WITH SEAL)



Bharat Heavy Electricals Limited

(A Govt. of India Undertaking)

Power Plant Piping Unit, Thirumayam – 622 507, Tamil Nadu

Tender Notice

The payment so made by us under this Guarantee shall be a valid discharge of our liability for payment hereunder and the Tenderer shall have no claim against us for making such payment.

We Bank further agree that the Employer shall have the fullest liberty without our consent and without affecting in any manner our obligations hereunder to vary any of the terms and conditions of the said Tender or to extend the time of submission of from time to time or to postpone for any time or from time to time any of the powers exercisable by the Employer against the said Tenderer and we shall not be relieved from our liability by reason of any such variation, or extension being granted to the said Tenderer or for any forbearance, act or omission on the part of the Employer or any indulgence by the Employer to the said Tenderer or by any such matter or thing whatsoever which under the law relating to sureties would but for this provision have effect of so relieving us.

The Bank also agrees that the Employer at its option shall be entitled to enforce this Guarantee against the Bank as a principal debtor, in the first instance without proceeding against the Tenderer and notwithstanding any security or other guarantee that the Employer may have in relation to the Tenderer's liabilities.

This Guarantee shall be irrevocable and shall remain in force upto and including.....6 and shall be extended from time to time for such period as may be desired by the Employer.

This Guarantee shall not be determined or affected by liquidation or winding up, dissolution or change of constitution or insolvency of the Tenderer but shall in all respects and for all purposes be binding and operative until payment of all money payable to the Employer in terms hereof. However, unless a demand or claim under this Guarantee is made on us in writing on or before the 7 we shall be discharged from all liabilities under this Guarantee.

We, Bank lastly undertake not to revoke this guarantee during its currency except with the previous consent of the Employer in writing.

Notwithstanding anything to the contrary contained hereinabove:

- a) The liability of the Bank under this Guarantee shall not exceed.....5.....
- b) This Guarantee shall be valid up to6
- c) Unless the Bank is served a written claim or demand on or before _____7 all rights under this guarantee shall be forfeited and the Bank shall be relieved and discharged from all liabilities under this guarantee irrespective of whether or not the original bank guarantee is returned to the Bank.
- d) **Any claim or dispute arising under the terms of this document shall be enforced or settled only in the courts in PUDUKKOTTAI located in TAMILNADU**

We, _____ Bank, have power to issue this Guarantee under law and the undersigned as a duly authorized person has full powers to sign this Guarantee on behalf of the Bank.

For and on behalf of

(Name of the Bank)

Date.....

Place of Issue.....

Place

Date

Signature of the Bidder
(NAME & ADDRESS WITH SEAL)



Bharat Heavy Electricals Limited

(A Govt. of India Undertaking)

Power Plant Piping Unit, Thirumayam – 622 507, Tamil Nadu

Tender Notice

1 Details of the Invitation to Bid/Notice Inviting Tender

2 Name and Address of the Tenderer

3 Details of the Work

4 Name of the Employer

5 BG Amount in words and Figures

6 Validity Date

7 Date of Expiry of Claim Period

Notes:

1. The Bank Guarantee shall be valid for at least six months.
2. The BG should be on Non-Judicial Stamp paper/e-stamp paper of appropriate value as per Stamp Act prevailing in the State(s) where the BG is submitted or is to be acted upon or the rate prevailing in the State where the BG was executed, whichever is higher. The Stamp Paper/e-stamp paper shall be purchased in the name of Contractor/subcontractor /vendor/ Bank issuing the guarantee.

4. In Case of Bank Guarantees submitted by Foreign Vendors.

a. From Nationalized/Public Sector / Private Sector/ Foreign Banks (BG issued by Branches in India) can be accepted subject to the condition that the Bank Guarantee should be enforceable in the town/city or at nearest branch where the Unit is located i.e. Demand can be presented at the Branch located in the town/city or at nearest branch where the Unit is located.

b. From Foreign Banks (wherein Foreign Vendors intend to provide BG from local branch of the Vendor Country's Bank)

b.1 In such cases, in the Tender Enquiry/ Contract itself, it may be clearly specified that Bank Guarantee issued by **any of the Consortium Banks only** will be accepted by BHEL. As such, Foreign Vendor needs to make necessary arrangements for issuance of Counter- Guarantee by Foreign Bank in favour of the Indian Bank's (BHEL's Consortium

Bank) branch in India. It is advisable that all charges for issuance of Bank Guarantee/ counter- Guarantee should be borne by the Foreign Vendor. The tender stipulation should clearly specify these requirements.

b.2 In case, Foreign Vendors intend to provide BG from Overseas Branch of our Consortium Bank (e.g. if a BG is to be issued by SBI Frankfurt), the same is acceptable. However, the procedure at **sl.no. b.1** will required to be followed.

b.3 The BG issued may preferably be subject to Uniform Rules for Demand Guarantees (URDG) 758 (as amended from time to time). The BG Format provided to them should clearly specify the same.

Place
Date

Signature of the Bidder
(NAME & ADDRESS WITH SEAL)



Bharat Heavy Electricals Limited

(A Govt. of India Undertaking)

Power Plant Piping Unit, Thirumayam – 622 507, Tamil Nadu

Tender Notice

Annexure-Y

PROFORMA OF BANK GUARANTEE (in lieu of SECURITY DEPOSIT)

(To be taken on Non-Judicial Stamp paper/e-stamp paper as per Stamp Act prevailing in the State)

Bank Guarantee No:

Date:

To

Bharat Heavy Electricals Limited

High Pressure Boiler Plant, Tiruchirappalli – 620014 / Power Plant Piping Unit, Thirumayam – 622507

Dear Sirs,

- a) In consideration of Bharat Heavy Electricals Limited¹ (hereinafter referred to as the 'Employer' which expression shall unless repugnant to the context or meaning thereof, include its successors and permitted assigns) incorporated under the Companies Act, 1956 and having its registered office at "BHEL House" SIRI Fort, New Delhi – 110 049), through its Unit **High Pressure Boiler Plant, BHEL, Tiruchirappalli – 620014 / Power Plant Piping Unit, Thirumayam – 622507** having awarded to(**NAME OF THE VENDOR / CONTRACTOR / SUPPLIER / VENDOR CODE**) with its registered office at (**NAME AND ADDRESS OF THE VENDOR / CONTRACTOR / SUPPLIER**) hereinafter referred to as the 'Vendor / Contractor / Supplier', which expression shall unless repugnant to the context or meaning thereof, include its successors and permitted assigns), a contract Ref No(**DETAILS ABOUT THE NOTICE OF AWARD/CONTRACT REFERENCE**).....dated valued at Rs..... (**CONTRACT VALUE**) Rupees -----)/ FC.....(in words.....) for(**PROJECT/SUPPLY DETAILS**) (hereinafter called the 'Contract') and the Vendor / Contractor / Supplier having agreed to provide a Contract Performance Bank Guarantee, equivalent to 5 % (Five Percent) of the said value of the Contract to the Employer for the faithful performance of the Contract,
- b) We,, (hereinafter referred to as the Bank), having registered/Head office at and inter alia a branch at being the Guarantor under this Guarantee, hereby, irrevocably and unconditionally undertake to forthwith and immediately pay to the Employer any sum or sums upto a maximum amount of Rs ----- (**BG AMOUNT IN FIGURES AND WORDS**) (Rupees -----) without any demur, immediately on first demand from the Employer and without any reservation, protest, and recourse and without the Employer needing to prove or demonstrate reasons for its such demand.

Place
Date

Signature of the Bidder
(NAME & ADDRESS WITH SEAL)



Bharat Heavy Electricals Limited

(A Govt. of India Undertaking)

Power Plant Piping Unit, Thirumayam – 622 507, Tamil Nadu

Tender Notice

- c) Any such demand made on the Bank shall be conclusive as regards the amount due and payable by the Bank under this guarantee. However, our liability under this guarantee shall be restricted to an amount not exceeding Rs. _____. (*BG AMOUNT IN FIGURES AND WORDS*)
- d) We undertake to pay to the Employer any money so demanded notwithstanding any dispute or disputes raised by the Vendor / Contractor / Supplier in any suit or proceeding pending before any Court or Tribunal, Arbitrator or any other authority, our liability under this present being absolute and unequivocal.
- e) The payment so made by us under this Guarantee shall be a valid discharge of our liability for payment thereunder and the Vendor / Contractor / Supplier shall have no claim against us for making such payment.
- f) We thebank further agree that the guarantee herein contained shall remain in full force and effect during the period that would be taken for the performance of the said Contract/satisfactory completion of the performance guarantee period as per the terms of the Contract and that it shall continue to be enforceable till all the dues of the Employer under or by virtue of the said Contract have been fully paid and its claims satisfied or discharged.
- g) We.....BANK further agree with the Employer that the Employer shall have the fullest liberty without our consent and without affecting in any manner our obligations hereunder to vary any of the terms and conditions of the said Contract or to extend time of performance by the said Vendor / Contractor / Supplier from time to time or to postpone for any time or from time to time any of the powers exercisable by the Employer against the said Vendor / Contractor / Supplier and to forbear or enforce any of the terms and conditions relating to the said Contract and we shall not be relieved from our liability by reason of any such variation, or extension being granted to the said Vendor / Contractor / Supplier or for any forbearance, act or omission on the part of the Employer or any indulgence by the Employer to the said Vendor / Contractor / Supplier or by any such matter or thing whatsoever which under the law relating to sureties would but for this provision have effect of so relieving us.
- h) The Bank also agrees that the Employer at its option shall be entitled to enforce this Guarantee against the Bank as a principal debtor, in the first instance without proceeding against the Vendor / Contractor / Supplier and notwithstanding any security or other guarantee that the Employer may have in relation to the Vendor / Contractor / Supplier's liabilities.
- i) This Guarantee shall remain in force upto and including..... (*SIX MONTHS BEYOND THE CLOSING DATE OF CONTRACT*) and shall be extended from time to time for such period as may be desired by Employer.
- j) This Guarantee shall not be determined or affected by liquidation or winding up, dissolution or change of constitution or insolvency of the Vendor / Contractor / Supplier but shall in all respects and for all purposes be binding and operative until payment of all money payable to the Employer in terms thereof.

Place
Date

Signature of the Bidder
(NAME & ADDRESS WITH SEAL)



Bharat Heavy Electricals Limited

(A Govt. of India Undertaking)

Power Plant Piping Unit, Thirumayam – 622 507, Tamil Nadu

Tender Notice

- k) Unless a demand or claim under this guarantee is made on us in writing on or before the *(SIX MONTHS BEYOND THE CLOSING DATE OF CONTRACT)* we shall be discharged from all liabilities under this guarantee thereafter.
- l) Any claim or dispute arising under the terms of this document shall only be enforced or settled in the Courts at Tiruchirappalli.
- m) We..... BANK lastly undertake not to revoke this guarantee during its currency except with the previous consent of the Employer in writing.
Notwithstanding anything to the contrary contained hereinabove:
- a. The liability of the Bank under this Guarantee shall not exceed..... *(BG AMOUNT IN FIGURES AND WORDS)*
 - b. This Guarantee shall be valid up to *(SIX MONTHS BEYOND THE CLOSING DATE OF CONTRACT)*
 - c. Unless the Bank is served a written claim or demand on or before *(SIX MONTHS BEYOND THE CLOSING DATE OF CONTRACT)* all rights under this guarantee shall be forfeited and the Bank shall be relieved and discharged from all liabilities under this guarantee irrespective of whether or not the original bank guarantee is returned to the Bank.
- n) We, _____ Bank, have power to issue this Guarantee under law and the undersigned as a duly authorized person has full powers to sign this Guarantee on behalf of the Bank.

For and on behalf of
(Name of the Bank)

Dated.....

Place of Issue.....

BANK IFSC AND MICR CODE BANK

EMAIL ID:

BANK PHONE NO:

AUTHORISED SIGNATORIES CELL PHONE NO:

BANK FAX NO:

Place
Date

Signature of the Bidder
(NAME & ADDRESS WITH SEAL)



Bharat Heavy Electricals Limited

(A Govt. of India Undertaking)

Power Plant Piping Unit, Thirumayam – 622 507, Tamil Nadu

Tender Notice

LIST OF CONSORTIUM BANKS IN INDIA

List of Consortium Bank	
Sl. No.	Name of the Bank
1.	State Bank of India
2.	Canara Bank
3.	Axis Bank
4.	Bank of Baroda
5.	Central bank
6.	Citi Bank N.A
7.	Deutsche Bank
8.	Exim Bank
9.	Federal Bank Limited
10.	HDFC Bank Limited
11.	Hong Kong and Shanghai Banking Corporation Limited
12.	Indian Bank
13.	ICICI Bank Limited
14.	IDBI Bank Limited
15.	IndusInd Bank Limited
16.	Indian Overseas Bank
17.	Kotak Mahindra Bank Limited
18.	Punjab National Bank
19.	RBL Bank Ltd.
20.	Standard Chartered Bank
21.	Union Bank of India
22.	Yes Bank Limited

- (1) It should be typed in the Rs. 100 value of stamp paper.
- (2) It should be signed by TWO bank officials with Rubber stamp containing names & employee numbers of bank officials.
- (3) It should be submitted with bank covering letter with sign and seal of the bank official.
- (4) Bank Guarantee issued by any of the Consortium Banks only will be accepted by BHEL.

Place
Date

Signature of the Bidder
(NAME & ADDRESS WITH SEAL)



Bharat Heavy Electricals Limited

(A Govt. of India Undertaking)

Power Plant Piping Unit, Thirumayam – 622 507, Tamil Nadu

Tender Notice

GENERAL DETAILS:

(To be filled by Bidder)

Tender Ref: PPPU: WC: 22: 030

Date: 27.12.2022

01	Name and full address of the Company / Firm	
02	Name of contact Person with Designation	
03	Contact Details:	
	Landline No.	
	Mobile No.	
	email ID:	
04	Local Office Address with Contact person, Phone No., Mobile No., email ID, Fax No. (If any)	
05	Vendor code allotted by BHEL if any	
06	List of BHEL units in which vendor has executed any type of contract previously or is currently executing any type of contract	

Place
Date

Signature of the Bidder
(NAME & ADDRESS WITH SEAL)



Bharat Heavy Electricals Limited
(A Govt. of India Undertaking)
Power Plant Piping Unit, Thirumayam – 622 507, Tamil Nadu

Tender Notice

TECHNO COMMERCIAL BID

(To be filled by bidder)

ELIGIBILITY CRITERIA DETAILS:

ANNEXURE - A

SI. NO	ELIGIBILITY CRITERIA	BIDDER'S RESPONSE
1.	EMD PAYMENT (Rs. 30,000/-)	(Proof to be attached in EPS)
2.	The contractor should have an Income Tax Registration (PAN). (Details of self- attested copy to be furnished) (Please mention Page No ----- in which this proof is attached in uploaded tender document)	PAN No. _____ (Proof to be attached in EPS)
3.	Goods & Service Tax (GST) registration / Application Reference Number. (copy of registration details indicating GSTIN/ARN to be submitted along with offer. (If any specific exemption is available, a declaration with due supporting documents need to be furnished for considering the offer). (Please mention Page No ----- in which this proof is attached in uploaded tender document)	Regn. No. – _____ (Proof to be attached in EPS)
4.	Company Status (Proprietorship/ Partnership Firm/LLP/One-person Company/Private Limited Company/Public Limited Company/Trust/Society) (Proof to be attached) (Please mention Page No ----- in which this proof is attached in uploaded tender document)	Company status: (Proof to be attached in EPS)
5.	The bidder should furnish details of successfully executing similar works in the last 7 years as on the date of tender opening as follows: a. At least Three similar works each not less than Rs. 6 Lakhs or b. Two similar works each not less than Rs.7.50 Lakhs or c. At least One similar work not less than Rs.12.0 Lakhs. Similar Work means "Any kinds of Civil Construction/ Maintenance works including excavation, masonry, RCC works, plumbing, carpentry, steel, glazing, roads etc.," Proof of Work Order / Purchase Order/ Experience certificate should be attached. Proof of experience from any organization other than BHEL Trichy / Thirumayam to be supported by TDS (Tax Deducted at Source) certificate issued	Proof to be uploaded in EPS

Place
Date

Signature of the Bidder
(NAME & ADDRESS WITH SEAL)



Bharat Heavy Electricals Limited

(A Govt. of India Undertaking)

Power Plant Piping Unit, Thirumayam – 622 507, Tamil Nadu

Tender Notice

	<i>by the organizations OR Form 26 AS or bank statement for transaction of payment.</i> <i>(Please mention Page No ----- in which this proof is attached in uploaded tender document)</i>	
6.	<i>Duly signed certificate of compliance in bidder's letter head shall be attached. (Annexure III)</i> <i>(Please mention Page No ----- in which this proof is attached in uploaded tender document)</i>	<i>("Certificate of compliance" to be attached in EPS which should be in bidder's letterhead)</i>
7.	<i>Duly signed Local Content Declaration in bidder's letter head shall be attached (Annexure II)</i> <i>(Please mention Page No ----- in which this proof is attached in uploaded tender document)</i>	<i>Duly signed and stamped to be uploaded</i>
8.	<i>Applicable GST rate</i> <i>(Please mention Page No ----- in which % is mentioned in uploaded tender document)</i>	_____ %

OTHER INFORMATION / DETAILS:

SI. NO	CRITERIA	BIDDER'S RESPONSE
1.	<i>MSE Vendor status</i> <i>(Self-attested copies of Udyam Registration Certificate to be submitted)</i> <i>(Please mention Page No ----- in which this proof is attached in uploaded tender document)</i>	<i>(Proof to be attached in EPS)</i>
2.	<i>General Details shall be attached.</i> <i>(Please mention Page No ----- in which this proof is attached in uploaded tender document)</i>	<i>("General Details" should be Submitted in EPS)</i>

NOTE:

- 1) All Pages of tender documents must be signed & sealed (digitally on 1st page or manually in each page) by the bidder before uploading in EPS portal. This shall ensure that the bidder has agreed to all conditions of tender document.**
- 2) All supporting documents pertaining to the above Criteria (Copies of UDYAM certificate, experience proof, etc.) must be signed & sealed (digitally on 1st page or manually in each page) by the bidder before uploading in EPS portal.**

Place
Date

Signature of the Bidder
(NAME & ADDRESS WITH SEAL)



Bharat Heavy Electricals Limited

(A Govt. of India Undertaking)

Power Plant Piping Unit, Thirumayam – 622 507, Tamil Nadu

Tender Notice

ANNEXURE – I

E-PAYMENTS

- I. This annexure to the techno-commercial bid explains how to make e-payments to BHEL- Tiruchirappalli through SBI e-collect.
- II. Vendors (EMD and SD Payments payable by others) can utilise this facility.
- III. Payments can be made using Internet Banking, Debit Cards/Credit Cards etc.
- IV. SBI Charges a minimum amount (Service Charge) for every transaction. This may vary according to the MODE selected.

STEP BY STEP PROCEDURE:

Login to <https://www.onlinesbi.com>

1. Select State Bank Collect available on the top (pre login page)
2. Accept the terms and conditions and click “PROCEED”
3. Select State “TAMILNADU “and Institution type “INDUSTRY “.
4. Select “BHEL TRICHY under “INDUSTRY”.
5. In the next page, Select APPROPRIATE category, fill details correctly & click “SUBMIT”.
6. If all details entered are correctly populated, click “CONFIRM “to proceed.
7. Make payment as per your convenience. (Options available are payment of fees through SBI Net Banking, State Bank ATM cum Debit Cards / Other Bank Debit / Credit Cards and through SBI Branches).
8. SAVE & Keep the copy of receipt for future reference.

HOW TO TAKE RECEIPT FOR A PAYMENT MADE, EVEN ON A LATER DATE:

(PLEASE CHECK THE STATUS BEFORE MAKING PAYMENT SECOND TIME)

1. Login to www.onlinesbi.com
2. Select State Bank Collect available on the top (pre login page)
3. Accept the terms and conditions and click “PROCEED”
4. Select “PAYMENT HISTORY “option available on the left side of screen.
5. Using two options as mentioned below, you can get the receipt:
 - a. Type the same Date of Birth, Mobile Number which you have entered at the time of making payment through SB collect. Select the date range and submit.
6. If you know the payment reference number, then enter the Reference number (DU...) along with anyone information (Date of Birth / Mobile number, which you have entered at the time of making payment). Select the date range and submit.
7. In the next page, take print out of receipt.

Place
Date

Signature of the Bidder
(NAME & ADDRESS WITH SEAL)



Bharat Heavy Electricals Limited

(A Govt. of India Undertaking)

Power Plant Piping Unit, Thirumayam – 622 507, Tamil Nadu

Tender Notice

ANNEXURE II (Local Content)

(TO BE SUBMITTED ON BIDDER'S LETTER HEAD)

Tender Ref No.: PPPU: WC: 22: 030

Dt. 27.12.2022

Self-Declaration

Enquiry No.	
Enquiry Date	

In line with Government public procurement order Number P 45021/2/2017 B.E II dated 15.06.2017, and further modified order dt. 28.05.2018 & 04.06.2020.

I / We hereby declare that I / We are a "Local Supplier" meeting the requirement of minimum local content (.....%) defined in the above government notification for the goods/Services against above mentioned enquiry Number. Details of location at which local value addition/ Service will be made is as follows:

Address	
District	
State	
Country	
PIN Code	

We also understand that the false declarations will be considered as breach of Integrity and liable for action.

For Company Name:

Seal:

Signature:

Place
Date

Signature of the Bidder
(NAME & ADDRESS WITH SEAL)



Bharat Heavy Electricals Limited

(A Govt. of India Undertaking)

Power Plant Piping Unit, Thirumayam – 622 507, Tamil Nadu

Tender Notice

Annexure III -CERTIFICATE OF COMPLIANCE

(To be submitted in bidder's letter head)

Tender Ref No: PPPU: WC: 22: 030

Date: 27.12.2022

To

DGM / Contracts, MS & DTG,
Power Plant Piping Unit,
BHEL – Thirumayam-622 507.

Sir,

We have carefully read the tender specifications connected with the above tender and have understood the technical requirements and conditions to the above tender which consists of

1. Eligibility criteria
2. Scope of work
3. Commercial Terms & Conditions
4. Conditions Related to The Welfare of Labors
5. General Terms and Conditions.
6. Technical Bid
7. RTGS/NEFT Format
8. General Details
9. All Annexures

I/We M/s.

have read and clearly understood all the Terms and conditions in Tender Schedule of and accordingly accept the same without any deviation what so ever.

- I/We declares that I/We will not enter into any illegal or undisclosed agreement or understanding, whether formal or informal with other Bidder(s). This applies in particular to prices, specifications, certifications, subsidiary contracts, submission or non-submission of bids or any other actions to restrict competitiveness or to introduce cartelization in the bidding process. In case I/We found having indulged in above activities, suitable action shall be taken by BHEL as per extant policies/ guidelines.
- I/ We unconditionally agree to all the tender conditions and no new conditions are imposed by us in the technical / price bid. I understand in the event of imposing any condition in the technical / price bid, such condition would be ignored by BHEL and only the prices will be considered for the purpose of evaluation”
- I/ We confirm that none of our group concern or affiliates etc., appears on the list of banned firms / companies by BHEL (list available on www.bhel.com) nor any of the Director / Partner / proprietor of bidder / such group concern or affiliate etc. are involved with such company.

Place
Date

Signature of the Bidder
(NAME & ADDRESS WITH SEAL)



Bharat Heavy Electricals Limited

(A Govt. of India Undertaking)

Power Plant Piping Unit, Thirumayam – 622 507, Tamil Nadu

Tender Notice

- I/ We also declare that, we have not been suspended or black listed or issued with Show Cause Notice by BHEL- Trichy or any other BHEL Unit or any PSU/ Government organization.
- I/We also declare that there is no case or charge under investigation, enquiry or trial against me/us or any conviction in a court of law nor have been banned by any organizations /Govt. on any grounds.
- I/ We confirm that other than us, none of our group concerns or affiliates etc. are participating in the tender either directly or indirectly through any other agency under same proprietor / common director(s) / common partner(s).
- I/ We confirm that if any of the above statement / information furnished by us in this tender is found to be false/ fake at any stage of tender evaluation or during execution of contract, BHEL will have the right to initiate appropriate action including legal proceeds / termination of contract, recovery of damages, penalties etc. as deemed fit.
- If the contract is awarded to us the prices shall be kept firm till the completion of contract.
- If the contract is awarded to us, I /We confirm that security deposit (SD) required of execution of the contract will be submitted on or before commencement date as indicated in LOI. In case of delay in submission of performance security (SD), enhanced SD which would include interest (SBI rate+6%) for the delayed period, shall be submitted by bidder. Further, if performance security (SD) is not submitted till such time the first bill becomes due, the amount of performance security due shall be recovered as per terms defined in NIT/Contract, from the bills along with due interest.

Place
Date

Signature of the Bidder
(NAME & ADDRESS WITH SEAL)

ANNEXURE - V

GENERAL CONDITIONS OF CONTRACT FOR LUMP SUM, ITEM RATES AND PERCENTAGE CONTRACT

CONTENTS

Condition No	Description
CHAPTER - I	
1	DEFINITIONS
CHAPTER - II	
SCOPE OF CONTRACT	
2	HEADING TO THE CONTRACT
3	CONTRACT DOCUMENTS
4	WORKS TO BE CARRIED OUT
5	PROVISIONAL ITEMS
6	DEVIATIONS
7	TIME
8	STORES & MATERIALS
9	DELAY & EXTENSION OF TIME
10	PATENT RIGHTS
11	OCTROI AND OTHER DUTIES
12	ROYALTIES
13	PLANT & EQUIPMENT
14	ASSIGNMENT OR TRANSFER OF CONTRACT
	a) SUB-CONTRACT
15	COMPLIANCE TO REGULATIONS AND BYE-LAWS

CHAPTER - III

PERFORMANCE OF THE CONTRACT

16	SECURITY DEPOSIT
17	ORDERS UNDER THE CONTRACT
18	ADMISSION TO SITE
19	CONTRACTOR'S SUPERVISION
20	LABOR
21	WATER
22	TEMPORARY WORKSHOPS, STORES ETC.
23	STORES & MATERIALS ON SITE
24	TOOLS AND PLANTS ON SITE
25	STATEMENT OF HIRE CHARGES
26	PRECAUTIONS AGAINST RISKS
27	NOTICE & FEES
28	SETTING OUT OF THE WORKS & PROTECTION & MAINTAINING SIGNALS AND WORKS
29	SITE DRAINAGE
30	EXCAVATIONS, RELICS ETC.
31	FOUNDATIONS
32	COVERING-IN WORKS
33	APPROVAL OF WORKS BY STAGES
34	EXECUTION OF WORKS
35	DAY WORKS
36	INSPECTION OF THE WORKS
37	RESPONSIBILITY FOR BUILDING
38	INSURANCE OF WORKS
39	DAMAGE AND LOSS TO PRIVATE PROPERTY & INJURY TO WOKMEN
40	COMPLETION
41	COMPENSATION FOR DELAY
42	LAWS GOVERNING THE CONTRACT
43	CANCELLATION OF CONTRACT FOR CORRUPT ACT
44	CANCELLATION OF CONTRACT FOR INSOLVENCY, ASSIGNMENT OR SUB LETTING OF CONTRACT

45	CANCELLATION OF CONTRACT FOR DEFAULT
46	TERMINATION OF CONTRACT FOR DEATH
47	SPECIAL POWERS OF DETERMINATION
48	FAIR WAGE

CHAPTER – IV

VALUATION AND PAYMENT

49	RECORDS & MEASUREMENTS
50	VALUATION OF DEVIATIONS
51	REIMBURSEMENT/ REFUND ON VARIATION IN PRICE
52	ADVANCES ON ACCOUNT
53	FINAL BILL
54	PAYMENT OF BILLS
55	RECOVERY FROM CONTRACTOR
56	POST TECHNICAL AUDIT OF WORKS AND BILLS
57	REFUND OF SECURITY DEPOSIT
58	ARBITRATION

CHAPTER- I

1. DEFINITIONS

In these General Conditions of Contract, the following terms shall have the meaning hereby assigned to them except where the context otherwise requires: -

- a) The “CONTRACT” means the documents forming the tender and acceptance thereof, together with all documents referred to therein including General and Special Conditions of Contract, and/ or General Summary attached to form the tender, the Bharat Heavy Electricals Limited, Schedule of Rates as amended and in force the Specifications and the Drawings. All these documents as applicable taken together shall be deemed to form one Contract and shall be complementary to one another.
- b) The “TENDER DOCUMENTS” means the form of Tender the applicable Schedules and/ or General Summary, General and Special Conditions of Contract and the Specification and/ or Drawings as given to Contractors.
- c) The “WORK” means the work described in the tender documents in individual work orders and/or accompanying Drawings and Specifications as may be issued from time to time to the Contractor by the Engineer–in– charge within the powers conferred upon them, including all modified or additional works and obligations to be carried out either at the site or at any Factory Workshop or other place as required for the performance of the Contract.
- d) The “SITE” means the lands and/or other places on, in into or through which the work is to be executed under the Contract or any adjacent land, path or street which may be allotted to or used for the purpose of carrying out the contract.
- e) The “CONTRACTOR” means the individual, firm or Company, whether incorporated or not undertaking the work and shall include the legal personal representatives of such individuals or the persons composing the firm or Company, or the successors of the firm or Company and the permitted assigns of such individual or firm or Company.
- f) The “Engineer–in–charge” means the Engineer who is in charge for the works referred.

CHAPTER- II

SCOPE OF CONTRACT

2. Heading to the Contract:

The heading to these conditions shall not affect the interpretation thereof.

3. Contract Documents

The Contractor shall keep one copy of all the Drawings and the Specifications at the site and the Engineer-in-charge or his representative shall have access to them at all reasonable times.

None of these documents shall be used by the contractor for any purpose other than that of this contract.

The Contractor shall take necessary steps to ensure that all persons employed on any work in connection with this contract have noticed that the Indian Official Secrets Act 1923 (XIX of 1923) applies to them and shall continue so to apply even after the execution of such works under the contract.

4. Works to be Carried Out

The Contract shall, except as provided under BHEL free issue material, include all labor, material, tools, plants equipment and transport which may be required in preparation for, and in the entire execution and full completion of the work. The tender shall be deemed to have been prepared in accordance with good practice and recognized principles and unless otherwise stated, the descriptions given therein shall be held to include waste on material carriage and cartage, lead, return of empties, hoisting, setting, fitting in position and all other labor necessary in and for the entire execution and full completion aforesaid. Any error in description or quantity or any omission there from shall not vitiate the Contract or release the Contractor from the execution of the whole or any part of the work comprised therein according to the Drawings and Specifications, or from any of his obligations under the Contract. The insertion of the name of any firm of suppliers in the Tender Documents is for the purpose of obtaining a particular class or quality of material or workmanship but the articles or material specified may be obtained from any other firm subject to prior written approval of the Engineer – in – charge.

In the case of any discrepancy the Accepting Officer shall be the sole deciding authority as to which shall prevail and his decision shall be final and conclusive. If neither Drawings nor Specifications contain any mention of minor details of construction, which in the opinion of the Accepting Officer whose decision shall be final and conclusive, are reasonable and obviously and fairly intended for the satisfactory completion of the work, such details shall be provided by the Contractor without any extra cost as if they were specially mentioned and shall be deemed to be included in the contract.

The contractor will be deemed to have satisfied himself as to the nature of the site, local facilities of access and all matters affecting the execution and completion of the work. No extra charges consequent on any misunderstanding in these respects or otherwise will be allowed.

5. Provisional Items

The full amount of provisional lump sums and the value annexed to each provisional item inserted in the tender documents shall be deducted from the contract sum and the value of work ordered and executed thereunder shall be ascertained by measurement or valuation as for deviations.

No work under these items is to be begun without instructions in writing from the Engineer-in-charge.

The extent of quantities or items described as “Provisional” shall not be held to guarantee or limit the amount and description of the work to be executed by the contractor either in respect of the items concerned or the work as a whole.

No addition or deduction shall be made by the Contractor to the amount of the provisional lump sums as included in the tender documents.

6. Deviations

The contractor shall not make any alteration in addition to or omission from the work as described in the tender documents except in pursuance of the written instructions of the Engineer-in-charge. No such deviation from the work described in the tender documents shall be valid unless the same has been specifically confirmed and accepted by the Accepting Officer in writing and incorporated in the contract.

The Accepting Officer may deviate either by way of addition or deduction, from the work so described, provided that the contract sum be not thereby varied on the whole by more than the percentage set out in the tender documents. The value of all addition and deductions will be added to, or deducted from the contract sum. Whenever the Accepting Officer intends to exercise such a right, his intention shall specify the deviations which are to be made, the lump sum assessment or the proposed basis of payment, the extra time allowed, if any, and the date for completion of the entire contract.

Any objection by the Contractor to any matter concerning the order shall be notified by him in writing to the Engineer-in-charge within **Seven days** from the date of such order, but under no circumstances shall the work be stopped (unless so ordered by the Engineer-in-charge) owing to differences or controversy that may arise from such an objection. In the absence of such a notification of objection by the contractor, he will be deemed to have accepted the order and the conditions stated therein. In the event of the contractor failing to agree with the Engineer-in-charge regarding the terms of the proposed deviation, the objection shall be referred to the Project Manager whose decision shall be final conclusive and binding on the Contractor.

7. Time

Time is the essence of the contract and is specified in the tender document or in each individual Work Order.

As soon as possible after the contract is let or any substantial Work Order is placed and before work under is to begin, the Engineer-in-charge and the Contractor shall agree to a Time and

Progress Chart. The Chart shall be prepared in direct relation to the time stated in the Tender Documents or the Work Order for the completion of the individual items thereof and/ the contract or order as a whole. It shall indicate the forecast of the dates for the commencement of the various trade processes or sequences of the work, and shall be amended as may be required by agreement between the Engineer-in-charge and the Contractor within the limitation of the time imposed in the Tender Documents or Order

In the absence of any specific Time and Progress chart to be agreed to between the Contractor and the Engineer-in-charge, the contractor shall ensure and maintain uninterrupted progress of the work such that the entire work shall be completed within the time imposed in the Tender Documents or Order and that the proportion of work completed upto any time in relation to the entire work to be under the Contractor Order shall not be less than the proportion that the time elapsed bears to the total time of completion provided in the Tender Documents or Work Order/ Sub Work Order.

The contractor shall suspend the execution of the work, or any part or parts thereof whenever called upon in writing by the Engineer-in-charge to do so, and shall not resume work thereon until so directed in writing by the Engineer-in-charge. The Contractor will be allowed an extension of time for completion not less than the period of suspension. However, no other claim in this respect for compensation or otherwise however will be admitted. Provided the cause for suspension is not attributable to any default on the contractor's part to proceed with or fulfill the contractual obligations. This may also be extended to allow for alteration of work made by the deviation order.

8. Stores and Material

The Contractor shall, at his own cost and expense, provide all material required for the works, other than those which are to be supplied by Bharat Heavy Electricals Limited. All material to be supplied by the Contractor shall be of the best kind as described in the specifications and the Contractor shall, if requested by the Engineer-in-charge, furnish proof to the satisfaction of the Engineer-in-charge, that the material so comply with the specifications.

The contractor shall, at his own expense and without delay, supply samples of material proposed to be used in the execution of the work for approval of the Engineer-in-charge, who may reject the material not corresponding either in quality or character to the approved samples.

In the case of provision of material from stores, the Contractor shall bear the cost of loading, transporting to site, unloading, storing under cover as required assembling and jointing the several parts together as necessary and incorporating or fixing these stores material in the work, including all preparatory work of whatever description as may be required, and of closing, preparing, loading and returning empty cases or containers to the place of issue without any extra charges.

9. Delay and Extension of Time:

If, in the opinion of Engineer-in-charge the work is delayed:

- i) by reason of abnormally bad weather, OR
- ii) by reason of serious loss or damage by fire, OR
- iii) by reason of Civil commotion, local combination of workmen strikes or lockout, affecting any of the trades employed on the work OR.
- iv) by delay on the part of the agency or tradesman engaged by BHEL in executing work not forming part of this contract, OR
- v) by reason of any other cause which in the absolute discretion of the Engineer-in-charge is (when he is the Accepting Officer of the Contract) beyond the Contractor's reasonable control, then in such case the Accepting Officer on the recommendation of the Engineer-in-charge (or higher authority) may make fair and reasonable extension in the completion dates of the individual items of work or the contract as a whole. Such extension which will be communicated to the Contractor by the Engineer-in-charge in writing shall be final and binding on the Contractor. No other claim in this respect for compensation or otherwise howsoever is admissible. Upon the happening of any such event causing delay, the Contractor shall immediately give notice thereof in writing to the Engineer-in-charge but shall nevertheless use constantly his best endeavor to prevent or make good the delay and shall do all that may reasonably be required to the satisfaction of the Engineer-in-charge to proceed with the work.

10. Patent Rights:

The Contractor shall fully indemnify BHEL or the agent, servant, or employee of BHEL against any action, claim or proceeding relating to infringement or the use of any patent or design or any alleged patent or design rights, and shall pay any royalties which may be payable in respect of any article/ or part thereof included in the contract.

In the event of any claims being made or action brought against BHEL or any agent, or servant or employee of BHEL in respect of matters aforesaid the Contractor shall immediately be notified thereof for taking necessary action provided that payment of indemnity shall not apply when such infringement has taken place in complying with the specific directions issued by the BHEL but the Contractor shall pay any royalties payable in respect of any such use.

11. GST:

GST will be reimbursed to the Contractor on submission of necessary documents of having paid and filed in the GST portal. Any other charges, duties etc. if any shall be borne by the contractor.

12. Royalties

Royalties fixed from time to time as per prevalent local rules will be recovered for material, which the Contractor may be allowed to remove from quarries situated on land which is in charge of the BHEL authorities

13. Plant and Equipment:

The Contractor, shall at his own expense, supply all tools, plant and equipment (here-in-after referred to as T & P) required for the execution of the contract.

14. Assignment or Transfer of Contract:

The Contractor shall not, without the prior written approval of the Accepting Officer, assign or transfer the Contract or any part thereof, or any share, or interest therein to any other person. No sum of money which may become payable under the Contract shall be payable to any person other than the Contractor unless the prior written approval of the Accepting Officer to the assignment or transfer of such money is given.

Sub Contract:

The Contractor shall not sub-let any portion of the Contract without the prior written approval of the Accepting Officer.

15. Compliance to Regulations and Bye Laws:

The Contractor shall conform to the provision of any statute relating to the work and regulations and bye-laws of any local authority and of any water and lighting Companies or Undertakings with whose system the work is proposed to be connected. He shall, before making any variation from the drawings or the specifications that may be necessitated for such connections give the Engineer-in-charge notice, specifying the variation proposed to be made and the reasons there for and shall not carry out any such variation until he has received instructions from the Engineer-in-charge in respect thereof. The contractor shall be bound to give all notice required by Statute Regulations or Bye-laws as aforesaid and to pay all fees, and taxes payable to any authority in respect thereof.

CHAPTER III

PERFORMANCE OF THE CONTRACT

16. Security Deposit:

The details of Security Deposit are provided in detail in the relevant section of this tender.

17. Order under the contract

All orders, notices etc., to be given under the contract shall be in writing typescript, email or printed and if sent by registered post to the address given in the tender of the contractor, shall be deemed to have been served on the date when in the ordinary course they would have been delivered to him.

The contractor shall carry out without delay all orders given to him.

18. Admission to site

The Contractor shall not enter on (other than for inspection purposes) or take possession of the site unless permitted to do so by the Engineer-in-charge. The portions of the Site to be occupied by the Contractor will be clearly defined and marked on the site plan, and the Contractor will on no account be allowed to extend his operations beyond these areas.

The Contractor shall provide, if necessary or required at the Site, temporary access there to and shall alter, modify and maintain the same as required from time to time. He shall take out and clear away the access route when no longer required and restoring the area to its original condition.

The Engineer-in-charge shall have power to execute other works (whether or not connected with the work in the contract agreement) on the site contemporaneously with the execution of the original work and Contractor shall give reasonable facilities for this purpose.

BHEL reserves the right of taking over, at any time, any portion of the site which they may require and the Contractor shall at his own expense clear such portion forthwith. No photographs of the Site or of the work or any part there of shall be taken, published or otherwise circulated without the prior approval of the Engineer-in-charge.

No such approval shall however exempt the contractor from complying with any statutory provisions in regard to the taking and publication of such photographs.

BHEL Officials connected with the Contract shall have the right of entry to the Site at all times.

Engineer - in charge shall have the power to exclude from the site any person whose admission there to may, in his opinion be undesirable for any reason whatsoever.

19. Contractor's Supervision

The Contractor shall either himself supervise the execution of the Contract or shall appoint a competent Agent approved by the Engineer-in-charge to act in his stead. The contractor shall employ an Engineer/Agent having at least a 'Degree of Bachelor of Civil Engineering' from a recognized University.

The Employment of an Engineer/Agent as aforesaid shall not be necessary if the Contractor himself in possession of a recognized technical qualification and is in opinion of the Engineer-in-charge capable of receiving instructions of the Engineer-in-charge and of executing the work to the satisfaction of the Engineer-in-charge. If the Contractor fails to appoint a suitable Engineer/ Agent as aforesaid, the Engineer-in-charge shall have full powers to suspend the execution of work and stop payment of any advances that may have become due until such date as a suitable Engineer/Agent is appointed and the contractor shall be held responsible for the delay caused to the work and no extension of time on this account shall be given to him as stipulated in condition (9) above.

Orders given to the Contractor's Agent/Engineer shall be considered to have the same force as if they had been given to the Contractor himself.

The contractor or his Agent shall be in attendance at the site during all working hours and shall supervise the execution of work with such additional assistance in each trade as the Engineer-in-charge may consider necessary.

The contractor or his accredited agent shall attend when required and without making any claim for doing so, either the Office of the Engineer-in-charge or the work site to receive instructions. The Engineer-in-charge shall have full powers, and without assigning any reason to require the Contractor immediately to cease to employ in connection with the Contract any Agent, servant or employee whose continued employment is, in his opinion undesirable.

The Contractor shall not be allowed any compensation on this account.

20. Labor:

The Contractor shall, during the progress of the work engage sufficient skilled labor to maintain the required rate of progress and of quality to ensure workmanship of the degree specified in the Contract and to the satisfaction of the Engineer-in-charge. The Contractor shall not employ in connection with the works any person who has not completed Eighteen years of age. All the statutory provisions for the safety and welfare of the laborers should be ensured as provided in this tender document.

21. Water:

Water shall be provided by BHEL at free of cost for carrying out the civil works.

22. Temporary Workshops, Stores Etc.

The Contractor shall, during the progress of the work provide, erect and maintain at his own expense all necessary temporary workshops, stores, offices, etc., required for the proper and efficient execution of the work. The planning, siting and erection of these buildings shall have the approval of the Engineer-in-charge and the Contractor shall at all times keep them tidy and in a clean and sanitary condition to the entire satisfaction of the Engineer-in-charge.

On completion of the work all such temporary buildings shall be cleared away and the site restored and left in a clean and tidy condition to the entire satisfaction of the Engineer-in-charge.

23. Stores and Material on Site

All stores and material required for the work are to be deposited by the Contractor only in places to be indicated by the Engineer-in-charge.

Where in accordance with the contract stipulations certain Stores & Material (for incorporation in the work) are to be issued to the Contractor by the BHEL and **such items will be so issued only to the extent required for the actual completion of the work** as stipulated in the contract. The decision of the Engineer-in-charge regarding the quantities to be issued as above shall be final and binding on the contractor. For any excess quantities consumed on the work upto 5% over the theoretical consumption will be charged at issue rates and excess consumption beyond this limit, their cost will be recovered from the Contractor at punitive rates which will be 100% (Hundred Percent) more than the issue rates of the BHEL.

In regard to the material and stores which may be issued to the Contractor by BHEL the Contractor shall give the Engineer-in-charge reasonable notice in writing of his requirements of such stores and material and on the approval of his demand being notified to him, he shall make immediate arrangements for drawing the same. Such stores and material shall be transported by the Contractor at his own expense direct from the place of issue to the site of the work, unless prior written approval is obtained from the Engineer-in-charge to take them to a Store or Workshop elsewhere.

BHEL Officers connected with the Contract shall have the power at any time to inspect and examine any stores or material intended to be used in or on the work, whether on the site or at any factory or workshop or other place where such stores or material are being fabricated or manufactured or at any place where the same are lying and the contractor shall give necessary facilities for such inspection and examination.

The Engineer-in-charge shall be entitled to have tests made of any stores or material supplied by the Contractor who shall provide at his own expense all facilities which the Engineer-in-charge may require for this purpose. If at the discretion of the Engineer-in-charge an independent expert is employed to make any such tests his charges shall be borne by the Contractor only if the test discloses that the said stores or material are not in accordance with the provisions of the Contract.

Should the Engineer-in-charge consider at any time during the construction or re-construction, on prior to the expiry of the "MAINTENANCE PERIOD" that the stores or material provided

by the Contractor are unsound or of a quality inferior to that contracted for or otherwise not in accordance with the contract (in respect whereof the decision of the Engineer-in-charge shall be final and conclusive) the Contractor, shall on demand, in writing from the Engineer-in-charge specifying the Stores or material complained of, notwithstanding that the same may have been inadvertently passed, certified and paid for, forthwith remove the stores or material so specified and provide other proper and suitable stores or material at his own expense; to the entire satisfaction of the Engineer-in-charge. In the event of his failing to do so within a period to be specified by the Engineer-in-charge in his demand aforesaid, the Engineer-in-charge may replace within others the stores or material complained of at the risk and expense in all respects of the Contractor. The liability of the contractor under this condition shall not extend beyond the maintenance period aforesaid except as regards stores or material which the Engineer-in-charge shall have previously given notice to the contractor to replace.

(*MAINTENANCE PERIOD for any work under this Organization will be a minimum of SIX MONTHS or as specified in the tender FROM THE DATE OF ACTUAL COMPLETION of the particular work and handing over to BHEL).

All stores and material brought to the Site shall become and remain the property of BHEL and shall not be removed from the site without prior written approval of the Engineer-in-charge. However, when the work is finally completed, the Contractor shall at his own expense forthwith remove from the site all surplus stores or material originally supplied by him and upon such removal, the same shall revert in and become the property of Contractor. All BHEL Stores and material issued to Contractor for in-corporation or fixing in the work and which, making due allowance for reasonable wear and tear/or waste, have not on completion of the work been so incorporated or fixed, shall be returned by the Contractor at his own expense to the place of issue.

Credit for surplus stores and/ or material returned by the contractor to BHEL will be given to him at a price based on the prevailing market rate but not exceeding that at which the said stores and material were originally issued to him but due consideration shall be given to the allowance claimed by BHEL in respect or any depreciation or damage suffered by the stores and/or material whilst in the custody of the Contractor regarding which the decision of Engineer-in-charge shall be final and conclusive.

If, in the opinion of the Engineer-in-charge (which shall be final and conclusive) any stores, supplied by BHEL have either during currency of the work or after completion of the work whilst under the custody of the Contractor, become damaged to such an extent that they cannot be usefully utilized, either in the same work or in other works, the Engineer-in-charge shall not accept the stores and in the event of his rejection the contractor shall be charged for the said Stores at a rate as fixed by the Accepting Officer. The Contractor shall not be entitled to any claim whatsoever on this account.

24. Tools and Plants on site:

All tools, plants and equipment brought to the site shall become the property of BHEL and shall not be removed from the site without the prior written approval of the Engineer-in-charge when the work is finally completed or the Contract is determined for reasons other than the default of the Contractor he shall forthwith remove from the site all tools, plants, equipment etc., (other

than those as may have been provided by BHEL) and upon such removal, the same shall in, and become the property of the Contractor.

25. Statement of Hire Charges:

A monthly detailed statement of the hire charge incurred in respect of BHEL tools, plants, equipment etc., shall be given to the Contractor by the Engineer-in-charge

26. Precaution Against risks:

The Contractor shall be responsible for providing at his own expense, for all precautions to prevent loss or damage from any and all risks and to minimize the amount of any such loss or damage and for the necessary steps to be taken for the said purpose until the works have been handed over complete in all respect of the Engineer-in-charge.

The Contractor shall be responsible for the protection of the site, the work, the material, tools, plants, equipment and anything else lying on the Site during the progress of the work. He shall be solely responsible for and shall take all reasonable and proper steps for protecting, securing, lighting and watching, all places on or about the work and the Site which may be dangerous to any person whomsoever.

27. Notices and Fees:

The Contractor shall give all notices required by any Statutory provision or by the regulations and/or bylaws of any local Authority and/or of any Public Service, Company or Authority affected by the work or with whose system the same are or will be connected. The Contractor shall pay and indemnify BHEL against any fees and charges payable under such Acts. Regulation and/or bylaws in respect of the work and shall make and supply all drawings and plans required in connection with any such notice.

28. Setting out of the Works and Protective and Maintaining Signals and Works:

The Engineer-in-charge shall supply dimensioned drawings, levels and other information necessary to enable the contractor to set out the work. The Contractor shall at his own expense set accurately according to the drawings and figured dimension thereon, all the work comprised in the contract and any extras or additions there-to and shall be solely responsible for their being so set out and executed. All bench marks, pegs, signals on the surface, alignment stones, milestones and all similar marks whether put in by BHEL Authorities for the purpose of checking the Contractor's work or in the nature of permanent survey marks will during the tenure of the contract, be under the care of the Contractor who shall, at his own expense, take, all proper and reasonable precautions and care to preserve and maintain them in their true position. In the event of these marks being disturbed or obliterated by accident or due to any other cause whatsoever, the same may, if deemed necessary, be replaced by the Engineer-in-charge at the Contractor's expense and the cost thereof deducted from any money then or thereafter becoming due to the Contractor.

Where requested by the Contractor, the level marks, center line and chainage pegs corresponding to those shown on the Drawing will be pointed out to the Contractor on the

ground but all bench marks or chainage pegs additional to those shown on the Drawing will be set out by BHEL authorities.

29. Site Drainage:

All water that may accumulate on the site during the progress of the work or in trenches and excavations shall be removed to the entire satisfaction of the Engineer-in-charge and at Contractor's expense.

30. Excavations, Relics Etc.

Material of any kind obtained from excavation on the site shall remain the property of BHEL and shall be disposed of as Engineer-in-Charge directs.

All gold, silver, oil and other minerals of any description and all precious stones, coins, treasures, relics, antiques and other similar items which may be found in or upon the site shall be the property of Bharat Heavy Electricals Limited and the Contractor shall duly preserve the same to the satisfaction of the BHEL and shall from time to time deliver the same to such person or persons as the BHEL may appoint to receive the same.

31. Foundations

The Contractor shall not lay any foundations until the excavations for the same have been examined and approved in writing by the Engineer-in-charge.

32. Covering-in Work

The Contractor shall give reasonable notice in writing to the Engineer-in-charge whenever any work is to be permanently covered up or concealed, whether by earth or other means so that it can finally be inspected or measured if necessary. In default of so doing, the Contractor shall, if required by the Engineer-in-charge uncover such work at his own expense.

33. Approval of works by Stages:

All work embracing more than one process shall be subject to examination and approval at each stage thereof and the Contractor shall give due notice in writing to the Engineer-in-charge when each stage is ready. In default of such notice being received, the Engineer-in-charge shall be entitled to approve the quality and extent thereof at any time he may choose and in the event of any dispute, the decision of the Engineer-in-charge thereon shall be final and conclusive.

34. Execution of the Work:

The work shall be executed in a workman-like manner and to the satisfaction in all respects of the Engineer-in-charge.

The Engineer-in-charge will communicate or confirm his instructions to the Contractor in respect of the execution of the Work in a "Work Site Order Book" maintained at his office and the Contractor shall visit this office daily and shall confirm receipt of such instructions by

signing the relevant entries in this book. Such entries will rank as order or notices in writing within the intent and meaning of these conditions.

35. Day Work:

No day-work shall be performed without the prior written instructions of the Accepting Officer.

The Contractor shall give to the Engineer-in-charge reasonable notice of the start of any work ordered to be executed by day-work and shall deliver to the Engineer-in-charge within two days of the end of each pay week a return in duplicate giving full detailed accounts of labor and material for that pay-week. One copy of each of these returns, if found correct, will be certified by the Engineer-in-charge and returned to the contractor and must be produced at the time of adjustment of accounts.

An invoice in duplicate signed by the Contractor or his agent shall be sent with each delivery of material for day-work and the Contractor will be furnished with a receipt signed by the Engineer-in-charge specifying the description, quantities weight or measurement (as the case may be) of the articles approved, reference will be made in this receipt in the return aforesaid and the Contractor's Bill.

In the case of Lump Sum Contracts, the rates to be charged and the percentage addition for profit and establishment charges, etc., will be agreed upon between the Accepting Officer and the Contractor prior to the execution of the work.

36. Inspection of the Work:

BHEL Officers concerned with the Contract shall have power at any time to inspect and examine any part of the work and the Contractor shall give such facilities as may be required to be given for such inspection and examination Should Engineer-in-charge consider, at any time during the expiry of the maintenance period, that any work has been executed with unsound, imperfect or unskilled workmanship or of a quality inferior to that contracted for or not otherwise in accordance with the contract (in respect) whereof the decision of the Engineer-in-charge shall be final and conclusive the Contractor shall on demand in writing from the Engineer-in-charge specifying the fault notwithstanding that the same may have been inadvertently passed, certified and paid for, forthwith rectify or remove and reconstruct the work so specified in whole or in part as the case may be required at his own expense to the entire satisfaction of the Engineer-in-charge and in the event of his failing to do so within a period to be specified by the Engineer-in-charge in his demand as aforesaid, the Engineer-in-charge may carry out the work by other means at the risk and expense in all respects of the Contractor. However, the liability of the Contractor under this condition shall not extend beyond the maintenance period except as regards workmanship which the Engineer-in-charge shall have previously given notice to the Contractor to rectify.

37. Responsibility for Building:

In the event of any building or part of any building being handed over to the Contractor for the execution of work thereto under the provisions of the Contract, he shall give a written receipt for all fixtures, glass etc. and he shall be required to make good at his own expense all damages

resulting from any cause whatsoever while in his charge and on completion of the work to deliver the said building or part thereof in a clean state complete in every particular to the entire satisfaction of the Engineer-in-charge.

38. Insurance:

As specified in the tender document.

39. Damage and loss to private property and injury to workmen

The contractor shall at his own expense reinstate and make good to the satisfaction of the Engineer-in-charge and pay compensation for any injury, loss or damage occasioned to any property or rights whatever including property and rights of **BHEL**, (or agents, servants or employees of **BHEL**) the injury loss or damage arising out of or in any way in connection with the execution or purported execution of the contract and further the contractor shall indemnify **BHEL**, against all claims enforceable against **BHEL**, or any agent, servant, or employee of **BHEL** a private person, in respect of any such injury (including injury resulting in death loss or damage to any person) whosoever or property, including all claims which may arise under the workmen's Compensation Act or otherwise, or which would be enforceable against **BHEL**.

40. Completion

The works shall be completed to the entire satisfaction of the Engineer-in-charge and in accordance with the Contractor's forecast of Time and Progress where operative, and all unused stores and material, tools, plants, equipment, temporary buildings and things shall be removed and the site and work cleared of rubbish and all waste material and delivered up clean and tidy to the satisfaction of the Engineer-in-charge at the Contractor's expense and/or before the Scheduled date of completion.

BHEL shall have power to take over from the Contractor from time to time each sections of the work as have been completed to the satisfaction of the Engineer-in-charge.

In case the Contractor fails to remove any of his properties, assets or fails to clear the rubbish and waste material within 30 days of the completion of the contract, it is lawful for the contractee, that is **BHEL** to take such action as it deems fit to clear dispose of such properties, assets or such waste material and charge the contractor any expenses incurred thereon.

The Engineer-in-charge shall certify to the Contractor the date on which the work is completed and the state thereof.

The Engineer-in-charge shall also certify to the Contractor the state of the work at the end of maintenance period, where applicable.

41. Compensation for Delay:

If the contractor fails to maintain the required progress in time as per individual sub work orders or to complete the work and clear the site on or before the contracted or extended period of completion, he shall, without prejudice to any other right or remedy of the **BHEL** on account

of such breach, pay as agreed compensation an amount calculated as stipulated below or such smaller amount as may be fixed by the BHEL on the contract value of the work for every week that the progress remains in time as per the individual sub work orders or that the work remains incomplete.

This will also apply to items or group of items for which separate period of completion has been specified.

For this purpose, the term 'Contract Value' shall be the value at contract rates of the work as ordered.

- a. Completion period (as originally-stipulated) -- at 1 percent per week. not exceeding 6 months.
- b. Completion period (as originally-stipulated) -- at ½ percent per week exceeding 6 months.

Provided always that the total amount of compensation for delay to be paid under this condition shall not exceed the under noted percentage of the contract value or of the contract value of the item or group of items of work for which a separate period of completion is given:

- a. Completion period (as originally-stipulated) -- not 10 percent. exceeding 6 months.
- b. Completion period (as originally-stipulated) -- 7½ percent. exceeding 6 months

The amount of compensation may be adjusted or set-off against any sum payable to the Contractor under this or any other contract with the BHEL.

42. Laws governing the contract:

This contract shall be governed by the Indian Laws for the time being inforce.

43. Cancellation of Contract for Corrupt Acts:

As specified in the tender document.

44. Cancellation of Contract for Insolvency, Assignment or Transfer or Sub-Letting of Contract:

As specified in the tender document.

45. Cancellation of contract in part or in full for contractor's default:

As specified in the tender document.

46. Termination of Contract for Death:

As specified in the tender document.

47. Special Powers of Determination:

If at any time after the acceptance of the tender BHEL shall for any reason whatsoever not require the whole or any part of the work, to be carried out the project Manager/Engineer shall give notice in writing of the fact to the Contractor who shall have no claim to any payment of compensation or otherwise howsoever on account of any profit or advantage which he might have derived from the execution of the work in full but which he did not derive in consequence of the foreclosing of the work.

He shall be paid at Contract rates, for the full amount of the work executed including such additional works, e.g. clearing of site, etc., as may be rendered necessary by the said fore closing. He shall also be allowed a reasonable payment (as decided by the Accepting Officer) for any expenses sustained on account of labor and material collected but which could not be utilized on the work, as verified by the Engineer-in-charge. Neither shall the Contractor have any claim for compensation on account of any alterations having been made in the original specifications, drawings, designs and instructions, involving any curtailment of the work as originally contemplated.

48. Fair Wages:

As specified in the tender document.

CHAPTER IV

VALUATION AND PAYMENT

49. Records and Measurements:

All items having a financial value shall be entered in the BHEL Measurement Book/ eMbook so that a complete record is obtained of all works performed under the Contract.

Work carried out for agreed lump sum will be described and similarly recorded.

Lump sum omissions will be entered for deduction. Measurement shall be restricted to that required to ascertain the financial liability of BHEL under the contract.

Work which fails to be measured in detail shall be measured physically, without reference to any local custom that may obtain excepting where it may otherwise be directed in the tender documents. The measurements shall be taken jointly by any person duly authorized on the part of the BHEL and by the Contractor.

The Engineer-in-charge shall give reasonable notice in writing to the Contractor of appointment for measurement.

The Contractor shall, without extra charge, provide assistance with appliance and other things necessary for measurement.

The Contractor shall bear all the cost of measurement of his work.

Measurement shall be entered in the BHEL Measurement Book and signed and dated by both parties each day at the Site on completion of measurement. If the Contractor objects to any of the measurements recorded on behalf of the BHEL a note to that effect will be made in the BHEL Measurement Book or against the item or items objected to; and such note shall be signed and dated by both the parties engaged in taking the measurement.

If, as a result of such objection, it becomes necessary to re-measure the work wholly or in part, the expense of such re- measurement shall be borne by the party requiring the measurement.

Measurement to be re-taken, provided that a net error is found by this re-measurement to amount to less than 5% (five percent) of the value as recorded by the first measurement. But, where the net errors amount to 5% and over of the said value, then the cost is to be borne by the other party. In any case, if the net value of errors found exceeds Rs. 500/- the expense of re-measurement is to be borne by the other party. If the Contractor's representative fails to attend when required, the Engineer-in-charge shall have power to proceed by himself to take measurement and in that case these measurements shall be accepted by the Contractor as final.

The contractor shall, once every month, submit to the Engineer-in-charge with a copy to the Civil Manager/Senior Engineer details of his claims for the work done by him up to and including the previous month which are not covered by his Contract Agreement in any of the following respects;

- a. Deviation from the items and Specifications provided in the contract documents.
- b. Extra Items/New Items of work
- c. Quantities in excess of those provided in the contract schedule.
- d. Items in respect of which rates have not been settled. He should, in addition furnish a clear certificate to the effect that the claims submitted by him as aforesaid cover all his claim and that no further claims shall be raised by him in respect of the work done up to and including the period under report.

Except where any general or detailed description of the work in quantities expressly shows to the contrary, schedule of quantities shall be deemed to have been prepared and measurements shall be taken in accordance with

the procedure set forth in the schedule of rates specification notwithstanding any provision in the relevant standard method of measurement or any general or local custom. In the case of items which are not covered by the schedule of rates/ specification, measurements shall be taken in accordance with relevant standard method of measurement issued by the Indian Standard Institution or as per standard engineering practice.

50. Valuation of Deviations:

Rates for deviated items of work will be fixed as follows: -

- I. For any item of work required to be carried out after the contract has been awarded and which is not covered by Contractor's Schedule but is covered by BHEL Schedule of rates the rate payable for such a fresh item will be derived from BHEL Schedule by the method of proportion as follows:
 - a. In the same proportion to rate in BHEL Schedule of Rates as the tendered rate for the nearest analogous item of work in Contractor's schedule bears to rate for the particular analogous item of work in BHEL Schedule of rates.
 - b. If a single appropriate analogous item of work is not available in both Schedule (Contractor's and BHEL Schedule) then the method of proportion will be applied to the nearest analogous group of items available in both the Schedules referred to i.e. in the same proportion as the total tendered cost of that particular group of items (the sum of the products of the tendered rates and the quantities for which orders are placed bears to the total cost of the same items and quantities at the BHEL Schedule of Rates.
 - c. If even an appropriate analogous group of items is not available in Contractor's Schedule and BHEL Schedule, then the methods of proportion will be applied to all those items of the whole work, which are available in both the Schedules and for which orders have been placed on the contractor, i.e., in the same proportion as the total cost of all these items of work (the sum of the products of the tendered rates and the quantities for which orders are placed) bears to the total cost of the same items and qualities at the BHEL Schedule of Rates.

II. If any work not covered by any of the foregoing is ordered on the Contractor, the basis of payment shall be decided by the Accepting Officer whose decision shall be final and conclusive and binding on the parties.

The selection of analogous items or analogous group of items referred to above shall be done by the Engineer-in-charge. Where the rates for deviated items or new items of work can be derived by the selection of different analogous items or analogous group of items, the lowest of all such derived rates shall be taken as the correct rate.

In the case of the contracts for which the Engineer-in-charge is the Accepting Officer, all disputes regarding the settlement of rates of deviated or new items or work shall be referred to the Deputy Manager/Manager whose decision shall be final and conclusive as the case may be.

51. Reimbursement / Refund on Variation in Price, Materials:

No Reimbursement/ Refund on Variation in Price, Materials.

52. Advances on Account:

No payment shall be made for work estimated to cost less than Rupees FIVE THOUSAND till the whole of the work shall have been completed and a certificate of completion given by the Competent Authority.

In the case of work estimated to cost more than Rupees FIVE THOUSAND the contractor may at intervals of not less than one month or as otherwise provided for in the Contract Documents, counting from the date on which order to commence work is given by Engineer-in-charge submit claims on BHEL forms for payment of advances on account of work done and of material delivered in connection with the Contract.

The contractor shall be paid in respect of such claims to the extent approved and passed by the Engineer-in-charge subject a maximum of 90% of the value of the work actually executed to the satisfaction of the Engineer-in-charge. The certificate of the Engineer-in-charge regarding such approval and passing of the sums so payable shall be final and conclusive against the Contractor.

“After the full amount of Security Deposit is made up through the 10% deduction from On account” bills, 100% payment of all subsequent bills may be made to the Contractor.

The Contractor may also be paid during the progress of the work 75% of the value of any material which are in the opinion of the Engineer-in-charge in accordance with the Contract, and are actually required for incorporation in the work and which have reasonably been brought to the site in connection therewith and are adequately stored and/ or protected against damage by weather or other causes, but which have not at the time of payment of the advance been incorporated in the work on furnishing a formal hypothecation deed. Payment of such advances, however, shall be purely at the discretion of the Deputy Manager/Senior Engineer provided always that payments shall not be made under these periodical certificates in respect of perishable material like lime, cement, timber, sand, kankar, etc., Any sums/due from the

Contractor on account of Tools and Plant, Stores or any other items provided by BHEL shall be deducted from the respective advances, the Engineer-in-charge shall from time to time certify the sums payable to the contractor after retaining the reserves.

Any certificate relating to work done or material delivered may be modified or corrected by any subsequent interim certificate or by the final certificate and no certificate of the Engineer-in-charge supporting an advance payment shall itself be conclusive evidence that any work or material to which it relates are in accordance with the contract. All such intermediate payments shall be regarded as advances against the final payment only and shall not be considered as an admission of the due performance of the contract or any part thereof in any respect or the accruing of any claim whatsoever.

Such intermediate payment shall not conclude, determine or affect in any way the powers of the Engineer-in-charge as to the final settlement and adjustment of the accounts or otherwise, or in any way vary or affect the contract.

53. Final Bill

As soon as possible after the completion of the work to the satisfaction of the Engineer-in-charge, the contractor shall forward a certified final account on BHEL form, in duplicate. It shall be accompanied by all abstracts, vouchers etc., in support thereof and shall be prepared in the manner prescribed by the Engineer-in-charge. No claims will be entertained after the receipt of the final bill. The Contractor shall be entitled to be paid the final sum less the value of payments already made on account subject to certification of the final bill by the Engineer-in-charge. Any sums due from the contractor on account of Tools & Plant, Stores or any other items provided by BHEL not yet recovered from the contractor shall be deducted from the final sum aforesaid.

No charge shall be allowed to the Contractor on account of the preparation of bills.

54. Payment of Bills:

All payment to be made to the Contractor under this contract shall be only through EFT (Electronic Fund Transfer)

55. Recovery from Contractor:

Whenever under the contract any sum of money shall be recoverable from or payable by the contractor the same may be deducted from any sum then due or which at any time thereafter may become due to the Contractor under the contract or under any other Contract with BHEL or from his Security Deposit or he shall pay the claim on demand.

56. Post Technical Audit of Work and Bills:

BHEL reserves the right to carry out a post-payment audit and technical examination of the work and final bill including all supporting vouchers, abstracts etc., and to enforce recovery of any sums becoming due as a result thereof in the manner provided in the preceding sub-paragraphs provided however that no such recovery shall be enforced after three years of passing the final bill

57. Refund of Security Deposit:

As specified in the tender document.

58. Arbitration:

As specified in the tender document.

GENERAL AND SPECIAL SPECIFICATIONS

1. Site Clearance

All the area upon which the construction is to be carried out and areas which are required by the Contractor for his construction facilities are to be cleared off all rubbish and objectionable matter at Contractor's own cost. Trees, if any, shall not be uprooted or cut without the prior approval of the Engineer-in-charge. All spoils, unserviceable material and rubbish shall be burnt or removed from site. Usable material, saleable timber, fire-wood etc., shall be stocked properly at work site in the manner as directed by the Engineer-in-charge. The cost of clearing the areas shall be deemed to have been included by the tenderer in his general rate.

2. Earthwork for Foundations

Earthwork excavation for foundations and filling in foundations shall conform to TNBP 23 and 24. The area to be excavated or filled in with excavated material shall be clearly demarcated in the field by the Contractor. Excavation shall be done to lines and levels defined. Excavation shall be carried out to such widths, lengths, depths, profiles and grades as shown in the drawing or as may be specified by the Engineer – in – charge. Rough Excavation may be carried out up to a depth 15 cm less than the final level but the balance shall be excavated to precise level with special care. All soft pockets of soil met with even below the final level shall be removed and the excavation filled up as directed by Engineer-in-charge. The methods of excavation shall in every case be subject to the approval of the Engineer-in-charge and the contractor shall ensure the safety and stability of the excavations, being executed by him as well adjacent buildings, structures, services and other works in the vicinity of the site of work. Wherever necessary Engineer-in-charge may direct that the sides of the excavation should be timbered and shored at the contractor's own cost, adopting a proper method approved by the Engineer-in-charge.

Notwithstanding the above, should any slip occur, the contractor shall remove all the slipped material from the excavated pit, at his own cost. He shall also make good at his own all damages caused to the work as well as adjacent buildings, structures etc., as a result of the slip, referred to.

All excavation work shall be subject to inspection and approved by the Engineer-in-charge before any further works in the excavated areas allowed to commence. Should any excavation be carried out beyond the specified depth, the contractor should fill it up at his own cost with the same type and class of material as it is proposed to be laid over the excavated portion. No payment will however be made to the contractor on his account.

The contractor shall ensure that the excavations and the structures under construction are kept free from water logging at all stages of construction. He shall take all necessary precautions and

streams, aquifers, springs, surface flows etc., are excluded effectively so as to ensure that the works are carried out in a reasonable dry conditions in accordance with the construction schedule.

Back filling around the foundations, trenches, plinth and under the floor shall be done in accordance with TNBP 24 and 25. The finished level of the plinth filling shall be trimmed to the slope required to be given to the finished floor. Back filling, watering and consolidation of excavated earth in layers etc., complete as per specifications shall be done unless otherwise stipulated in the tender schedule.

Removal of Hard rock by Blasting:

This shall include all rock occurring in large masses which cannot be removed except by blasting. Blasting shall be done in conformity with TNBP 19 & 23 and as instructed by the Engineer-in-charge. When rock blasting has to be done adjacent to structures, the following precautions shall be observed.

- a. All blasting should be completely muffled to prevent damage by flying pieces.
- b. Blasting within 3 meters of the structures shall be avoided
- c. No blasting should be done within 1.5 meters of concrete/ masonry structures.
- d. An isolated boulder extending under the existing structure but projecting within the area of blasting should be blasted.
- e. The contractor shall be responsible for all damages caused by blasting and shall replace or repair the damaged structures at his own cost.

3. Plain and Reinforced Cement Concrete Works:

All design and construction shall be performed in accordance with the Indian standard code of Practice for plain and reinforced concrete – IS 456 and TNBP 30. Any Special requirements noted on the drawings or bill of quantities shall govern over the provisions of this specifications. Controlled concrete shall be used wherever specified in the schedule of items complying with all requirements of IS: 456 and as per special specifications appended herewith.

The coarse aggregate to be used shall be of hard broken granite stone jelly of various sizes as specified under respective items in the Bill of Quantities, conforming to IS 383 latest edition. The Engineer-in-charge may require the contractor to carryout moisture content tests in both fine and coarse aggregates. For determination of moisture content IS – 2386 shall be referred to. The amount of water to be added shall be then adjusted to compensate for any observed variation in the moisture contents. Proper control of mixing water is deemed of paramount importance. Mixtures with automatic water measuring drums shall be used or else. Water should be measured by volume in calibrated buckets. All measuring equipment shall be maintained in a clean serviceable condition and the accuracy periodically checked and got certified by the Engineer-in-charge. The contractor shall carryout slump tests apart from taking test cubes at regular intervals. All such methods of sampling and analysis of concrete shall be in accordance with IS – 1199.

Mixing of concrete shall be strictly carried out in an approved type mechanical mixer. The mixing equipment shall be capable of combining the aggregates, cement and water within the specified time (not less than 2 Minutes) into a thoroughly mixed and uniform mass and of discharging the mixture without segregation. Mixing shall be continued until there is a uniform color and

consistency, Concrete shall be handled from the place of mixing to the place of final deposit as rapidly as practicable by methods which will prevent segregation or loss of any of the ingredients. Before depositing the concrete, all debris and dirt shall be removed from the space to be occupied by concrete. Concreting shall not be done unless the formwork conform to the shapes, lines and dimension as shown in the drawings.

Unless otherwise approved, concrete shall be placed on single operation to the full thickness of slabs and beams and similar members and not exceeding 1-meter-deep in walls, columns and similar members. Concrete shall be placed continuously until completion of the part of the work between construction joints or as directed by the Engineer-in-charge. The concrete after being laid shall be compacted by means of vibrators of approved type under proper supervision as directed by the Engineer-in-charge. Care should be taken to avoid segregation and formation of air bubbles. The whole process starting from the mixing of concrete to the placing and compaction shall not take more than 20 minute and the process shall be completed before the initial setting takes place. Curing shall be accomplished in accordance with IS-456 by keeping the concrete covered with a layer of sacking, canvas or similar absorbent material and kept constantly wet for the period as directed by the Engineer-in-charge.

Reinforcement:

All reinforcement shall be clean and free from pitting, loose mill-scales, dust, loose rust and coats of paint, oil or other coatings which may destroy or reduce bond. General construction details and workmanship relative to reinforcement including bar bends, lap splices and installation shall be in accordance with the IS-2502 as well as IS-456. All bars be bent as per the bar bending schedules indicated in the drawings or supplied separately relevant to particular drawing. The contractor shall in all cases verify himself the correctness of schedules, giving the number, length and the bending details of the bars. The numbers, sizes, shape and position of all the reinforcement shall, unless otherwise, directed or authorized by the Engineer-in-charge be strictly in accordance with the drawing. The reinforcement shall be adequately held in position by 18/ 20 SWG soft black annealed binding wire. The contractor must obtain the approval of Engineer-in-charge for the reinforcement placed, before any concrete is placed in the form. All reinforcing bars shall be so tied as to form a rigid cage to prevent displacement before or during concreting. Rate quoted for reinforcement should include cost of transporting M.S. Rods/ CTD bars from BHEL Store to site of work, cleaning, cutting, bending, placing, binding with contractor's own binding wire and providing necessary cover blocks of concrete but excluding cost of steel which shall be supplied free of cost at BHEL Stores.

Form Work:

Formwork shall conform to the shape, lines and dimensions of concrete and RCC structures as shown in the drawings and shall be well within the permissible tolerance. Formwork for concrete shall be of plywood, steel, good seasoned timber or other approved material, properly designed easy for removal and cleaning. They shall be of sufficient strength and rigidity to maintain their position and shape under loads incidental to placing concrete. The number of props, their sizes and dispositions shall be such as to be able to safely carry the full dead load area constructional loads. The arrangement and alignment of formwork shall be got approved by the Engineer-in-charge prior to concreting. However, this shall not relieve the contractor from his responsibility for proper work and safety. Formwork shall be sufficiently tight to prevent loss of cement slurry from the concrete. All joints and holes in the formwork shall be caulked with putty jute cloth or

other approved material to the satisfaction of the Engineer-in-charge. The stripping time for the shuttering and the formwork shall in general conform to the provisions in the relevant clauses of IS 456. Unless otherwise specified rates for reinforced cement concrete shall include cost of centering, shuttering charges also.

Expansion and Other Joints:

Expansion Joints in concrete structures shall be provided at specified places as indicated in the drawings. The material shall be as specified by the Engineer-in-charge, expansion joints, with or without metal strip shall be as shown on drawings the filler shall be “EXPANSION JOINT FILLER” pre-molded non – extruding type fibrous joint filler impregnated with bitumen conforming to IS: 1838. The filler shall be durable, waterproof, compressible and shall have a high degree recovery after compression is released, ensuring thereby that no free space develops in the expansion joints. The top 25 mm, or as specified in the drawings, shall be sealed with “SHALITEX SEALING COMPOUND” or equivalent after application of approved primer.

4. Stone Masonry:

General:

Stone masonry shall conform to TNBP 35. Stone shall be obtained from the approved quarry and shall be free from decay and weathering.

All stones shall be thoroughly wetted before use. The mortar used for jointing shall be as specified under the respective items of the ‘Bill of Quantities’.

The walls shall be carried up truly plumb. Every stone shall be carefully fitted to the adjacent stones so as to form neat and closed joints.

To give sufficient lateral bond, vertical joints shall be avoided. Prescribed number of headers as required shall be provided to give sufficient transverse bond. At junctions of wall the stones each alternate course shall be so carried into each of the respective walls as to unite the work thoroughly. Where breaks are unavoidable in carrying up the work continuously in horizontal course sufficiently long steps shall be left to join the old and new work building of two thin faces and filling up the middle with small stuff or dry packing shall be strictly avoided. When plastering or raised pointing is not required to be done joints shall be struck flush and finished simultaneously.

Coursed Rubble Masonry:

Coursed rubble masonry shall conform to TNBP 35-H, I and J. Faces shall be accurately squared and all face joints shall be dressed at right angles. This bushing on the facing stones shall not project more than 38mm.

Face stones shall be laid alternate headers and stretchers. Depth of each course shall not be less than 150 mm. No course shall be greater than any course below. The height shall not exceed the breadth of stones of face. No stone shall tail into the wall less than its height. No pinning shall be allowed on the face. The stones shall be solidly bedded set full in mortar with joints not exceeding 12 mm in thickness.

Random rubble masonry:

Random rubble masonry work shall conform to TNBP 35-L and J. Stones shall be hammer dressed at faces and joints to enable them to come into close proximity with each other. The face stone shall be laid headers and stretchers alternately, so as to break joint by at least 75mm. Thickness of joint shall not exceed 12mm. No pinning shall be used on the face and face stone shall extend well back into the headers. Stones less than 130 mm. in height shall not be used on the face.

Bond stones running through the wall shall be provided at 1.8M intervals in walls up to 0.60 M. thickness and if the wall is more than 0.60 M. thick a line of headers shall be laid from face to back each header overlapping the other by at least 150 mm.

5. Brick Masonry:

Brick works shall be classified as first or second class according to the classification of bricks used and the method of laying. The thickness of joints shall not exceed 6 mm. In first class brickwork and 10 mm in second class brick work.

First class Bricks: Brick shall be sound, hard, tough, rectangular in shape and size, well burnt of uniform deep red or copper color and conform to IS – 1077.

Brick shall be free from cracks, chips, flaws, stone or humps of any kind. Bricks shall be homogeneous in texture and emit a clear ringing sound on being struck and shall have a minimum compressive strength of 50KG/ sq.cm. and shall not absorb water more than 20% of its weight, when soaked in cold water for 24 Hrs. All bricks shall be table molded.

Second Class Bricks: These shall be ground molded but should otherwise conform to the specifications of first class bricks except for some surface cracks are allowable. These shall have minimum compressive strength of 50 Kg. /sq.cm.

Samples of each type of brick, shall be got approved by the Engineer-in-charge before being used. All subsequent deliveries shall be up to the standards of the approved samples.

Brickwork shall conform to TNBP31 and IS –2212.

Bricks shall be well soaked before use on works for at least 6 hrs. The soaked bricks shall be kept on wooden planks or platform. Brick required for masonry with clay or lime mortars shall not be soaked.

Brickwork shall be laid with specified mortar to be prepared in accordance with IS –2250. Brick works shall be laid in English Bond unless otherwise specified. Half or cut bricks shall not be used except when needed to complete the bond. Each course shall be taken up truly plumb, if battered, the batter is to be truly maintained. The level of brickwork shall be checked up at every one-meter interval. Bricks shall be laid with frogs upward. While laying, bricks shall be thoroughly bedded and flushed in mortar and tapped into position with a wooden mallet and the superfluous mortar removed. Walls of all structures shall be carried up regularly in all cases, leaving no part, one meter lower than the other. Where the masonry of one part has to be delayed, the work shall be racked back according to bond (and not toothed) an angle not exceeding 45 Deg. But the racking back should not start within 60cm. of a corner vertical joint. Joints in

alternate courses shall come directly over one another. The brickwork shall not be raised more than 14 courses per day. All iron fixtures, pipes, conduits, drains, sleeves, bolts, holdfasts of doors and windows etc. which are required to be built in walls shall be embedded in cement mortar or cement concrete as specified, in their correct position as the work proceeds.

Joints:

Joints shall be restricted to 6 mm in first class brickwork and 10mm in second class brick work. All bed joints shall be normal to the pressure upon them, radial in arches and at right angles to the face in battered retaining walls. Care shall be taken that all joints are fully mortared (proportion as specified in the schedule items) well flushed up and in case where no pointing to be done, neatly struck as the work proceeds. The joints in faces which are to be plastered or pointed shall be squarely raked out to a depth of 12 mm while the mortar is still green. The raked joints shall be well brushed to remove loose particles. After the work the faces of work shall be cleared well by brush so as to remove any splashed mortar during the course of raising the brickwork.

Curing:

Green work shall be protected from rain by suitable covering. Masonry work shall be kept thoroughly well-watered on all faces for at least 10 days after completion. In case of fat lime mortar curing shall commence two days after laying of masonry and shall continue for seven days.

6. Scaffolding

Scaffolding will generally be single but may be double if warranted for the particular work as approved by the Engineer-in-charge. The contractor shall take all measure to ensure safety of work and the working people.

Payment for brickwork shall be made on cubic meter basis on the volume of actual work done. Half brick wall and brick on edge wall shall be paid on square meter basis. The rate of brick work shall include scaffolding and all items mentioned above and no extra payment will be made for cutting bricks if required either for openings or for rounding or insertions or for recesses at the time of brick wall construction.

7. Damp Proof Course

Damp proof course shall either be with cement concrete or with cement mortar of specified thickness as mentioned in the relevant item of schedule. Damp proof course shall not be carried across doorways. It shall be laid for all walls except verandah retaining wall or for particular wall only as directed by the Engineer-in-charge. It shall be laid flush with floor level or as instructed by the Engineer-in-charge.

Damp proof course with cement concrete shall be of 25 or 38 mm thick in cement concrete M15/M20 as specified using 12mm. and down size aggregate, well rammed and smoothed with trowel. It will be kept wet for 40 hours and after it has dried, two coats of hot bitumen shall be applied over it and allowed to dry after which sand shall be sprinkled over it.

Damp proof course with cement mortar shall be 12 or 20 mm thick in cement mortar 1:3 well mixed with crude oil at 5% by weight of cement used.

8. Cement Plastering:

Cement plastering shall be in accordance with IS – 1661 and TNBP –56 & 57, Cement mortar shall conform to IS – 269. The mortar of specified mix and thickness shall be used.

The surface to be plastered shall be thoroughly cleaned so that it is free from dust, oil, salts etc., The joints of masonry shall be raked out to a depth of at least 12 mm. On cement concrete surfaces the surface shall be cleaned with wire brush and scarified by lines with trowel or hacking done. The surfaces in both cases shall be washed properly and kept wet for 4 hours before plastering is commenced.

Plastering shall be started from top and gradually worked down towards the floor. It shall not at any place be thinner than specified. To ensure even thickness plaster of about 15 cm X 15 cm shall be first applied horizontally and vertically at not more than 2 meters' intervals over the entire surface to serve as gauges. The surface of these gauges shall be truly in the plane of finished surface. The mortar shall then be laid in the wall or other surfaces between the gauges and finished even. All corners shall be rounded to a radius of 24 mm unless otherwise directed. The contractor shall not be paid for any extra thickness of plaster done than as specified.

Plaster, when more than 15 mm thick shall be applied in two coats, a base coat followed by the finishing coat. Thickness of the base coat shall be just sufficient to fill up unevenness in the surface, no single coat, however, shall exceed 12mm in thickness. The under coat shall be roughened or scratched before it is fully hardened.

Curing shall start 24 hours after the plaster is laid. It shall be kept wet for 14 days. During this period, it shall be suitably protected from all damages at the contractor's cost by such means as approved by the Engineer-in-charge.

Any cracks which appear in the surface shall be cut out in rectangular shape and redone as directed by the Engineer-in-charge. Wherever specified standard waterproofing compound as approved by the Engineer-in-charge shall be added to the mortar at the rate of 2% or as specified by the manufacturer by the weight of cement for which the rate shall be paid separately. The rate for plastering shall include cost of scaffolding, swing etc., needed for the work with labor and material all complete.

9. Steel Door, Windows and Ventilators:

All steel doors, windows and ventilators shall conform to IS – 1038, IS – 1361 and IS 1081 or equivalent as mentioned in the bill of quantities and as approved by the Engineer-in-charge.

Rolled steel sections shall conform to Is – 226. The sections shall be cold straightened and finished goods shall be free from bends and other defects. Material used in the fabrication shall be the best procurable and conforming to relevant IS specification. Thickness and specification of the glass to be provided shall be as indicated in the relevant item of the bill of quantities. Glass shall be free from flaws, specks, bubbles, etc., Bolts, nuts, screws, peg stays and other mild steel fittings shall be treated for corrosion as per relevant Indian Standards. Putty for glazing shall conform to IS – 420.

Doors, windows and ventilators, etc., shall be truly square and free from twist and warp. They shall be constructed of sections which have been cut to the required lengths and welded or riveted at the corners as per standard specifications.

All steel surfaces shall first be thoroughly cleaned free of rust scale or dirt and mill scale by approved means and shall be painted with one coat of approved primer conforming IS – 102 before dispatch. Alternatively, if specified they may be galvanized by the “Hot dip” zinc spray or electro galvanizing process described IS – 1361. Doors, windows and ventilators shall be fixed in positions, as specified under IS 1081.

Whenever contractor is required to supply the doors, windows and ventilators etc., he shall first submit to the Engineer-in-charge, the details about source of supply, detailed drawing and specifications etc., for prior approval.

10. M.S Rolling Shutters:

It shall be of approved quality, made out of 18 gauge 75 mm black laths mechanically operated by reduction gear type mechanism. It shall be fitted with two self-aligning ball bearing with locking arrangements (both inside and outside) including MS pressed side guides bottom rails brackets and top rolling spring pressed etc., complete provided with locking arrangements for padlocks, pulling hooks, handles, top cover etc., It shall be painted with one coat of approved primer conforming to Is – 102 before dispatch.

11. Wooden Doors, Windows and Ventilators:

All wood work for doors, windows, ventilators cup board, shelves, etc., conform to relevant IS specification and TNBP 82 and shall be well seasoned teak wood or well-seasoned country wood (pillamarudu or karumarudu) as the case may be. Timber shall be best quality and shall be free from knots, injurious open shales, bore holes, decay, soft or spongy spots, hollow pockets and all other defects and blemishes. Timber shall conform to IS 1003 (Part 1). Size of doors, windows and ventilators shall be as specified in the relevant item of schedule and detailed drawings and generally in conformity with IS – 1003, part I and part II. The rates for doors, windows and ventilators etc., shall be for the finished work inclusive of fixing them in position with necessary iron hold fasts and furniture fitting of oxidized iron or aluminium or oxidized brass as stated in the description of the relevant items of the bill of quantities and as directed by the Engineer-in-charge. Fittings and furniture shall be of best quality and machine made and robust type. Wherever glazed shutters are to be provided, the cost of glass panes of specified thickness and fixing them in position should be included in the quoted rate. All glass shall be of superior quality from approved manufacturer. In case of solid core flush doors, they should conform to IS:2202 Part I and Part II. The flush door shutters should have a finished thickness as specified in the scheduled item. Flush door shutters shall be obtained from firms of repute as approved by the Engineer-in-charge.

12. ROOFING:

(A) R.C.C Slabs:

Roof slab shall be of RCC of specified mix conforming to IS: 456, with adequate main tensile, transverse and adhesive reinforcement of ribbed steel bars of mild steel rounds. Unless otherwise mentioned the rates for RCC slab shall include cost of concrete, centering and shuttering charges,

vibration charges, rounding of corners, curing and finishing etc., complete. Expansion joints in reinforced cement slabs shall be as per TNBP 30.

The ceiling should be finished as per Clause 30 of TNBP. No extra payment shall be made towards cost of ceiling plaster necessitated on account of defective centering material used or poor workmanship.

The top of roof slab shall be finished with weathering course treatment if so specified. The weathering course work shall conform to TNBP 44-HJ and consist of concrete with broken brick in neat slacked lime of specified thickness finished with one course of pressed split tiles/ pressed tiles of specified thickness and size as described in the bill of quantities.

(B) Roofing and Side Cladding with A.C. sheets:

The A.C. sheets shall be of specified and approved quality and shall conform to IS 459- 1962 in all respects. The sheet shall be laid with the smooth side upwards and with a minimum end lap of 15cm. and for every flatter slopes this should be 20cm. The laying operation shall include scaffolding works involved. Sheets shall be secured to the purlins by means of 8mm galvanized iron J or L hook bolts and nuts. The grip of the hook bolt on the side of the purlin shall be not less than 25mm. Each bolt shall have a bitumen washer and galvanized iron washer placed over the sheet before the nuts are screwed down from above. Hole for hook bolts etc., shall be drilled and not punched in the ridges of the corrugations in the exact positions. The diameter of these holes shall be 1.5 mm more than the diameter of the fixing bolts. The payment will be on square meter basis of the laid area.

13. A.C. Rain Water Pipes

The pipes shall be of standard quality conforming to IS 1628. These shall be straight, true smooth and regular in thickness. They shall be free from cracks and other flaws. The supply shall include all necessary pipe fittings and accessories.

All pipes shall be fixed to wall or columns by standard M.S butt holder clamps of approved make. The spigot of the upper pipe shall be properly fitted into the socket of the lower pipe, such that there is uniform annular space for filling with the jointing material. One third depth of this annular space is to be filled with spun yarn soaked in bitumen of approved quality and properly pressed with caulking tool. The remaining two, third depth of the joint is to be filled with Cement Mortar 1:2 (1 Cement: 2 coarse sand) and shall be pressed with caulking tool and finished smooth at the top at an angle of 45 Deg. sloping up.

The rate shall include supplying and fixing of pipes with specials and accessories, including sizing as required, jointing, testing, cutting of walls and making good necessary scaffolding etc., complete.

14. Flooring:

Flooring shall consist of a base course of cement concrete of specified thickness and proportion laid over the compacted earth or sand filling as specified and a finishing layer of concrete, mosaic, glazed tiles or any other material as specified to be laid. Flooring work for Factory shop floors as well as mosaic flooring shall be done as per the special specifications.

The bed flooring shall be prepared either level or sloped as per relevant drawing or as instructed by the Engineer-in-charge. Filling in basement with earth or sand shall be in accordance with TNBP 25. On the prepared bed, cement concrete of specified mix and thickness shall be laid and well consolidated.

A. Ellis pattern, 1st Sort Flooring

On the clean wet surface of the concrete base before it has set, will be laid a layer of cement concrete to give a finished depth of 20/25 mm over the base concrete. The cement concrete will be of 1:3 proportion (one cement and 3 hard broken stone chippings 3 to 10 mm Size). To make a colored floor red oxide iron powder or other approved material should be mixed with cement at the rate 10% of the weight of cement or as directed by the Engineer-in-charge. Ellis pattern flooring shall be done as described under clause 41-G of TNBP.

B. Glazed Tile Flooring

The tiles shall be of ceramic white or colored and of specified dimensions as described in the schedule item. The top surface of tiles shall be glazed with a neat finish of uniform color and texture and free from flaws, cracks, craze, specks or other imperfections. Tiles shall be true to shape with straight edges, non-absorbing and non – fading. Samples of tiles together with manufacturer's literature shall be submitted to the Engineer-in-charge for approval. Tiles shall conform to IS 177 latest.

Over the prepared surface of the floor a bedding layer of Cement Mortar (1:3) of specified thickness shall be laid-in-proper level and slope using screed patterns. The bedding layer shall be deeply scratched while it is set. A mortar set bed of 6mm thickness in cement lime mortar 1:1:3 (one cement one lime putty and three sand), shall be laid over the bedding layer. After mortar setting, bed has been leveled, a skin of neat cement shall be troweled to the mortar setting bed immediately before the tiles are set. As soon as the mortar setting bed has sufficiently hardened, all tiles shall be finally secured in place and gently beaten in and finished surface brought to desired level. When grouting the glazed tiles, special care shall be taken to prevent scratching of the glazed surface. Joints shall be pointed with white or colored cement to match the tile surface and cured. No joint shall be more than 1.5 mm thick.

15. White Washing and Color Washing

White washing and color washing shall be done as per clauses 63 and 64 of TNBP. The surface shall be thoroughly cleaned off mortar drops and foreign matter. All patching must be scraped properly. The white washing shall be done from pure shell lime/ Janathacem. Samples of lime shall be got approved by the Engineer-in-charge. The wash shall be applied with a brush, the coats being laid on vertically and horizontally alternatively, each coat being allowed to dry before next coat is applied. For color washing the desired shade shall be obtained by mixing approved quantity of coloring matter or distemper with shell lime solution and applied as per white. The contractor shall take every precaution to prevent white wash being splashed on wall, floor and other places and articles not to be white washed. No color wash shall be done unless a sample pattern of the mixed color has been approved by the Engineer-in-charge. The rates shall be inclusive of scaffolding charges, cost of ladder etc.,

16. Painting

All painting work shall be done in accordance with TNBP-66 and the relevant Indian Standard Specifications. Paints, varnishes, cement paints etc., shall be of the highest grade and product of well-known approved manufacturer and shall be delivered to site in original sealed containers. It is desired that material of one manufacturer only shall be used as far as possible. Colors shall be uniform and nonfading. Samples of all colors selected shall be submitted to the Engineer in charge for approval before bulk purchase is made. All finished work shall match corresponding samples kept with the Engineer.

Preparation of Surface:

Before painting wooden surfaces, protruding timber fibers shall be removed and nail marks shall be covered with putty. The surface shall be thoroughly cleaned and sand prepared. In case of steel work, it shall be scraped, well brushed and cleaned free of rust, scale dirt. Base preparation for painting concrete, masonry and plastered surfaces shall be carried out as per IS 2395 – Part I. Before actually proceeding with the work of painting the concrete, masonry and plastered surfaces, it shall be verified that the surfaces are completely dry, free from efflorescence and alkaline effect.

Application:

The primer shall be applied with brushes and spread as evenly and as smooth as possible. For steel work a priming coat of Red Oxide/ Zinc Chromate paint shall be applied. Painting shall be done by skilled laborers in a work-man like manner. All coats shall be of proper consistency and shall be well brushed out, so that no brush marks are visible. The under coating should be nearest to the specified color of the finishing coat. Unless otherwise specified ready mixed synthetic enamel paints shall be used for painting, wood and steel work. Under coats should be completely dry before finishing coat is taken up. Priming coat and under coat shall be rubbed with sand paper and dusted clean. The finished coat of approved paint shall then be applied.

17. Cement Painting

Cement Paint solution shall be applied to the surface with hair brushes in a number of coats to get uniform finish. After the first coat of paints has hardened, it shall be cured with water at least for 24 hours. The surface shall be wetted again before the application of the second coat. At least 24 hours should lapse between the two coats, number of coats shall be as specified in the schedule of quantities. It shall be kept damp at least for seven days.

18. French Polish

French polish to be used shall comply with IS 348. Polishing shall be obtained by dissolving 1 lbs., of shellac in one gallon of methylated spirit without applying any source of heat. After the shellac has dissolved $\frac{1}{4}$ lbs. of cobalt, $\frac{1}{4}$ lbs. of lobano and 0.4 oz. of crystals of desired pigment shall be added. The solution shall be applied with a pad of fine muslin cloth tied as per general practice. The pad shall be dipped into the solution and wrung with fingers and be rubbed hard on the surface in this way, the first coat is to be given after this gets dried up, the successive coats shall be given in the same fashion till the mirror like surface is obtained. The wood to be polished shall be first applied with a filler composed of 1.25 Kg. of whiting mixed with one liter of methylated spirit and then sand papered when dry. The finished surface shall have uniform texture and gloss. Approved transparent sealer shall only be used in base preparation.

SPECIAL SPECIFICATION FOR CONTROLLED CONCRETE

A. PROPORTIONING MIX:

The proportion of aggregate, Cement and water to be used for controlled concrete shall be designed by preliminary tests of the material to be actually used to obtain the densest workable concrete requiring the minimum quantity of cement paste for binding the material to give the required strength. However, the maximum total quantity of aggregate by weight per 50 kg. of cement shall not normally exceed 450kg All proportions shall be by weight. However, water may be added by weight or volume.

B. MIX DESIGN:

Immediately upon the receipt of the award of the contract, the Contractor shall inform the Engineer-in-charge the exact location of the sources of material which he proposes to use and get the material approved. The mix with the actual approved material to be used shall be got designed by the Contractor in an approved laboratory chosen by BHEL and got approved by the Engineer-in-charge. These proportions shall be used so long as the material continue to be of the same quality and from the same sources. If during the progress of work, the Contractor wishes to change the material, the proportions shall be fixed on the basis of fresh preliminary tests to give the required strength. No change of material shall be allowed unless fresh tests with new material show satisfactory results.

C. STRENGTH REQUIREMENTS OF CONCRETE:

Controlled concrete shall be in the following grades, M 15, M 20, M 25, M 30, M 35 & M 40. The concrete mix shall be designed to produce the grade of concrete having the required workability and characteristic strength not less than the appropriate values (as per I.S. 456) as given in table below:

Sl. No	Grade of. Concrete	Specified Characteristic Cube Strength	
		Preliminary test N/mm ²	Works test N/mm ²
1.	M 15	20	15
2.	M 20	26	20
3.	M 25	32	25
4.	M 30	38	30
5.	M 35	44	35
6.	M 40	50	40

D. WORKABILITY OF CONCRETE:

The proportions chosen shall be such that the concrete is of adequate workability for the conditions prevailing on the work in question, and shall be properly compacted. Water shall be added to the mixer to give the required workability. The water content of each batch shall be adjusted as necessary to maintain the required workability with simultaneous adjustment of cement concrete such that the water cement ratio is not changed. The workability tests shall be carried out in accordance with IS: 1199 - Latest, "Methods of sampling and analysis".

Workability of concrete shall be controlled by direct measurement of water content, making allowance for any surface water in the fine and coarse aggregates. Allowance shall be made for surface water present in the aggregate when computing the water content. Surface water shall be determined by one of the field methods described in IS: 2386, Part III.

E. CONSISTENCY AND SLUMP:

The concrete shall have a consistency such that it will be workable in the required position. It shall be of such consistency that when properly vibrated it will flow around reinforcing steel and all embedded parts. The slump for concrete as determined by slump tests as per Indian Standard 456 (latest edition) shall not exceed the maximum slumps indicated below for each type of construction as approved by the Engineer-in-charge.

Workability	Slump in mm		Type of Construction
	Min	Max	
Medium	40	80	All RCC works

The contractor shall not place concrete having a slump outside the limits specified without the approval of the Engineer-in-charge.

At least one slump test shall be made for every compressive strength test carried out. More frequent tests shall be made if there is a distinct change in job conditions or if required by the Engineer-in-charge.

F. TESTS:

Test shall conform to the specifications laid down in IS: 456. These tests shall be got done in an approved laboratory and in accordance with IS: 516 - Latest at the cost of the Contractor (for making necessary cube moulds, transporting the cubes to the Laboratory and all other incidental etc.). The test fees for the cubes shall be borne by the contractor. In order to ensure proper quality control sampling of the concrete of each specification placed on any day in work shall be done in accordance with the following table.

Quantity of Concrete in work	Total Number of samples (each sample to consist of 6 test cubes)
Upto 5.00 Cu.m.	1
Greater than 5.00 Cu.m. and less than 15.00 Cu.m	2
Greater than 15.00 Cu.m. and less than 30.00 Cu.m	3
Greater than 30.00 Cu.m. and less than 50.00 Cu.m.	4
Greater than 50.00 Cu.m	4+one additional sample for each additional 50 Cu.m. or part thereof.

The sampling shall be spread as evenly as possible throughout the day. When wide changes in weather conditions occur during concreting, additional samples may be taken as desired by Engineer-in-charge. Each sample shall consist of 6 cubes of 15 x 15 x 15 cm concrete. Test cubes shall be kept immersed in water until required for test which will be usually at 7 days and minimum crushing strength of not less than the following:

Grade of Concrete	M15	M20	M25	M30	M35	M40
Crushing strength in N/mm ² at the end of 7 days	10	13.5	17	20	23.5	27
Crushing strength in N/mm ² at the end of 28 days	15	20	25	30	35	40

All costs connected with the preliminary tests for proportioning the mix, sampling, curing, handling, other incidental charges, labor charges and cost of material shall be borne entirely by the Contractor. Testing charges for cubes (work tests) shall be borne by contractor. Such testing shall normally be conducted at the BHEL Central Laboratory or any other approved laboratory as directed by the Engineer-in-charge.

All samples for tests shall be taken in the presence of Engineer-in-charge and the Contractor or his authorized agents.

A set of six specimens from random mixer batches, shall constitute a test, three being tested for 7 days and three being tested for 28 days' strength.

The strength test result shall be the average strength of the three companion test specimens, tested at 28 days, except that, if one specimen in a test shows manifest evidence of improper sampling, moulding or testing, the result shall be discarded and the remaining two strengths averaged.

Normally, 7 days and 28 days' tests shall be made on specimens. For any mix, a correlation between 7 days and 28 days' strengths may be made in the laboratory. Soon after a job starts, a similar correlation will be evolved for samples of a concrete taken from the mixer. After that correlation has been established, the results of the 7 days' test may be used as an indicator of the compressive strength which should be expected at 28 days, provided such results are consistent, if 7 days' tests shown compressive strength that are too low, corrective measures shall be taken at once, at the Engineer's direction, without waiting for the results of the 28 days' tests.

Each class of concrete shall meet the following strength requirements:

The average of any three consecutive strength tests shall have a value equal to or greater than the specified strength subject to the condition that only one out of three consecutive tests may give a value less than the specified strength but this shall not be less than 90% of the specified strength.

In the event that concrete tested in accordance with the requirements of this specification, fails to meet the requirement, the Engineer shall have the right to require any one or all the following.

1. Changes in the concrete mix proportions for the remaining work.
2. Curing and testing of the concrete represented by the tests which failed.
3. **Replacement of any such portions of the structure. (No payment for dismantled concrete, associated from worker or reinforcement shall be made. Embedded fixtures, reinforcement and adjoining structures, damaged during dismantling shall be made good by the Contractor at his own expense).**
4. Extended curing of the concrete represented by the specimen.
5. The contractor shall carry out all such measures as directed at his own expense.

Load tests of structural members may be required by the Engineer when the strength of the job control tests falls below the required strength and is not acceptable as per "Acceptance Criteria" stated earlier. The entire cost of the load test shall be borne by the Contractor. If the load testing is decided by the Engineer, the member under consideration shall be subjected to a superimposed

load equal to one and quarter (1.25) times the specified superimposed load used for design and this load shall be maintained for a period of 24 hours before removal.

The detailed procedure of the test shall be decided by the Engineer-in-charge.

If, within 24 hours of the removal of the load, the structure does not show a recovery of at least 75 percent of the deflection after the 24 hours under load, the test should be repeated. The structure should be considered to have failed to pass the test if the recovery after the second test is not at least 80 percent of the maximum deflection occurring during the second test.

If the member shows evident failure, such changes as are necessary to make the structure adequately strong, shall be made by the contractor free of cost to the Department. If on the other hand, the failure becomes apparent, the Engineer under special circumstances, can retain the portion of the structure under test, provided suitable strengthening and or load dispersed arrangement is feasible. Cost of such strengthening or load dispersed arrangement shall be borne by the Contractor.

Load test shall not be made until the expiry of 56 days of effective hardening of the concrete.

If a portion of the structure is found to be unacceptable it shall be dismantled and replaced by a fresh structure as per specification. The cost of such dismantling and reconstruction should be borne by the Contractor.

The proportions of cement, fine aggregate, coarse aggregate and water necessary to produce a concrete mix which will fulfill the requirements of this specification for each grade of concrete shall be determined on the basis of trial mixes conducted with the samples of the material to be used in the work by the Engineer-in-charge in the field Laboratory.

All mix design and test data and results shall be maintained as part of the record of the contract and shall be signed by the Engineer-in-charge and the Contractor. A register showing such record shall be maintained at site of work as shown below.

NAME OF WORK:

Sl. No.	Date & Time	Sample No.	No. of Cubes marks	Identifi- cation	Proportions of mix	Description of portion of work represented by sample and quantity of concrete represented by the sample	Initials of S.O/A.E. in whose presence sample is taken	Date of test		
(1)	(2)	(3)	(4)	(5)	(6)	(7)	(8)	(9)		

-										
7 days test result of each cube	Average 7 days strength	Standard 7 days strength	Date of test cube	28 days last result of each cube	Average 28 days strength	Standard 28 days strength	Remarks (the reference Nos. of test report should also be recorded here)	Review and Remarks by Asst. Engineer	Review and Remarks by Execu- tive Engineer	
(10)	(11)	(12)	(13)	(14)	(15)	(16)	(17)	(18)	(19)	

STRUCTURAL STEEL WORKS

1. Broadly, the work under this contract comprises of conveying of raw structural steel sections from BHEL Store to site fabrication shop, fabrication of steel work at the site fabrication shop including one priming coat of Zinc Chromate/red oxide primer, transportation of fabricated steel structures to the erection site including loading, unloading, leading, stacking as required and all handling costs, erection of steel work over prepared foundations or on RCC brackets as the case may be and painting of steel work two coats with approved synthetic enamel ready mixed paint or as specified in the Bill of quantities carrying from BHEL stores and erection of cloaking items etc. complete.
2. If found necessary, the tenderer may also be required to supply some raw structural steel sections also as required for this work in accordance with the latest editions of the Indian Standard Specifications: IS 2062 & IS 1977. He will be required to submit the necessary test certificates for the material so supplied for use on this work.
3. The detailed fabrication drawings as approved for fabrication will be the responsibility of BHEL. The Detailed Shop Drawings will be supplied by BHEL to the contractor progressively to suit the fabrication and erection sequence. The Contractor shall not depart from the drawings approved by BHEL without the written permission of the Engineer-in-charge.
4. Based on the detailed shop Drawings approved by the BHEL the Contractor shall prepare at his cost, the Drawing Office Dispatch Lists (abbreviated as D.O.D.L.'s) and get them approved by BHEL. These shall contain the drawing number, the designation of items, number of pieces, based on the section weights as adopted for supply of raw material without deduction for bolt holes and skew cuts. The DOD Lists shall form the basis for payment.
5. Rate quoted against item(s) of the Bill of Quantities cover the fabrication of all items involved and shall therefore be an Overall-average-rate. The actual quantities for payment shall be based on the drawing office dispatch lists to be prepared by the Contractor and got approved by BHEL as aforesaid.
6. All Civil works like preparation of foundations for columns, including embedding of holding down bolts etc., also have to be carried out and hence included in the present enquiry. All works shall be performed and completed in a thoroughly workmen like manner and the contractor shall follow the best modern practice in the manufacture of high grade structures not withstanding any omission in the specifications.
7.
 - a. Fabrication shall generally be in accordance with IS 800 (latest issue) entitled "Code of practice for use of structural steel in general building constructions". Welding shall be in accordance with IS 816 entitled "Code of practice for use of metal arc welding for general construction in mild steel". The contractor shall provide necessary splicing as approved by the Engineer-in-charge, to suit the available lengths of raw steel, and no extra amount shall be paid on this account. Any specifications not covered by the Relevant Indian Standard Codes of practice shall be in accordance with the relevant BS or in its absence in accordance with the well-established standard Engineering practice to be acceptable to BHEL.

- b. Under the contract, site fabrication is to be adopted for which a suitable site near and inside the factory premises will be made available by BHEL at free of "ground rent". The Contractor shall provide all plant and equipment, tools, covered sheds and other facilities required for site fabrication work at his own cost.
 - c. The Contractor shall take into consideration the existing foundation structures and make necessary provisions in the fabricated components with the approval of the Engineer-in-charge so that proper alignment, vertically and easy connection/ erection of structures is ensured. Should this involve any extra work on the part of the contractor beyond his normal scope, the same will be paid for, at mutually agreed rates.
8. All fabricated steel work shall be given one coat of Red Oxide/ Zinc Chromate primer conforming to Relevant IS code before erection. All fabricated steel work shall be match marked suitably to facilitate their erection in position without any difficulty.
 9. Material to be supplied by this organization will be supplied in standard/ random sizes/ lengths as stocked by BHEL. Hence the Contractor will be required to receive extra material to cover conversion, wastage, alteration etc. He shall do so without any claim for extra payment, whatsoever on this account.
 10. The Contractor should prepare in advance cutting lists for material so as to obtain efficient and economical use of all types of material including steel.
 11. Normally no night work will be permitted. But in case of emergency and urgency where night work is warranted, the Contractor shall arrange for night work providing all facilities including illumination at his own cost, after obtaining written permission from Engineer-in-charge under intimation to Security and Safety Departments.
 12. The Contractor shall closely scrutinize all the drawings for the work issued by this organization and bring to the notice of the Engineer-in-charge any discrepancies/ omissions noticed in the drawings before undertaking the actual work.
 13. M/s BHEL through their duly authorized representative shall have all reasonable times, access to the Contractor's premises or works and shall have the power at all reasonable times, to inspect any portion of the work or examine the material and workmanship of the structures during their manufacture and test. The Contractor shall give notice in writing to the inspecting Engineer of BHEL when the material to be supplied are ready for inspection and test, no material shall be used on the fabrication work until the inspecting Engineer has certified in writing that such materials have been inspected and approved by him. The contractor shall provide at his own cost all facilities for the required tests on fabricated structures as required by the Engineer-in-charge. Defective fabrication structures shall be made good/replaced by the Contractor at his own cost to the full satisfaction of BHEL. This also applies to loss or damage of raw material. The cost of special tests only will be borne by BHEL.
 14. Weekly progress reports shall be submitted giving in detail the position of receipt of raw material, progress of fabrication and completion of fabricated structures etc. The contractor shall submit at such times as may be requested by the Engineer-in-charge, schedules showing the program and order in which the Contractor proposes to carry out the fabrication and erection works with dates and estimated completion times for various portions of the work.

Such schedules shall be approved by the Engineer-in-charge prior to the starting of the relevant works.

15. BHEL would expect the contractor to take up simultaneously wherever possible both fabrication and erection of structures especially where a good deal of assembly work, which is in fact a continuation of the fabrication work, is required to be done at site. The painting and cloaking items of works, wherever possible, should be done simultaneously to save time. The Contractor may with the prior approval of BHEL sublet the work. The main contractor shall however, be responsible for all works executed on his behalf by the sub-contractors.

16. SETTING OUT AND ERECTION OF STEEL WORK:

- a) Erection of steel work shall generally be in accordance with the provision of IS 800 (Code of practice for use of structural steel in General Constructions).
- b) Site assembly of members on the ground by welding, bolting or otherwise as specified in shall be inspected thoroughly by the Engineer-in-charge, or his authorized representative and approved before erection.
- c) All equipment, facilities and consumables for site fabrication as well as erection plant requirement, etc., such as derricks, cranes, lifting tackles, wire ropes, chain pulley blocks, jacks, winches etc. as necessary shall be arranged for by the Contractor at his own cost. Care shall be taken to see that all equipment, tools & tackles, wire ropes etc. in use are always in good working conditions and fit for use. For all the tools and plants periodical calibration certificate from approved agency should be obtained. **The above lists should be enclosed before commencement of work.**
- d) Frames shall be lifted at such points that they will not buckle or deform. Trusses shall be lifted only at nodes. Temporary bracing shall, if required, be provided at no extra cost, to relieve erection stresses.
- e) In the case of trusses and similar roof structures all or at-least a majority of the purlins and wind bracings, shall be erected side by side with the erection of these structures. Columns shall be erected true to plumb, (screed bars should not be fixed separately over the prepared pedestals), true to center line, level and gauge of traveling cranes. Alignment of the columns, crane girders and rails shall be done very carefully using high precision survey instruments and necessary adjustments made to suit actual requirements. **A list of survey instruments proposed to be used shall be furnished before commencement of work.**
- f) All damages to the steel work caused during the transit or otherwise shall be made good to the full satisfaction of BHEL at Contractor's own cost, before erection.
- g) It shall be the sole responsibility of the Contractor to ensure accuracy of level, plumb, span and alignment of steel work before erection of other components.

17. PAINTING AFTER ERECTION:

- a) All steel work shall be given two coats of approved brands of first quality synthetic enamel ready mixed paint after erection (over the priming coat already provided). Painting shall be done as per IS 1477 (latest). The shade, make, quality and other particulars of the paint proposed to be used, shall be subject to prior approval by BHEL.
- b) It is the responsibility of the Contractor to procure sufficient quantities of the approved paints well in advance to ensure their availability in time.

18. TIME ALLOWED (Period of Contract)

The following program should be strictly followed.

Fabrication of structural steel works to be completed	:	Progressively from the date of award of work
Erection, painting of the above structures, supply and erection of cloaking items etc. to be completed	:	Progressively from the date on which completion of civil work and the readiness of site declared as fit for erection

- 19. The contractor will have to provide and fix the necessary templates etc. at his own cost in proper line, level and position to facilitate the erection work. Further, the contractor should lay and maintain necessary temporary approaches within his working areas at his own cost to facilitate his work and for easy movement of vehicles, cranes etc. deployed on the work. Only reasonable areas will be provided by BHEL.
- 20. Till the expiry of the maintenance period, (as specified in the tender) after the completion of the entire contract work and handing over to BHEL, the contractor should retain the minimum equipment and staff required and should carry out the maintenance works with the least possible interference to the routine works of the new shop. Till the expiry of the maintenance period the contractor shall be responsible for all damages occurring due to any fault on his part or on the part of his workmen, sub-contractor or other agencies engaged by him.
- 21. BHEL shall have the right to take possession of or use any completed or partially completed part of the work. Such possession or use shall not be deemed to be acceptance of any work not in accordance with the contract.
- 22. The contractor shall observe all safety regulations and take necessary safety precautions as called for under the Factories Act or other relevant statute as applicable including the use of safety boots, safety belts, helmets, other equipment and accessories for ensuring safe execution of the contract free from accidents.
- 23. The rates quoted in the Bill of Quantities of the tender for the fabrication item shall cover also the cost of preparation of DODL and similar incidental items. Fabrication works shall be undertaken only after the issue of approval of shop drawings.
- 24. The Contractor should co-operate with other contractors who may be executing their work in the same area in order to facilitate efficient execution of the entire project work in this area.

25. The Guarantee/ Warranty period for this contract shall be as specified in the tender, from the date of completion of the entire work and handing over to BHEL. During this period the successful tenderer shall be at site on his own expense for replacement or repair of all defects arising out of faulty material and/or workmanship.
26. Further particulars relating to design and fabrication and clarifications, if any, may be obtained on reference to the Head of the Department/ Civil- Factory, BHEL, PPPU/ Thirumayam or his nominee.
27. The contractor shall engage a level-II NDT Inspector for inspection of NDT works.
28. Inspection will be done by BHEL Staff/ Agencies appointed by BHEL for the works covered in the tender.
29. Painting, DFT of primer should be 25 microns.
30. Finish coat Painting, DFT 20 micron for each coat. Paint shall be of first quality; product of approved brand as per list of approved brands for material enclosed in the price bid.
31. Pre heating and post heating required shall be as per AWS (latest).
32. Welder qualification is to be done before commencement of the work and approved & qualified welder only shall be engaged in work. Necessary testing charges shall be borne by the contractor.
33. For the supply of material, the manufacturer's test certificate is to be produced.

GENERAL QUALITY CONTROL PROCEDURE FOR STRUCTURAL STEEL WORKS

The following quality standards are required to be maintained in all the structural steel fabrication components.

1. All the raw material will be generally conforming to IS 2062-latest or equivalent.
2. The welding electrodes shall be kept in oven only.
3. Submerged Arc welding has to be done for crane girder flange to web joints and built up column as per the details given in the approved drawings.
4. E7018 Welding electrode rods shall be used where the thickness of plates is 20mm and more and as specified in the drawings issued.
5. All the other weld in crane girder and butt welds in columns and beams shall be done with E 7018 welding electrodes.
6. All the welds in Nodal points of trusses and lattice girders shall be done with E 7018 welding electrodes.
7. Pre heating shall be done for plates having thickness 25mm & more and the temperature shall be maintained by checking with thermal chalk, as per quality standards.
8. All erection welding, of any component shall be done using E 7018 Welding Electrode.
9. 100% visual check shall be carried out for raw material and welding on all components and the welding areas during inspection, to be tested for LPI/ MPI/ UT/ Radiography/ PWHT as provided in the Quality Control Procedure.
10. Base plate to column shall be perfectly checked for perpendicularity.
11. All the components shall be checked for dimension at fit-up stage itself before the commencement of welding operation.
12. Contractor shall buy & use Black Hex. bolts and nuts as per IS Specifications as detailed below for fabrication & erection of steel structures.
 - a) Black Hex Bolts IS 1363 - 1984 Part – I (Class 5.6/5.8)
 - b) Black Hex Nuts IS 1363 - 1984 Part - III
 - c) Plain MS washer IS 2016 - 1975
 - d) Taper washer for beams IS 5274 - 1975
 - e) Taper washer for channel IS 5372 - 1975
 - f) Spring washer IS 3063 - 1964
13. Contractor shall buy & use the following welding consumables as detailed below:

a)	SMAW	Electrodes	Manufacturer
		No.	
	1.	E 6013 & E 7018	D & H Secheron
	2.	E 6013 & E 7018	ESAB India Ltd.
	3.	E 6013 & E 7018	Modi Arc Electrode Co.
	4.	E 6013 & E 7018	D & H Welding Electrode (I) Ltd.
	5.	E 6013 & E 7018	MantekElectrodes (P) Ltd.
	6.	E 6013 & E 7018	Ador Welding Ltd.
	7.	E 6013 & E 7018	Varun Electrodes Pvt. Ltd.

b) SAW Wire

Sl.No.	Brand	Manufacturer
1.	AUTO melt Grade A	Ador Welding
2.	Mantek Grade A	Mantek Wires
3.	Metaspool S1 dia. 4mm	Precision Wires
4.	OK Aut Rod 12.08 L	ESAB India Ltd.

c) Flux

Sl.No.	Brand	Manufacturer
1.	Super S41	Super Elec Inds
2.	Mantek 22	Mantek Welded Flux Co.
3.	RMH Auto Weld Grade 1	RMH Chemicals
4.	SWP 40 T	Super Weld Prod

d) GMAW (CO2)

Electrode	Brand	Manufacturer
ER70S-6 Co2 WIRE	Automig-1	Ador Welding Ltd.
ER70S-6 Co2 WIRE	Esab MW1	Esab India Ltd., Chennai
ER70S-6 Co2 WIRE	MantekMig	MantekWiress
ER70S-6 Co2 WIRE	Nouvarc	Nouveax Industries (P) Ltd., Kangayam
ER70S-6 Co2 WIRE	Autofil-6	Voltrac Electrode Pvt. Ltd., Tirupathi.
ER70S-6 Co2 WIRE	Prima Mig/Mag	Varun Electrodes Pvt. Ltd., Panipat.

14. Rolled steel sections of depth greater than 450mm need to be visually checked for lamination before the process of fabrication. The doubtful area is to be tested and if lamination is found UT Test to be carried-out.
15. The welding code of practice, procedures, specifications for electrodes/ consumables etc., for manual welding and auto welding shall conform to AWS D1.1/D1.1M:2006 (Latest) and as per the component-wise QCP issued by BHEL.
16. All the fabrication and erection works shall have to be executed as per the QCP approved by BHEL.
17. All the fabrication and erection works will be inspected for Quality Control by a third party inspection agency as fixed by BHEL.

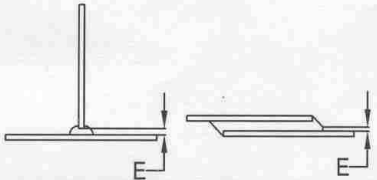
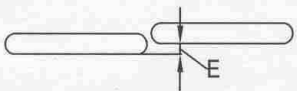
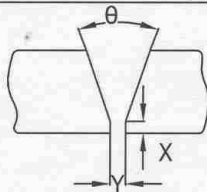
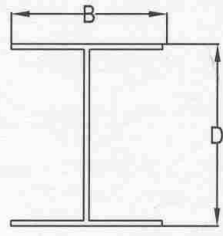
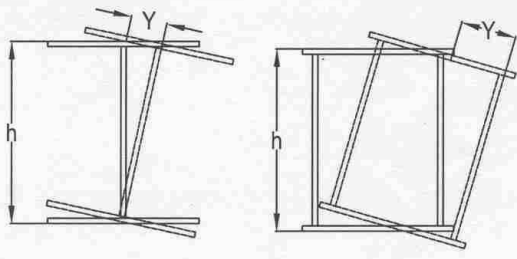
DESIGNATION	DETAIL OF SKETCH	PERMISSIBLE DEVIATION
FILLET WELD FIT UP	FIG:2 	MAX.LOCALISED GAP =1.5mm
BUTT WELD	FIG:3 	CUT OF ALIGNMENT = 3 mm MAX
FIT UP	FIG:4 	FOR ,X,Y, θ REFER =1.2 &3 OF CL 7:4:3
SECTION SIZE	FIG:5 	D: UPTO 1M : ± 3mm 1M TO 2M : ± 4.5mm OVER 2M : + 7.5 mm - 4.5mm B:±3mm
TWIST ON SECTION (Y)		$Y=0.005h$ 10 mm MAX

LINE OF FLAME HEATING

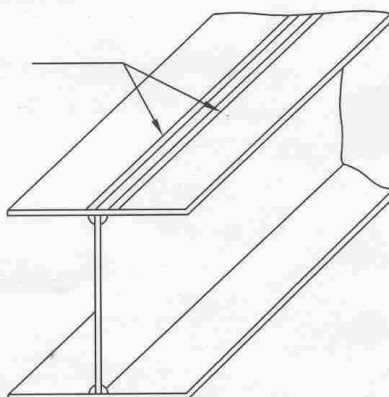

FIG:1

CORRECTION OF FLANGE WARPAGE

DESIGNATION	DETAIL OF SKETCH	PERMISSIBLE DEVIATION
WEB SHIFT	<p>FIG:2</p> <p>A 2D cross-section of an I-beam. The top flange has a total width labeled 'B'. The web is centered. The distance from the center of the web to the left edge of the top flange is labeled 'b1', and the distance to the right edge is labeled 'b2'.</p>	$\frac{b1 - b2}{2} = 2\text{mm}$
FLANGE WARPAGE	<p>FIG:3</p> <p>A 2D cross-section of an I-beam. The top flange has a total width labeled 'B'. The top edge of the flange is curved upwards. The maximum upward deviation from the original flat line is labeled 'T1'. The bottom edge of the flange is curved downwards. The maximum downward deviation from the original flat line is labeled 'T2'.</p>	$T1+T2 = \frac{B}{100} \text{ OR } 6\text{MM}$

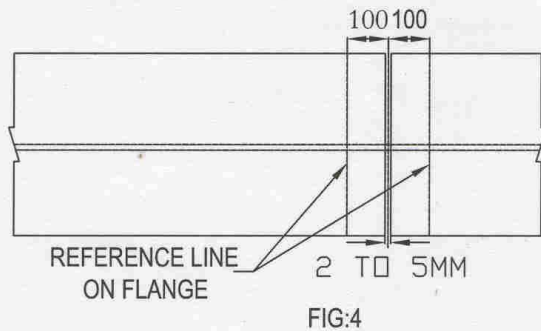
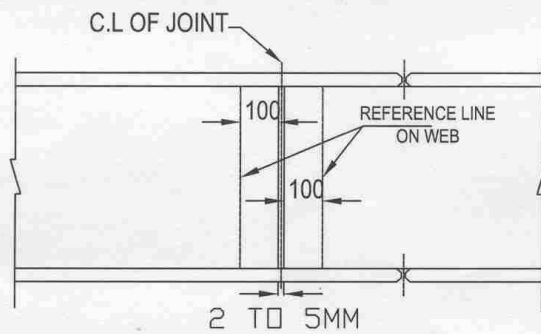
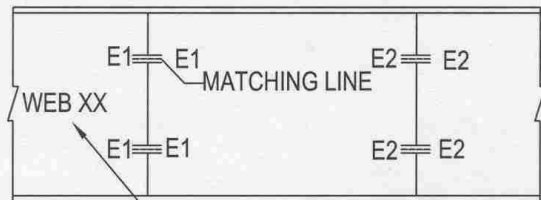
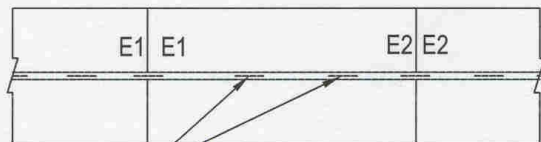

FIG:5 MATCH MARKING [GIRDER-5]



POSITION OF ALL WELDED BEAMS TO BE MARKED ON THE WEB

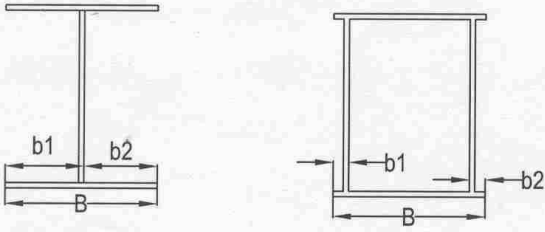
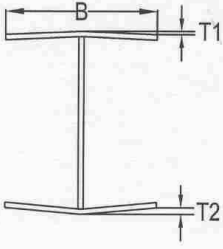
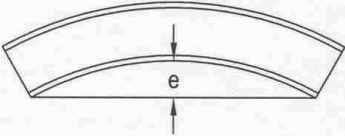

CENTRE LINE PUNCHING OF FLANGE AT INTERVALS OF EVERY TWO METERS

DESIGNATION	DETAIL OF SKETCH	PERMISSIBLE DEVIATION
WEB SHIFT	<p>FIGURE-7</p> 	$\frac{b1 - b2}{2} = 2\text{mm MAX}$
FLANGE WARPAGE	<p>FIGURE-8</p> 	$T1 + T2 = \frac{B}{100} \text{ OR } 6\text{MM}$
CAMBER	<p>FIGURE-9</p> 	$E = \frac{1}{1000} \times \text{length}$ <p>SUBJECT TO MAX] OF 10mm.</p>

A

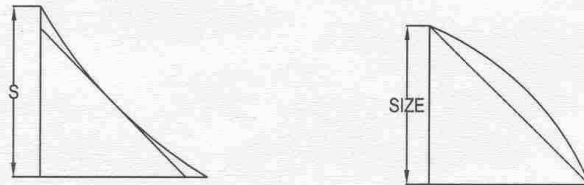

DESIRABLE FILLET WELD PROFILE

B

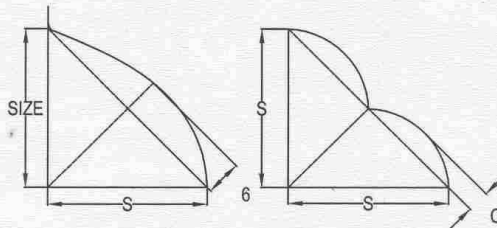

ACCEPTABLE FILLET PROFILE CONVEXITY SHALL NOT EXCEED 0.15 + 0.03IN

C

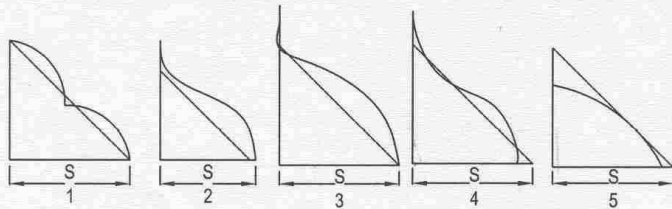

DEFECTIVE FILLET WELD PROFILE

D

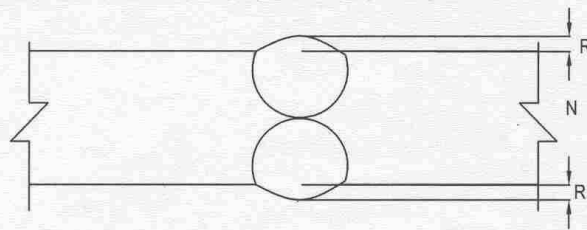

ACCEPTABLE BUTT WELD PROFILE REINFORCEMENT SHALL NOT EXCEED $\frac{1}{8}N$

E

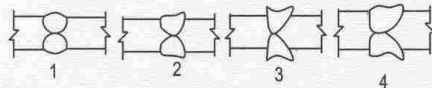

DEFECTIVE BUTT PROFILES

ACCEPTABLE AND WELD PROFILES

- | | |
|-----------------------------|-----------------------------|
| C1-INSUFFICIENT WELD THROAT | E1-EXCESSIVE CONVEXITY |
| C2-EXCESSIVE CONVEXITY | E2-INSUFFICIENT WELD THROAT |
| C3-EXCESSIVE UNDER CUT | E3-EXCESSIVE UNDER CUT |
| C4-OVER LAP | E4-OVER LAP |
| C5-IN SUFFICIENT LEG | |

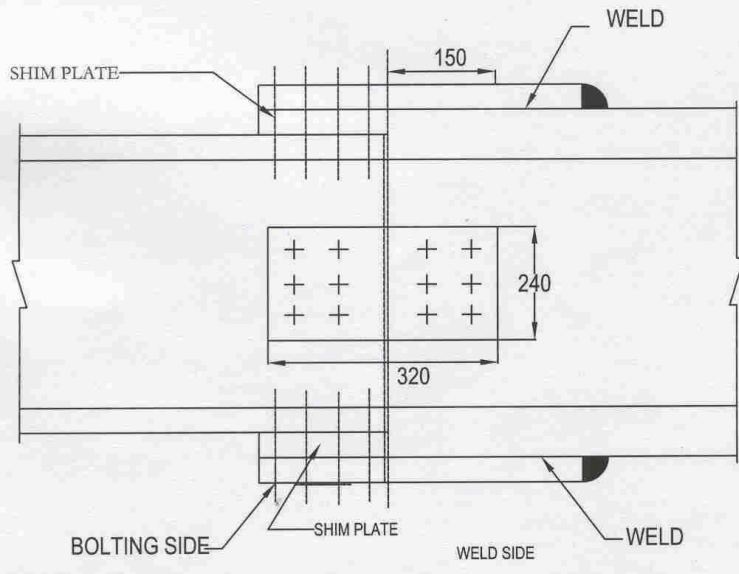

WHEN BOLTING SIDE IS OF LOWER SECTION USE SHIMS

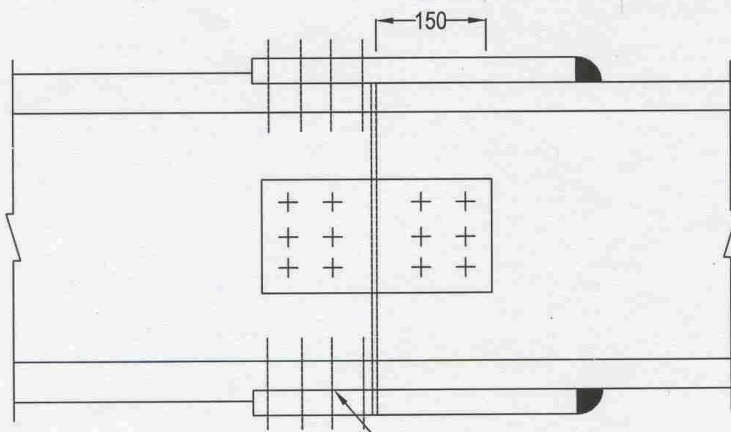

BUTT PLATE
WHEN BOLTING
SIDE IS OF
HIGHER SECTION

BOLTED TYPE COLUMNS
(W.F. SECTION)

ANNEXURE - VI

BHARAT HEAVY ELECTRICALS LIMITED

TIRUCHIRAPPALLI – 620 014

CIVIL ENGINEERING DEPARTMENT

**BHEL
SCHEDULE OF RATES
2013-14**

BASED ON CPWD ANALYSIS OF RATES

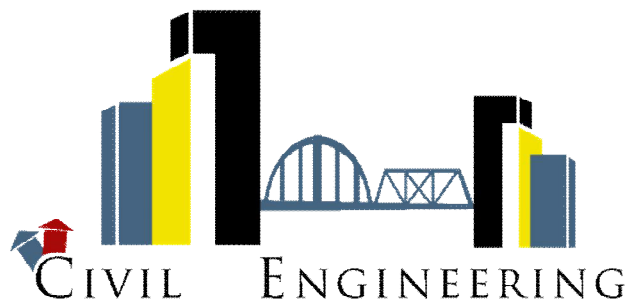

PREFACE

1. BHEL Schedule of Rates 2013-14 has been prepared based on TN PWD 2013-14, CPWD Analysis of DSR 2013, Highways SR 2014.
2. Labour wages are as per State PWD Schedule of Rates. Rate for most of materials are adopted from least rates collected in local market. The remaining material rates are taken from TN PWD SR 2013-14 & DSR 2013.
3. Cement, Reinforcement Steel & Structural Steel required for the works will be issued by BHEL Stores at free of cost.
4. Water, Power and Compressed air required for the works will be provided by this organization at free of cost at only one point, subject to availability. In case of failure of the above provisions, contractor has to make his own arrangements for water without any extra claim.
5. All the item rates in this S.R includes :-
 - i) 13.61% of labour wage towards contractor's contribution for P.F.
 - ii) 4.75% of labour wage towards contractor's contribution for ESI.
 - iii) 10 % towards contractor's profit & overheads.
 - iv) No additional payment as insisted by BHEL is included in SR.
6. A floor means a floor of maximum height of 4.50 metre.
7. Items of work not finds place in this Schedule of Rates and if required later will be included as and when necessary.
8. This Schedule of Rates 2013–14 has the financial concurrence and approval of competent authority.

* * * * *

NEW ITEMS ADDED IN SR 2013-14

S.No	Item No	Description
1	103 A to D	Open Excavation
2	126	Injecting pre-const anti-termite treat
3	128A	Injecting-post-const anti-termite treat along external wall where apron not provided
4	128B	Injecting-post-const anti-termite treat along external wall or apron
5	128C	Injecting-post-const anti-termite treat for soil under flooring
6	128D	Injecting-post-const anti-termite treating existing masonry
7	128E	Injecting-post-const anti-termite treat at wook work
8	201H	PCC 1:4:8 20mm upto Plinth
9	320	Brick flyash lime
10	321	Brick FALG
11	431A	uPVC Door frame 48X40
12	431B	uPVC Door frame 42X50
13	432	PVC door shutter 24mm tk
14	433	PVC door shutter 30mm tk
15	434	PVC flush door shutter 25 mm tk
16	435	P.V.C. door frame 50x47 mm
17	436A	PVC foam door shutter 30 mm tk- non decorative
18	436B	PVC foam door shutter 30 mm tk- decorative
19	438A	Removing the existing Teakwood partition partly panelled with door
20	438B	Removing the existing Teakwood partition panelled with door
21	439A	Fixing Teakwood partition partly panelled, glazed with door
22	439B	Fixing Teakwood partition panelled, glazed with door
23	546	UV resistant polyurethane compound lining
24	547	UV resistant polyurethane compound lining with removing and fixing North light Glazing, roofing sheets
25	548	Paver block coloured 50mm tk
26	549	Welding & erecting 90 Lbs/CR 80 Rail
27	550	Renewing the bottom rail and/or top rubber of collapsible gate
28	552	Cup type Rail Clamp
29	553	Erection of CR 80/R 45 rails at all heights
30	612B	Plain Ceramic Tiles of 305mm X 305mm X 6mm of all Colours
31	612C	First Quality Design Ceramic tile of Size 305mm X 305mm X 6mm of all Colours.
32	616	Ceramic glazed wall tiles laid over 20 mm tk Cemenr Mortar 1:3

S.No	Item No	Description
33	618L	Floor - Granite slab 16-18mm green
34	618O	Floor - Granite slab 16-18mm Blue
35	618P	Floor - Granite slab 16-18mm Lakha red
36	619I	Granite tiles-8 - 10mm Raw silk
37	619J	Granite tiles-8 - 10mm Steel grey
38	620A	Stone tile work of 8 mm thick Mirror Polished - Jet Black
39	620B	Stone tile work of 8 mm thick Mirror Polished - Red (Gem) Colour
40	620C	Stone tile work of 8 mm thick Mirror Polished - Green Colour
41	620D	Stone tile work of 8 mm thick Mirror Polished - Black (Galaxy) Colour
42	620E	Stone tile work of 8 mm thick Mirror Polished - Steel Grey Colour
43	620F	Stone tile work of 8 mm thick Mirror Polished - Rajnagar plain white/Green (Udaipur)/Black (Zebra)
44	621A	Stone tile work of 8 mm thick polished - Jet Black
45	621B	Stone tile work of 8 mm thick Polished - Red (Gem) Colour
46	621C	Stone tile work of 8 mm thick Polished - Green Colour
47	621D	Stone tile work of 8 mm thick Polished - Black (Galaxy) Colour
48	621E	Stone tile work of 8 mm thick Polished - Steel Grey Colour
49	621F	Stone tile work of 8 mm thick Polished - Rajnagar plain white/Green (Udaipur)/Black (Zebra)
50	627	Labour charges for Nozing & Polishing
51	628	Flooring with 1:2:4 using 20mm
52	701	Carrying hoisting and fixing Al Zn alloy coated roofing sheets
53	702	Carrying hoisting and fixing Al Zn alloy coated sidesheets
54	703	Supplying, Conveying hoisting and fixing Al Zn alloy coated roofing sheets
55	704	Supplying, conveying, hoisting and fixing Al Zn alloy coated sidesheets
56	705	Supplying fixing 2mm Poly carbonate sheets
57	706	Supplying and fixing Turbo Air Ventilators of 600mm dia or thereabouts
58	723	Conveying fixing 4mm/6mm thick polycarbonate sheet for north light glazing
59	724	Collecting and cleaning damaged north light glazing sheets
60	840A	ACE paint 3 coats
61	841A	ACE 3 coat on stucco /Ex.aggr. Surface
62	846	Altek superfine 2 coat
63	903 TO 921	Road Specifications
64	1107C	160x160x160mm single tee with door

S.No	Item No	Description
65	1107F	160x160x160mm single tee without door
66	1107L	160mm bend
67	1110iii	CP brass long body bib cock -15mm
68	1115 ii	Brass chromium plated towel rail 600 mm
69	1115 iii	Anodised aluminium Towel rail 60cm long
70	1116ii	Circular shape 450 mm dia Mirror
71	1116 iii	Rectangular shape 453x357 mm Mirror
72	1116 iv	Oval shape 450x350 mm Mirror
73	1116 v	Rectangular shape 1500x450 mm Mirror
74	1130 ii	Urinal size 580x380x350 mm
75	1152a	Labour - GI fitting 15mm
76	1152b	Labour - GI fitting 20mm
77	1152c	Labour - GI fitting 25mm
78	1152d	Labour - GI fitting 32mm
79	1152e	Labour - GI fitting 40mm
80	1152f	Labour - GI fitting 50mm
81	1152g	Labour - GI fitting 65mm
82	1152h	Labour - GI fitting 80mm
83	1152i	Labour - GI fitting 100mm
84	1152j	Labour - GI fitting 125mm
85	1152k	Labour - GI fitting 150mm
86	1153i	Gun metal valve 25mm (horizontal)
87	1153ii	Gun metal valve 25mm (vertical)
88	1153iii	Gun metal valve 32mm (horizontal)
89	1153iv	Gun metal valve 32mm (vertical)
90	1153v	Gun metal valve 40mm (horizontal)
91	1153vi	Gun metal valve 40mm (vertical)
92	1153vii	Gun metal valve 50mm (horizontal)
93	1153viii	Gun metal valve 50mm (vertical)
94	1153 ix	Gun metal valve 65mm (horizontal)
95	1153x	Gun metal valve 65mm (vertical)
96	1153xi	Gun metal valve 80mm (horizontal)
96	1153xii	Gun metal valve 80mm (vertical)
97	1154	CP bottle trap 32mm dia.
98	1155	Polyethylene cylindrical tank 500 litres

S.No	Item No	Description
99	1156	Fire clay laboratory sink (white)
100	1157	white glazed earthen ware wash hand basin of oval shape
101	1158	PTMT float valve
102	1159	Labour for removing blockage in gully trap
103	1210a	False ceiling- Arm Gyp
104	1210b	False ceiling-Aruba
	1218	Servicing aluminium door/window
105	1219 A to H	Aluminium Grill
106	1220	Powder coated Al.Partition for 3.2m ht- Partially panelled
107	1221	Powder coated Al.Partition for 3.2m ht- fully panelled
108	1222	Powder coated Al.Partition for 1.5 m ht- Partially panelled
109	1223	Powder coated Al. single leaved/double leaved
110	1224	Powder coated al. ventilator
111	1225	Powder coated Al. two track sliding window
112	1226	Anodised Al.Partition for 3.2m ht- Partially panelled
113	1227	Anodised Al.Partition for 3.2m ht- fully panelled
114	1228	Anodised Al.Partition for 1.5 m ht- Partially panelled
115	1229	Anodised Al. single leaved/double leaved
116	1230	Anodised al. ventilator
117	1231	Anodised Al. two track sliding window
118	1232 a to b	False ceiling 7.5mm Nano Tiles 600X600, 4mm Everest Tiles 600X600
119	1235	Vertical Venetian Blinds
120	1302A	Boring - 300mm dia.
121	1302B	Boring - 400mm dia.
122	1302C	Boring - 450mm dia.
123	1533	Labour - Chain link fence
124	1534A	G.I Chain link fencing 50 X50
125	1534B	PVC coated G.I Chain link fencing
126	1535	G.I Chain link fencing 25X25
127	1536A to D	Drilling of Holes
128	1537	Cleaning of septic tank
129	1538	Roof leak-1 primer coat
130	1539	Roof leak-1 primer and 2 top coats
131	1540	2 membrane coats and 1 bond coat

S.No	Item No	Description
132	1541	Crack filling at parapet level with pressure grouting
133	1542	Crack filling at parapet level without pressure gouting
134	1543	Drilling pockets and fixing PVC Nipples in position
135	1544	Providing one coat of Antifungal coating
136	1545	Arresting leakage through RCC Construction joints
137	1546	Arresting leakage through Masonry consruction joints.
138	1547	Providing aluminum Sheet Flashing

CONTENTS

CHAPTER No.	TITLE	PAGE No.
I	EARTHWORK	1
II	CONCRETE WORKS	8
III	MASONRY WORKS	14
IV	WOOD WORKS	17
V	STEEL WORKS	26
VI	FLOORING	36
VII	ROOFING	43
VIII	FINISHING	49
IX	ROAD WORKS	56
X	DISMANTLING AND DEMOLITION	62
XI	WATER SUPPLY AND SANITARY ITEMS	64
XII	ALUMINIUM WORKS, FALSE CEILING ETC.	78
XIII	PILE WORKS	89
XIV	HORTICULTURE	90
XV	MISCELLANEOUS	93

I - EARTHWORK

Item No.	Description	Unit	Rate (Rs.P)
0101	Earthwork excavation (TRENCHES) in soils given below by mechanical means (Hydraulic excavator)/manual means and depositing the excavated earth at suitable places within the initial lead of 50 meter and initial lift of 1.5 meter for foundation in building works, roads, narrow drains, sewers, bridges, pipe lines etc., sectioning the subgrade to proper level and grade, watering and consolidating the subgrade to receive concrete bed, all as per standard specifications and instructions of Engineer-in-charge.		
A	All kinds of soil except rock	CUM	125.80
B	Ordinary rock	CUM	201.70
C	Hard rock (requiring blasting)	CUM	363.55
D	Hard rock (blasting prohibited)	CUM	410.75
0102	Earthwork excavation (TRENCHES) in soils given below by mechanical means (Hydraulic excavator)/manual means and depositing the excavated earth at suitable places within the initial lead of 50 meter and initial lift of 1.5 meter for foundation in building works, roads, narrow drains, sewers, bridges, pipe lines etc., sectioning the subgrade to proper level and grade, watering and consolidating the subgrade to receive concrete bed, all as per standard specifications and instructions of Engineer-in-charge. <u>Rate also includes bailing or pumping out water during excavation due to subsoil water, rain etc.</u>		
A	All kinds of soil except rock	CUM	138.40
B	Ordinary rock	CUM	221.85
C	Hard rock (requiring blasting)	CUM	399.90
D	Hard rock (blasting prohibited)	CUM	451.80
0103	Earth work for Open excavation (exceeding 30 cm in depth, 1.5 m in width as well as 10 sqm on plan) in soils given below by mechanical means (Hydraulic excavator)/manual means including disposal of earth at suitable places within a lead upto 50 metres and lift upto 1.5 metre, sectioning the subgrade to proper level and grade. Disposed soil are to be leveled and neatly dressed.		
A	All kinds of soil except rock	CUM	178.10
B	Ordinary rock	CUM	188.55
C	Hard rock (requiring blasting)	CUM	334.30
D	Hard rock (blasting prohibited)	CUM	400.90
0104	Earth work in surface excavation not exceeding 30 cm in depth but exceeding 1.5 m in width as well as 10 sqm on plan including disposal of excavated earth upto 50 m and lift upto 1.5 m, disposed soil to be levelled and neatly dressed in All kinds of soil	SQM	35.40

Item No.	Description	Unit	Rate (Rs.P)
0105	Surface dressing of the ground in all kinds of soil (excluding rock) including removing vegetation and inequalities not exceeding 15cm deep and disposal of rubbish, lead upto 50 m and lift upto 1.5 m.	SQM	8.70
0106	Open timbering in trenches including strutting and shoring complete. (Measurements to be taken of the face area timbered)		
A	Depth not exceeding 1.5 metre	SQM	52.25
B	Depth exceeding 1.5 metre but not exceeding 3 metre	SQM	55.20
C	Depth exceeding 3 metre but not exceeding 4.5 metre	SQM	60.10
0107A	Extra for Earthwork excavation (TRENCHES) in soils given below by mechanical means (Hydraulic excavator)/manual means and depositing the excavated earth at suitable places within the initial lead of 50 meter and initial lift of 1.5 meter for foundation in building works, roads, narrow drains, sewers, bridges, pipe lines etc., sectioning the subgrade to proper level and grade, watering and consolidating the subgrade to receive concrete bed, all as per standard specifications and instructions of Engineer-in-charge. In or under water and/ or liquid mud, including pumping out water as required.		
(i)	All kinds of soil except rock	CUM	25.15
(ii)	Ordinary rock	CUM	40.35
(iii)	Hard rock (requiring blasting)	CUM	72.70
(iv)	Hard rock (blasting prohibited)	CUM	82.15
	Extra for Earth work for Open excavation (exceeding 30 cm in depth, 1.5 m in width as well as 10 sqm on plan) in soils given below by mechanical means (Hydraulic excavator)/manual means including disposal of earth at suitable places within a lead upto 50 metres and lift upto 1.5 metre, sectioning the subgrade to proper level and grade. Disposed soil are to be levelled and neatly dressed. In or under water and/ or liquid mud, including pumping out water as required.		
(v)	All kinds of soil except rock	CUM	35.60
(vi)	Ordinary rock	CUM	37.70
(vii)	Hard rock (requiring blasting)	CUM	66.85
(viii)	Hard rock (blasting prohibited)	CUM	80.20
(ix)	Extra for earth work in surface excavation not exceeding 30 cm in depth but exceeding 1.5 m in width as well as 10 sqm on plan including disposal of excavated earth upto 50 m and lift upto 1.5 m, disposed soil to be levelled and neatly dressed. All kinds of soil in or under water and/ or liquid mud, including pumping out water as required	SQM	7.10
(x)	Extra for Surface dressing of the ground in all kinds of soil (excluding rock) including removing vegetation and inequalities not exceeding 15cm deep and disposal of rubbish, lead upto 50 m and lift upto 1.5 m in or under water and/ or liquid mud, including pumping out water as required.	SQM	1.75

Item No.	Description	Unit	Rate (Rs.P)
0107B	Extra for Earthwork excavation (TRENCHES) in soils given below by mechanical means (Hydraulic excavator)/manual means and depositing the excavated earth at suitable places within the initial lead of 50 meter and initial lift of 1.5 meter for foundation in building works, roads, narrow drains, sewers, bridges, pipe lines etc., sectioning the subgrade to proper level and grade, watering and consolidating the subgrade to receive concrete bed, all as per standard specifications and instructions of Engineer-in-charge. In or under foul position, including pumping out water as required.		
(i)	All kinds of soil except rock	CUM	31.45
(ii)	Ordinary rock	CUM	50.45
(iii)	Hard rock (requiring blasting)	CUM	90.90
(iv)	Hard rock (blasting prohibited)	CUM	102.70
	Extra for Earth work for Open excavation (exceeding 30 cm in depth, 1.5 m in width as well as 10 sqm on plan) in soils given below by mechanical means (Hydraulic excavator)/manual means including disposal of earth at suitable places within a lead upto 50 metres and lift upto 1.5 metre, sectioning the subgrade to proper level and grade. Disposed soil are to be leveled and neatly dressed. In or under foul position, including pumping out water as required.		
(v)	All kinds of soil except rock	CUM	44.55
(vi)	Ordinary rock	CUM	47.15
(vii)	Hard rock (requiring blasting)	CUM	83.60
(viii)	Hard rock (blasting prohibited)	CUM	100.25
(ix)	Extra for earth work in surface excavation not exceeding 30 cm in depth but exceeding 1.5 m in width as well as 10 sqm on plan including disposal of excavated earth upto 50 m and lift upto 1.5 m, disposed soil to be levelled and neatly dressed All kinds of soil in or under foul position, including pumping out water as required.	SQM	8.85
(x)	Extra for Surface dressing of the ground in all kinds of soil (excluding rock) including removing vegetation and inequalities not exceeding 15cm deep and disposal of rubbish, lead upto 50 m and lift upto 1.5 m in or under foul position, including pumping out water as required.	SQM	2.20
	Note :- The extra percentage is applicable in respect of each item, but limited to quantities of work done in these difficult conditions. The unit, namely , metre depth, to be considered for payment, shall be the depth measured from the sub soil water level upto the centre of gravity of the quantity executed in difficult conditions. The depth shall be reckoned correct to 0.10 metre, 0.05 metre or more shall be taken as 0.10 metre and less than 0.05 metre ignored.		
0108	Extra for every additional lift of 1.5 metre or part thereof in :		
A	All kinds of soil Excluding Rock.	CUM	32.45
B	Ordinary or hard rock	CUM	58.20

Item No.	Description	Unit	Rate (Rs.P)
0109	Extra for every additional lead of 10 metre or part thereof over the initial lead for all kinds of soil.	CUM	32.45
0110	Supply and filling with river sand in foundation, plinth, under floor etc. including watering, ramming, consolidating and dressing complete.	CUM	502.95
0111	Supply and spreading/filling with stone dust complying with standard specifications.	CUM	250.40
0112	Filling available excavated earth (excluding rock) in trenches, plinth, sides of foundation etc. in layers not exceeding 20 cm in depth, consolidating each deposited layer by ramming and watering, lead upto 50 m and lift up to 1.5 m etc. complete.	CUM	78.90
0113	Labour charges for mixing the earth, red earth, sand, manure, coconut waste etc. thoroughly to the required proportion and carrying the same and filling it in the excavated pits/areas at various locations with all leads and lifts. Rate excludes cost of materials.	CUM	85.90
0114	Ploughing the existing ground in all kinds of soil to a depth of 15 to 25 cm and watering the same.	SQM	8.85
0115	Labour charges for breaking clods, consolidating, sectioning etc.	CUM	2.90
0116	Forming turving in slopes with initial watering, all as per instructions of Engineer-in-charge.	SQM	16.15
0117	Extra rate for consolidation of bunds etc. by means of the following, including watering.		
A	Hand roller	CUM	9.65
B	Power roller including hire charges.	CUM	16.15
0118	Benching hard rock upto an average 10 cm depth	SQM	315.70
0119	Drilling holes in hard granite/RCC structure:		
A	45 mm dia	RM	123.70
B	50 mm dia	RM	147.35
C	75mm dia	RM	167.35
0120	Bailing or pumping out water from trenches, foundations etc., at all depths wherever necessary as per standard specifications.	HP/Hr	65.05
0121	Clearing grass and removal of rubbish upto a distance of 50 metre.	SQM	2.30

Item No.	Description	Unit	Rate (Rs.P)
0122	Clearing jungle including uprooting of rank vegetation, grass, brushwood, trees and saplings of girth upto 30 cm measured at a height of 1 metre above ground level and removal of rubbish upto a distance of 50 metre.	SQM	4.50
0123	Felling trees of girth (measured at a height of 1 metre above ground level) including cutting of trunks and branches, removing the roots from the soil and then filling the pit and depression, stacking of serviceable materials and disposal of unserviceable materials.		
A	Beyond 30 cm girth upto and including 60 cm girth	EACH	139.20
B	Beyond 60 cm girth upto and including 120 cm girth	EACH	613.65
C	Beyond 120 cm girth upto and including 240 cm girth	EACH	2831.15
D	Above 240 cm girth	EACH	5682.55
0124	Supplying Chlorpyrifos / Lindane emulsifiable concentrate of 20 % (chemical emulsion) in sealed containers at site of work.	LITRE	176.10
0125	Labour charges for pre-constructional anti-termite treatment by diluting and injecting chemical emulsion which will be supplied by BHEL at free of cost and creating a continuous chemical barrier under and around the column pits, wall trenches, basement excavation, top surface of plinth filling, junction of wall and floor, along the external perimeter of building, expansion joints, over the top surface of consolidated earth, surrounding of pipes and conduits etc. complete , all as per standard specification. (Plinth area of building at ground floor only shall be measured for payment)	SQM	142.65
0126	Diluting and injecting pre-constructional anti-termite treatment by chemical emulsion and creating a continuous chemical barrier under and around the column pits, wall trenches, basement excavation, top surface of plinth filling, junction of wall and floor, along the external perimeter of building, expansion joints, over the top surface of consolidated earth, surrounding of pipes and conduits etc. complete , all as per standard specification. (Plinth area of building at ground floor only shall be measured for payment). Rate includes cost of Chemical emulsion, labour charges and all other incidentals etc as per instructions of Engineer in charge.	SQM	477.25
0127	Labour charges for post-constructional anti-termite treatment by diluting and injecting chemical emulsion (will be supplied by BHEL at free of cost), all as per standard specification.		
A	Along external wall where the apron is not provided using chemical emulsion @ 7.5 litres / sqm of the vertical surface of the substructure to a depth of 300 mm including excavation channel along the wall & rodding etc. complete.	RM	11.35
B	Along the external wall below concrete or masonry apron using chemical emulsion @ 2.25 litres per linear metre including drilling and plugging holes etc.	RM	17.40

Item No.	Description	Unit	Rate (Rs.P)
C	Treatment of soil under existing floors, using chemical emulsion @ one litre per hole, 300 mm apart including drilling 12 mm dia holes and plugging with cement mortar 1:2 (1 cement : 2 coarse sand) to match the existing floor. (Requirement of chemical emulsion - Chlorpyriphos/Lindane E.C 20 % with 1 % concentration - 5 litre / 9 SQM)	SQM	90.60
D	Treatment of existing masonry using chemical emulsion @ one litre per hole at 300 mm interval including drilling holes at 45 degree and plugging them with cement mortar 1:2 (1 cement : 2 coarse sand) to the full depth of the hole. (Requirement of chemical emulsion - Chlorpyriphos/Lindane E.C 20 % with 1 % concentration - 1.70 litre / 10 RM)	RM	13.50
E	Treatment at points of contact of wood work by chemical emulsion Chlorpyriphos/Lindane (in oil or kerosene based solution) @ 0.50 litre per hole by drilling 6 mm dia holes at downward angle of 45 degree at 150 mm centre to centre and sealing the same. Rate includes cost of kerosene but excludes chemical. (Requirement of chemical emulsion - Chlorpyriphos/Lindane E.C 20 % with 1 % concentration - 1.70 litre / 10 RM)	RM	123.80
0128	Diluting and injecting chemical emulsion (BIFLEX T.C 2.5 EC in 20 L/Equivalent) for post-constructional anti-termite treatment, all as per standard specification. Rate includes cost of Chemical emulsion, labour charges and all other incidentals etc as per instructions of Engineer in charge.		
A	Along external wall where the apron is not provided using chemical emulsion @ 7.5 litres / sqm of the vertical surface of the substructure to a depth of 300 mm including excavation channel along the wall & rodding etc. complete.	RM	66.30
B	Along the external wall below concrete or masonry apron using chemical emulsion @ 2.25 litres per linear metre including drilling and plugging holes etc.	RM	72.35
C	Treatment of soil under existing floors, using chemical emulsion @ one litre per hole, 300 mm apart including drilling 12 mm dia holes and plugging with cement mortar 1:2 (1 cement : 2 coarse sand) to match the existing floor.	SQM	361.95
D	Treatment of existing masonry using chemical emulsion @ one litre per hole at 300 mm interval including drilling holes at 45 degree and plugging them with cement mortar 1:2 (1 cement : 2 coarse sand) to the full depth of the hole.	RM	96.55

Item No.	Description	Unit	Rate (Rs.P)
E	Treatment at points of contact of wood work by chemical emulsion (in oil or kerosene based solution) @ 0.50 litre per hole by drilling 6 mm dia holes at downward angle of 45 degree at 150 mm centre to centre and sealing the same. Rate includes cost of kerosene, chemical emulsion.	RM	206.80
0129	Hire charges for engaging earth moving machinery (Hydraulic Excavator) to attend to channeling works at river bed, pipe line burst works, cleaning the areas including uprooting thorny plants/heavy jungles/trees etc.of all heights and leveling the areas thereafter including all debris etc., all as per instructions of Engineer-in-charge. Rate includes hire, fuel, operation charges, to and fro charges for machinery, all labour and all other incidentals etc., complete.	HR	1100.00

Item No.	Description	Unit	Rate (Rs.P)
II - CONCRETE WORKS			
0201	Providing and laying in position plain cement concrete of specified grade including consolidation, curing etc. complete, all as per standard specifications. All works upto plinth level. Rate excludes cost of centring and shuttering.		
A	1:1:2 with graded stone aggregate 20 mm nominal size. CEMENT CONSUMPTION - 610.00 K.G PER CUM	CUM	2019.90
B	1:1.5:3 with graded stone aggregate 20 mm nominal size. CEMENT CONSUMPTION - 400.00 K.G/CUM	CUM	1972.65
C	1:2:4 with graded stone aggregate 20 mm nominal size. CEMENT CONSUMPTION - 320.00 K.G/CUM	CUM	2043.75
D	1:2:4 with graded stone aggregate 40 mm nominal size. CEMENT CONSUMPTION - 320.00 K.G/CUM	CUM	1866.15
E	1:3:6 with graded stone aggregate 40 mm nominal size. CEMENT CONSUMPTION - 220.00 K.G/CUM	CUM	1913.70
F	1:4:8 with graded stone aggregate 40 mm nominal size. CEMENT CONSUMPTION - 170.00 K.G/CUM	CUM	1908.50
G	1:5:10 with graded stone aggregate 40 mm nominal size. CEMENT CONSUMPTION - 130.00 K.G/CUM	CUM	1904.35
H	1:4:8 with graded stone aggregate 20 mm nominal size. CEMENT CONSUMPTION - 170.00 K.G/CUM	CUM	2117.30
0202	Providing and laying in position specified grade of reinforced cement concrete including vibration charges, curing etc. complete but excluding cost of centring, shuttering, finishing and reinforcement.		
A	1:1:2 with graded stone aggregate 20 mm nominal size - All works upto plinth level. CEMENT CONSUMPTION - 610.00 K.G/CUM	CUM	2211.60
B	1:1.5:3 with graded stone aggregate 20 mm nominal size - All works upto plinth level. CEMENT CONSUMPTION - 400.00 K.G/CUM	CUM	2164.35
C	1:2:4 with graded stone aggregate 20 mm nominal size - All works upto plinth level. CEMENT CONSUMPTION - 320.00 K.G/CUM	CUM	2235.45
D	1:1:2 with graded stone aggregate 20 mm nominal size - Above plinth to floor five level. CEMENT CONSUMPTION - 610.00 K.G/CUM	CUM	2822.35
E	1:1.5:3 with graded stone aggregate 20 mm nominal size - Above plinth to floor five level. CEMENT CONSUMPTION - 400.00 K.G/CUM	CUM	2775.10
F	1:2:4 with graded stone aggregate 20 mm nominal size - Above plinth to floor five level.	CUM	2846.20

Item No.	Description	Unit	Rate (Rs.P)
CEMENT CONSUMPTION - 320.00 K.G/CUM			
0203	Straightening, cutting, bending, placing in position of MS/CTD bars and binding with MS binding wires of 18/20 gauge etc. for reinforcement of RCC works. Rate includes cover blocks, cost of binding wire , conveyance of MS/CTD bars from BHEL stores to site of work, labour etc. complete. MS/CTD bars will be supplied by BHEL at Stores at free of cost.	MT	7439.40
0204	Centring and shuttering including strutting, propping, assembling etc. and removal of form work. Upto a maximum height of 4.50 metre of each floor and also upto floor five level.		
A	Foundations, footings, bases of columns, equipment foundations, precast slabs, kerbs etc. for mass concrete.	SQM	167.30
B	Walls (any thickness) including attached pilasters, plinth, stairs, chimney, shafts and string courses etc.	SQM	291.65
C	Suspended floors, roofs, landings, balconies, access platform and sunshades.	SQM	323.65
D	Lintels, beams, plinth beams, girders, bressumers and cantilevers	SQM	253.50
E	Columns, pillars, piers, abutments, posts and struts.	SQM	371.70
F	Arches, domes, vaults upto 6 m span	SQM	783.80
G	Well steining	SQM	465.50
H (i)	Extra for shuttering : Foundations, footings, bases of columns, equipment foundations, precast slabs, kerbs etc. for mass concrete in circular work.	SQM	33.45
H (ii)	Extra for shuttering : Lintels, beams, plinth beams, girders, bressumers and cantilevers in circular work.	SQM	50.70
H (iii)	Extra for shuttering : Columns, pillars, piers, abutments, posts and struts in circular work.	SQM	74.35
I	Pockets or holes in foundations for holding down bolts.	SQM	679.25
0205	Extra for additional height in centring, shuttering wherever required with adequate bracing, propping etc. including cost of de-shuttering and de-centring at all levels, over a height of 4.5 metre for every additional height of 1 metre or part there of. For suspended floors, roofs, landing, beams & balconies (Plan area to be measured)	SQM	165.25

Item No.	Description	Unit	Rate (Rs.P)
0206	Providing and laying in position machine batched, machine mixed and machine vibrated design mix of reinforced cement concrete of specified grade for structural elements using 10 to 20 mm hard broken granite stone jelly, excluding cost of centring, shuttering, finishing and reinforcement but including admixtures in recommended proportions (as per IS:9103) to accelerate, retard setting of concrete, improve workability without impairing strength and durability, all as per directions of Engineer-in-charge. M-20 Grade reinforced cement concrete. All work in foundation, basement and upto Floor V level.	CUM	2728.60
	CEMENT CONSUMPTION - 383.00 K.G PER CUM		
0207	Providing and laying in position machine batched, machine mixed and machine vibrated design mix of reinforced cement concrete of specified grade for structural elements using 10 to 20 mm hard broken granite stone jelly, excluding cost of centring, shuttering, finishing and reinforcement but including admixtures in recommended proportions (as per IS:9103) to accelerate, retard setting of concrete, improve workability without impairing strength and durability, all as per directions of Engineer-in-charge.		
A	M-25 Grade reinforced cement concrete. All work in foundation, basement and upto Floor V level.	CUM	2737.05
	CEMENT CONSUMPTION - 410.00 K.G PER CUM		
B	M-30 Grade reinforced cement concrete. All work in foundation, basement and upto Floor V level.	CUM	2740.15
	CEMENT CONSUMPTION - 420.00 K.G PER CUM		
C	M-35 Grade reinforced cement concrete. All work in foundation, basement and upto Floor V level.	CUM	2742.70
	CEMENT CONSUMPTION - 428.00 K.G PER CUM		
0208	Extra for laying plain / reinforced concrete in or under foul conditions.	CUM	125.20
0209	Providing vertical drops, fins, facias etc., for the following thickness with 1:2:4 cement concrete using 6 mm granite stone chips for inner core applied on chickenmesh and neatly plastered with cement mortar 1:4, 12mm thick on both faces, finishing, curing etc., complete. Rate includes cost of all materials and labour but excluding fabrication charges for reinforcement.		
A	75mm thick	SQM	842.60
	CEMENT CONSUMPTION - 24.76 K.G PER SQM		
B	60 mm thick	SQM	830.55
	CEMENT CONSUMPTION - 20.68 K.G PER SQM		

Item No.	Description	Unit	Rate (Rs.P)
0210	Providing, hoisting and fixing upto floor five level precast reinforced cement concrete elements like slabs etc. of 25 to 150 mm thick in required sizes with mix 1:2:4 using 10 to 20 mm size hard broken granite stone jelly for cupboards, shelves etc. including setting in cement mortar 1:3, cost of centring, shuttering and finishing with neat cement punning on exposed surfaces but excluding the cost of reinforcement and fabrication charges.	CUM	6332.65
	CEMENT CONSUMPTION - 320.00 K.G PER CUM		
0211	Providing, hoisting and fixing upto floor V level plain cement concrete elements like slabs etc. of 25 to 150 mm thick of required sizes in mix 1:2:4 using 10 to 20 mm size hard broken granite stone jelly. Rate includes centring, shuttering & finishing with neat cement punning on exposed surfaces but excluding pointing.	CUM	5228.55
	CEMENT CONSUMPTION - 320.00 K.G PER CUM		
0212	Carrying from departmental stores / stack yard and fixing in position of 25 to 150 mm thick Plain / R C C precast elements like slabs etc. to the correct line, level, plumb and alignment, all as per standard specifications. Rate excludes cost of precast slabs and pointing.	CUM	506.60
0213	Providing precast cement concrete Jali 1:2:4 using graded stone aggregate 6 mm nominal size with suitable reinforcement including centring and shuttering, roughening, cleaning, fixing and finishing in cement mortar 1:3 etc.complete. Rate excludes reinforcement steel & fabrication charges.		
A	50 mm thick CEMENT CONSUMPTION - 12.80 K.G PER SQM	SQM	538.75
B	40 mm thick CEMENT CONSUMPTION - 10.24 K.G PER SQM	SQM	461.70
0214	Providing and fixing RCC precast perforated lawn drain cover slabs of following thickness in mix 1:2:4 using graded stone aggregate 10 mm nominal size including moulding, shuttering, finishing, carrying and fixing in position etc., complete. Rate excludes reinforcement steel & fabrication charges.		
A	75 mm thick CEMENT CONSUMPTION - 19.84 K.G PER SQM	SQM	264.95
B	50 mm thick CEMENT CONSUMPTION - 12.80 K.G PER SQM	SQM	161.60

Item No.	Description	Unit	Rate (Rs.P)
0215	Precasting, carrying and fixing in position of RCC louvers including 60 mm thick side posts, 60 mm thick intermittent lintel and 100 mm thick top lintel, 40 mm thick louver slabs lintels etc. (all precast) in cement concrete 1:2:4 using graded stone aggregate 10 mm nominal size with specified reinforcement, all as per standard drawing and instructions of Engineer-in-charge. Rate includes supply and fixing of holdfasts, moulding, scaffolding for fixing at specified levels, finishing and also filling the gap between precast lintels with insitu cement concrete of mix 1:2:4 using 10 mm and down graded hard broken granite stone jelly and filling the gap recesses of side walls with C.M 1:5, cutting and forming chases in brick masonry, finishing jambs wherever necessary and making good all damages to suit the existing work but excluding cost of fabrication charges for reinforcement steel.	SQM	772.80
CEMENT CONSUMPTION - 34.73 K.G PER SQM			
0216	Precasting and fixing in position of RCC cable trench cover slabs of following thickness in mix 1:2:4 using graded stone aggregate 12 mm nominal size with top 15 mm thick finished with hardening compound of proportion one part of ironite or equivalent, four parts of cement and eight parts of 6 mm gauge hard granite stone chips (the proportion being by weight) including welding reinforcement rods to the frame work, all as per drawing, specifications and instructions of Engineer-in-charge but excluding cost of M.S frame work which will be paid separately. Reinforcement rods and M.S frames will be supplied by BHEL at stores at free of cost.		
A	69mm thick slab CEMENT CONSUMPTION - 26.03 K.G PER SQM	SQM	543.65
B	150mm thick slab CEMENT CONSUMPTION - 52.00 K.G PER SQM	SQM	736.75
0217	Encasing rolled steel sections in beams and columns in cement concrete 1:2:4 using graded stone aggregate 12.50 mm nominal size including centering, shuttering etc. complete but excluding cost of reinforcement & fabrication charges.	CUM	4078.50
CEMENT CONSUMPTION - 320.00 K.G PER CUM			
0218	Providing balustrade for an overall thickness of 100 mm with cement concrete 1:2:4 using 12 to 20 mm size hard broken granite stone jelly for 75 mm thick inner core applied on chickenmesh and neatly plastered with cement mortar 1:4 on both faces and hand rail plastered in CM 1:4 with an admixture of red oxide including finishing, polishing curing etc., complete. Rate includes cost of all materials and labour but excluding cost of reinforcement and fabrication charges.	SQM	994.70
CEMENT CONSUMPTION - 32.92 K.G PER SQM			
0219	Extra for providing and fixing expanded metal mesh of size 20 x 60 mm and strands 3.25 mm wide 1.6 mm thick weighing 3.64 kg. per sqm for encasing of rolled steel sections in beams, columns and grillage excluding cost of hangers.	SQM	355.85

Item No.	Description	Unit	Rate (Rs.P)
0220	Providing and fixing in position of copper plate as per design for expansion joints.	K.G	306.05
0221	Providing and filling in position of blown bitumen in expansion joints.	CUM	50000.00
0222	Providing and filling in position of bitumen mix filler of proportion 80 Kg of hot bitumen, 1 Kg of cement and 0.25 cubicmetre of coarse sand for expansion joints.	SQM	15500.00
0223	Providing and fixing in position of 12 mm thick bitumen impregnated fibre board conforming to IS:1838 including cost of primer, sealing compound in expansion joints.	SQM	410.00
0224	Extra for providing and mixing water proofing material 'Impermo' or equivalent in cement concrete work at 1 Kg per 50 Kg of cement.	K.G	42.00
0225	Labour charges for attending to spalling of concrete in ceiling of buildings. Scope of step by step activities are given:- i) Removing the loose concrete / plaster by knocking with a 2 lbs hammer, scrapping with steel wire brush and exposing the sound concrete. ii) Removing the rust in reinforcement by scraping with steel brush. iii) Washing the concrete surface and reinforcement. (By jetting water) iv) Applying passivator coat (2 K.G cement & 1 Lit. Roff bond repair) on rusted reinforcement and bond coat using CM 1:3 & Roff bond repair (5 K.G cement & 1 Lit. Roff bond repair) in layers of 6 mm thick to match with the existing surface. Roff bond repair mix shall be prepared in the proportion as directed by Engineer-in-charge. OR Applying rust primer on the steel and maricrete mix to the surface to be attended to by adding water in proportion as directed by Engineer-in-charge in layers of 6 mm thick to match with the existing surface. v) Finishing the surface with clean trowel. Note:- I) Cement & the said chemicals will be supplied by BHEL at Stores at free of cost. ii) Rate includes scaffolding, tools, labour, incidentals etc. complete.	SQM	115.50
0226	Providing and placing in position PVC water stops serrated with central bulb, 225 mm wide & 8-11 mm thick for construction / expansion joints between two RCC members and fixed to the reinforcement with binding wire before pouring concrete etc. complete.	RM	462.05

Item No.	Description	Unit	Rate (Rs.P)
III - MASONRY WORKS			
0301	Random rubble masonry in foundation and basement in the mix given below including simultaneous flush pointing, all as per standard specifications.		
A	Cement mortar 1:5 CEMENT CONSUMPTION 102.30 K.G/CUM	CUM	1775.55
B	In cement mortar 1:6 CEMENT CONSUMPTION 82.50 K.G/CUM	CUM	1773.45
0302	Coursed rubble masonry (second sort) with hard stone in foundation and plinth with Cement mortar 1:6. CEMENT CONSUMPTION 75.00 K.G/CUM	CUM	2070.35
0303	Extra for random rubble masonry with hard stone curved on plan for a mean radius not exceeding 6 metre.	CUM	301.80
0304	Extra for random rubble and coursed rubble masonry with hard stone in superstructure above plinth level and upto floor five level.	CUM	645.50
0305	Extra for laying stone work in or under foul position.	CUM	125.20
0306	Labour charges for providing random rubble masonry in foundation & basement in the mixes specified including simultaneous flush pointing, all as per standard specifications. Rough stones & bond stones will be supplied by BHEL at free of cost, at site of work.	CUM	544.80
0307	Providing rough stone dry packing for aprons and revetments including filling interstices with spalls, wedging, consolidating and preparing the surface, all as per standard specifications.	CUM	1287.00
0308	Labour charges for providing rough stone dry packing for aprons and revetments including filling interstices with spalls, wedging, consolidating and preparing the surface, all as per standard specifications. Rough stones will be supplied by BHEL at site at free of cost.	CUM	884.40
0309	Providing hollow block masonry in cement mortar 1:5 using hollow block of sizes 400 x 200 x 200 mm / 400 x 150 x 200 mm / 400 x 100 x 200 mm or thereabouts of approved good quality including simultaneous flush pointing, all as per standard specification. Rate includes cost of hollow blocks, conveying, leading, loading, unloading, labour, incidentals etc., complete. Upto 4.50 m height from plinth level. CEMENT CONSUMPTION 23.77 K.G/CUM	CUM	3111.15
0310	Brick work with F.P.S bricks (second class ground moulded chamber bricks) of class designation 50/75 in foundation and plinth in:		
A	Cement mortar 1:3 CEMENT CONSUMPTION 127.50 K.G/CUM	CUM	3725.30
B	Cement mortar 1:4 CEMENT CONSUMPTION 95.00 K.G/CUM	CUM	3721.90
C	Cement mortar 1:5	CUM	3720.10

Item No.	Description	Unit	Rate (Rs.P)
	CEMENT CONSUMPTION 77.50 K.G/CUM		
D	Cement mortar 1:6	CUM	3718.50
	CEMENT CONSUMPTION 62.50 K.G/CUM		
0311	Brick work with modular bricks (second class table moulded chamber bricks) of class designation 50/75 in foundation and plinth in:		
A	Cement mortar 1:3	CUM	3899.00
	CEMENT CONSUMPTION 112.20 K.G/CUM		
B	Cement mortar 1:4	CUM	3896.05
	CEMENT CONSUMPTION 83.60 K.G/CUM		
C	Cement mortar 1:5	CUM	3894.45
	CEMENT CONSUMPTION 68.20 K.G/CUM		
D	Cement mortar 1:6	CUM	3893.05
	CEMENT CONSUMPTION 55.00 K.G/CUM		
0312	Extra for Brick work in superstructure above plinth upto floor three level in all shapes and sizes.	CUM	271.25
0313	Extra for brick work with bricks curved on plan upto a mean radius not exceeding 6 metre.	CUM	473.90
0314	Extra charges for providing half brick masonry, brick on edge walls, fins, balustrade etc. over and above the brick work rates of 0310 & 0311.	CUM	297.60
0315	Honey-comb brick work 10 / 11.40 cm thick with FPS bricks of class designation 50 in cement mortar 1:4.	SQM	314.15
	CEMENT CONSUMPTION 6.56 K.G/CUM		
0316	Extra for laying brick work in or under foul position.	CUM	125.20
0317	Providing and filling with 20 mm brick jelly including filling the voids (max.of 10%) with river sand and compacted well with wooden hammer etc. complete.	CUM	687.50
0318	Rectifying the wall cracks by chipping off the existing plastered surfaces to the required width, depth and applying cement slurry in the cracks to the required depth, making good all damages and finishing to match with the existing one by plastering with C.M 1:5, 12/15mm thick and a coat of white wash / snowcem / distemper etc. as the case may be.	SQM	93.30
0319	Rectifying the wall cracks by chipping off the existing plastered surfaces to the required width, depth and applying cement slurry in the cracks to the required depth, making good all damages, providing chickenmesh and finishing to match with the existing one by plastering with C.M 1:5, 12/15mm thick and a coat of white wash / snowcem / distemper etc. as the case may be.	SQM	133.70

Item No.	Description	Unit	Rate (Rs.P)
0320	Brick work with mechanized autoclaved fly ash lime bricks made up of fly ash, lime, gypsum and coarse sand / stone dust to size 230 mm x 110 mm x 70 mm or thereabouts confirming to IS 12894 of class designation 50 (min) in foundation, plinth and superstructure above plinth up to floor V level as per standard specifications and instructions of Engineer in charge In cement mortar 1:5 CEMENT CONSUMPTION 77.50 K.G/CUM	CUM	4320.70
0321	Brick work with non modular fly ash lime bricks (FALG Bricks) conforming to IS:12894, class designation 10 average compressive strength in foundation, plinth and superstructure above plinth up to floor V level as per standard specifications and instructions of Engineer in charge In cement mortar 1:5 CEMENT CONSUMPTION 95.00 K.G/CUM	CUM	4160.00

Item No.	Description	Unit	Rate (Rs.P)
IV - WOOD WORKS			
0401	Providing best wooden frames for doors, windows, ventilators and other frames, wrought framed and fixed in position. All as per standard specifications and drawings. Rate includes cost of wood, holdfasts, other materials, labour etc. complete.		
A	In Teak wood	CUM	109029.20
B	In Country wood	CUM	46085.35
0402	Providing best wooden frames for false ceiling, partitions etc. sawn and put up in position. All as per standard specifications and drawings. Rate includes cost of wood, M.S suspenders, screws, nails, other materials involved, labour, etc. complete.		
A	In Teak wood	CUM	113394.25
B	In Country wood	CUM	38851.80
0403	Labour charges for wrought and put up in position for all kinds of frames including fixing of holdfasts etc. complete. Rate excludes cost of wood and holdfasts.	CUM	9765.45
0404	Manufacture, supply and fixing best wooden door with frames and shutters comprising of fully panelled shutter of 35 mm thick and frame of size 95 x 70 mm including cost of holdfasts but excluding cost of furniture fittings & fitting charges.		
A	In Teak wood	SQM	4807.75
B	In Country wood	SQM	2257.90
0405	Manufacture, supply and fixing in position of 35 mm thick fully panelled best wooden door shutters. All as per standard specifications & drawings. (Excluding door frame) Rate excludes furniture fittings.		
A	In Teak wood (single leaved shutter)	SQM	3375.90
B	In Teak wood (double leaved shutter)	SQM	3280.95
C	In Country wood (single leaved shutter)	SQM	1583.15
D	In Country wood (double leaved shutter)	SQM	1552.20
0406	Supply and fixing in position of 38/40mm thick best quality flush shutters solid core type of approved quality with formaldehyde bonded teak ply (both faces) and with teak wood internal lippings etc., complete all as per drawings and standard specifications but excluding cost of frame and furniture fittings. (Area of shutter only to be measured)		
A	Single leaved shutter	SQM	3084.80
B	Double leaved shutter	SQM	3244.10

Item No.	Description	Unit	Rate (Rs.P)
0407	Manufacture, supply and fixing in position of G.I sheet single leaved door with best country wood frame alround using 75 x 35 mm scantlings, including horizontal member of 75 x 35 mm at 600 mm c/c with 1.20 to 1.25 mm thick GI plain sheet on one side including sizing, fixing, cost of oxidised iron hinges, aluminium tower bolts, aluminium handles etc., all as per standard specifications & drawings.	SQM	1294.80
0408	Manufacture, supply and fixing double leaved wooden window with best wood and type of shutters given below with wooden frames of size 95 x 70 mm including sizing and fixing of 12/16 mm dia M.S rods and holdfasts but excluding cost of M.S rods, furniture fittings etc. complete.		
A	In Teak wood. 35 mm thick shutter with 4 mm plain glass panes.	SQM	6139.95
B	In Teak wood. 35 mm thick shutter with 4 mm pin headed glass panes.	SQM	6102.45
C	In Teak wood. 35 mm thick shutter with 3 mm pin headed glass panes.	SQM	6113.55
D	In Teak wood. 35 mm thick shutter with 16 mm teak panels.	SQM	6670.65
E	In Teak wood. 35 mm thick shutter with partly panelled and partly glazed. (16 mm panels and 4 mm plain glass panes)	SQM	6437.80
F	In Country wood. 35 mm thick shutter with 4 mm plain glass panes.	SQM	3034.10
G	In Country wood. 35 mm thick shutter with 4 mm pin headed glass panes.	SQM	2996.60
H	In Country wood. 35 mm thick shutter with 3 mm pin headed glass panes.	SQM	3007.70
I	In Country wood. 35 mm thick shutter with 16 mm country wood panels.	SQM	3166.70
J	In Country wood. 35 mm thick shutter with partly panelled and partly glazed. (16 mm country wood panels and 4 mm plain glass panes)	SQM	3104.45
0409	Manufacture, supply and fixing in position of double leaved best wooden window shutters using 70 x 35 mm styles and rails, all as given below. All as per standard specifications & drawings. (<u>Excluding window frame</u>) Rate excludes window frame and furniture fittings.		
A	In Teak wood. 35 mm thick shutter with 4 mm plain glass panes.	SQM	3063.75
B	In Teak wood. 35 mm thick shutter with 4 mm pin headed glass panes.	SQM	3012.70
C	In Teak wood. 35 mm thick shutter with 3 mm pin headed glass panes.	SQM	3027.80
D	In Teak wood. 35 mm thick shutter with 16 mm teak panels.	SQM	3786.50
E	In Teak wood. 35 mm thick shutter with partly panelled and partly glazed. (16 mm teak wood panels and 4 mm plain glass panes)	SQM	3469.40
F	In Country wood. 35 mm thick shutter with 4 mm plain glass panes.	SQM	1824.45
G	In Country wood. 35 mm thick shutter with 4 mm pin headed glass panes.	SQM	1773.40

Item No.	Description	Unit	Rate (Rs.P)
H	In Country wood. 35 mm thick shutter with 3 mm pin headed glass panes.	SQM	1788.50
I	In Country wood. 35 mm thick shutter with 16 mm country wood panels.	SQM	2005.00
J	In Country wood. 35 mm thick shutter with partly panelled and partly glazed. (16 mm country wood panels and 4 mm plain glass panes)	SQM	1920.25
0410	Manufacture, supply and fixing fully glazed swing type ventilator using best wooden frame of size 95 x 70 mm, wooden shutter of thickness 35 mm with glass panes including sizing and fixing 16mm dia. M.S. rods but excluding cost of M.S. rods, holdfasts and furniture fittings. <u>(Excluding bottom frame for fixing over doors and windows.)</u>		
A	In Teak wood with 4 mm plain glass panes for shutter.	SQM	4900.65
B	In Teak wood with 3 mm pin headed glass panes for shutter.	SQM	4868.25
C	In Country wood with 4 mm plain glass panes for shutter.	SQM	2419.10
D	In Country wood with 3 mm pin headed glass panes for shutter.	SQM	2386.70
0411	Manufacture, supply and fixing fully glazed swing type ventilator using best wooden frame of size 95 x 70 mm, wooden shutter of thickness 35 mm with glass panes including sizing and fixing 16mm dia. M.S. rods but excluding cost of M.S. rods, holdfasts and furniture fittings.		
A	In Teak wood with 4 mm plain glass panes for shutter.	SQM	5584.50
B	In Teak wood with 3 mm pin headed glass panes for shutter.	SQM	5556.00
C	In Country wood with 4 mm plain glass panes for shutter.	SQM	2647.55
D	In Country wood with 3 mm pin headed glass panes for shutter.	SQM	2619.05
0412	Manufacture, supply and fixing in position of fully glazed fixed type louvered ventilator using best wooden frame of size 75 x 50 mm and using 4 mm thick plain glass panes for louvers, all as per drawings and standard specifications. Rate includes supply and fixing of MS holdfasts.		
A	In Teak wood	SQM	4280.55
B	In Country wood	SQM	2064.20
0413	Manufacture, supply and fixing in position of fully glazed shutter in best wooden frame of 35 mm thick for ventilator. Rate excludes ventilator frame and furniture fittings.		
A	In Teak wood with 4 mm plain glass panes for shutter.	SQM	2290.15
B	In Teak wood with 3 mm pin headed glass panes for shutter.	SQM	2246.05
C	In Country wood with 4 mm plain glass panes for shutter.	SQM	1442.40
D	In Country wood with 3 mm pin headed glass panes for shutter.	SQM	1398.35

Item No.	Description	Unit	Rate (Rs.P)
0414	Labour charges for manufacturing the following wood work items either in teak or country wood and fixing in proper position at site of work. All as per standard specifications and drawings. Rate excludes cost of wood, furniture fittings and its fitting charges.		
A	Fully panelled door shutter / window shutter (excluding door / window frame)	SQM	580.00
B	Partly glazed and partly panelled door shutter / window shutter/ fully glazed window shutter (excluding door / window frame)	SQM	535.70
C	Fully glazed shutter/shutter with frame for ventilator	SQM	493.35
0415	Labour charges for fixing doors, windows and ventilators including frames and shutters in position etc. complete.(wood or steel)	SQM	118.90
0416	Labour charges for fixing the following in proper position.		
A	Shutter only for doors, windows, ventilators etc.	SQM	23.80
B	Frame only for doors, windows, ventilators etc.	EACH	171.25
0417	Cutting to size and fixing M.S rods/bars in window and ventilator frames and other petty works. (labour only)	K.G	12.30
0418	Supply and fixing M.S grills for windows, ventilators and also wherever necessary including a priming coat. All according to our design and specification.	K.G	13.20
0419	Supply of MS round or square bars at site of work for windows, ventilators, other petty works etc.	K.G	49.50
0420	Manufacture, supply and fixing in position of cupboard shutters with best teakwood frame of size 100 x 35 mm and 25 mm thick best quality prelaminate particle board (exterior grade) as flush shutters etc., complete, all as per standard specifications and drawings. Rate includes holdfasts but excludes furniture fittings.	SQM	2214.00
0421	Manufacture, supply and fixing in position of fly proof shutters with best teakwood frame of size 75 x 25 mm and 20 mm thick shutters using 50 x 20 mm teakwood styles and rails including supply and fixing of best quality galvanised wire mesh of average width of aperture 1.4 mm and nominal dia of wire 0.63 mm including cost of holdfasts, oxidised iron butt hinges and other fittings of anodised aluminium including providing locking arrangements etc., complete, all as per standard specifications.	SQM	2248.65
0422	Providing and fixing best teak wood of 12 mm thick and 150 mm wide for pelmet of doors and windows with necessary provision for fixing curtain rod. Rate excludes curtain rod. (Only horizontal length between supports will be measured and paid)	RM	446.10

Item No.	Description	Unit	Rate (Rs.P)
0423	Providing and fixing prelaminated particle board (exterior grade) of approved brand and quality 12 mm thick and 150 mm wide for pelmet of doors and windows with necessary provision for fixing curtain rod. Rate excludes curtain rod.(Only horizontal distance between supports will be measured and paid)	RM	302.35
0424	Providing and fixing curtain rods of the following. Rate includes cost of rods, cutting to required lengths, fixing in position etc. complete.		
A	MS pipe nickel plated 20 mm dia (HD) with nickel plated brackets.	RM	99.20
B	Anodised aluminium tube of 20 mm dia with suitable brackets.	RM	63.25
0425	Providing and fixing best teakwood beading of size 50 x 25 mm on walls including supply and fixing of hooks at required intervals etc., complete.	RM	84.75
0426	Supply and fixing mild steel balustrade of overall height 90 cm fabricated with 40 x 5 mm M.S. flats and 15 mm M.S. square bars painted with one coat of red oxide primer, including supply and fixing of best teak wood hand rail of size 75 x 75 mm at top finished smooth. All as per standard specifications & drawings.	RM	1577.15
0427	Supply & fixing the following furniture fittings of approved brand & quality (ISI marked) in the appropriate position of doors, windows, ventilators, cupboards etc. with appropriate screws, nails etc., all as per standard specifications & instructions of Engineer in charge.		
A	Hydraulic door closer - universal type (Medium duty)	EACH	1425.45
B	Hydraulic door closer - universal type (Heavy duty)	EACH	1507.00
C	Brass Mortice lock 100 mm, 6 levers and a pair of brass lever handles	EACH	492.40
D	D type Anodised Aluminium handle - 75 mm	EACH	20.90
E	D type Anodised Aluminium handle - 100 mm	EACH	31.90
F	D type Anodised Aluminium handle - 125 mm	EACH	35.75
G	250 x 12 mm Anodised Aluminium aldrops	EACH	140.85
H	250 x 16 mm Anodised Aluminium aldrops	EACH	170.50
I	300 x 16 mm Anodised Aluminium aldrops	EACH	206.80
J	50 x 11/12 mm Anodized Aluminium tower bolt	EACH	32.90
K	75 x 11/12 mm Anodized Aluminium tower bolt	EACH	38.50
L	100 x 11/12 mm Anodized Aluminium tower bolt	EACH	47.30
M	150 x 11/12 mm Anodized Aluminium tower bolt	EACH	64.90

Item No.	Description	Unit	Rate (Rs.P)
N	200 x 11/12 mm Anodized Aluminium tower bolt	EACH	99.00
O	250 x 11/12 mm Anodized Aluminium tower bolt	EACH	143.00
P	300 x 11/12 mm Anodized Aluminium tower bolt	EACH	176.00
Q	50 mm oxidised iron butt hinges (Heavy duty)	EACH	10.45
R	125 mm oxidised iron butt hinges (Heavy duty)	EACH	22.55
S	150 mm oxidised iron butt hinges (Heavy duty)	EACH	43.45
T	125 mm oxidised iron parliamentary hinges (Heavy duty)	EACH	42.35
U	150 x100 mm oxidised iron parliamentary hinges (Heavy duty)	EACH	45.10
V	50 mm oxidised iron tower bolt (Heavy duty)	EACH	20.90
W	100 mm oxidised iron tower bolt (Heavy duty)	EACH	30.80
X	150 mm oxidised iron tower bolt (Heavy duty)	EACH	42.90
Y	250 mm oxidised iron tower bolt (Heavy duty)	EACH	60.50
Z	300 mm oxidised iron tower bolt (Heavy duty)	EACH	77.00
A1	250 x 16 mm oxidised iron Aldrop (Heavy duty)	EACH	126.50
B1	300 x 16 mm oxidised iron Aldrop (Heavy duty)	EACH	129.80
C1	200 mm brass iron hook and eye	EACH	72.60
D1	250 mm brass iron hook and eye	EACH	78.65
E1	Anodised aluminium Hanging type door stopper	EACH	31.90
F1	PTMT handle 125x34x24 mm	EACH	38.50
G1	PTMT handle 150x34x24 mm	EACH	42.90
H1	PTMT butt hinges 75x60x10 mm	EACH	57.20
I1	PTMT butt hinges 100x75x10 mm	EACH	72.60
J1	PTMT Tower bolt 152x42x18 mm	EACH	82.50
K1	PTMT Tower bolt 202x42x18 mm	EACH	99.00

Item No.	Description	Unit	Rate (Rs.P)
0428	Providing and fixing cupboard shutter 25 mm thick, melamine faced prelaminated with flat pressed three layer particle board conforming to IS:12823 exterior grade (Grade I Type II) having one side decorative lamination of approved shade and other side balancing lamination including II class teak wood lipping of 25 mm wide & 12 mm thick with necessary screws, nickel plated bright finished M.S piano hinges etc. complete.	SQM	1471.35
0429	Providing and fixing cupboard shutter 25 mm thick particle board with teak veneering on one side & commercial veneering on the other side conforming to IS:3087 exterior grade (Grade I) of approved make including II class teak wood lipping of 25 mm wide & 12 mm thick with necessary screws, nickel plated bright finished M.S piano hinges, etc. complete.	SQM	1350.35
0430	Providing and fixing factory made flush door shutter 30 mm thick made of prelaminated flat pressed three layer particle board conforming to IS:12823 exterior grade (Grade I Type II) having one side decorative lamination of approved shade and other side balancing lamination including II class teak wood lipping of 30 mm wide & 12mm thick with necessary screws, black enamelled M.S butt hinges, etc. complete.	SQM	1477.20
0431	Providing and fixing factory made uPVC door frame made of uPVC extruded sections having an overall dimension as below (tolerance ± 1 mm), with wall thickness 2.0 mm (± 0.2 mm), corners of the door frame to be Jointed with galvanized brackets and stainless steel screws, joints mitred and Plastic welded. The hinge side vertical of the frames reinforced by galvanized M.S. tube of size 19 X 19 mm and 1mm (± 0.1 mm) wall thickness and 3 nos. stainless steel hinges fixed to the frame complete as per manufacturer's specification and direction of Engineerin- charge		
	a Extruded section profile size 48x40 mm	RM	188.10
	b Extruded section profile size 42x50 mm.	RM	177.10
0432	Providing and fixing to existing door frames, 24 mm thick factory made PVC door shutters made of styles and rails of a uPVC hollow section of size 59x24 mm and wall thickness 2 mm (± 0.2 mm) with inbuilt edging on both sides. The styles and rails mitred and joint at the corners by means of M.S. galvanised/plastic brackets of size 75x220 mm having wall thickness 1.0 mm and stainless steel screws. The styles of the shutter reinforced by inserting galvanised M.S. tube of size 20x20 mm and 1 mm (± 0.1 mm) wall thickness. The lock rail made up of 'H' section, a uPVC hollow section of size 100x24 mm and 2 mm (± 0.2 mm) wall thickness, fixed to the shutter styles by means of plastic/galvanised M.S. 'U' cleats. The shutter frame filled with a uPVC multichambered single panel of size not less than 620 mm, having over all thickness of 20 mm and 1 mm (± 0.1 mm) wall thickness. The panels filled vertically and tie bar at two places by inserting horizontally 6 mm galvanised M.S. rod and fastened with nuts and washers, complete as per manufacturer's specification and direction of Engineer-in-charge. (For W.C. and bathroom door shutter).	SQM	2500.60

Item No.	Description	Unit	Rate (Rs.P)
0433	<p>Providing and fixing to existing door frames, 30 mm thick factory made Polyvinyl Chloride (PVC) door shutter made of styles and rails of uPVC hollow section of size 60x30 mm and wall thickness 2 mm (± 0.2 mm), with inbuilt decorative moulding edging on one side. The styles and rails mitred and joint at the corners by means of M.S. galvanised/plastic brackets of size 75x220 mm having wall thickness 1.0 mm and stainless steel screws. The styles of the shutter reinforced by inserting galvanised M.S. tube of size 25x20 mm and 1 mm (± 0.1 mm) wall thickness. The lock rail made up of 'H' section, a uPVC hollow section of size 100x30 mm and 2 mm (± 0.2 mm) wall thickness fixed to the shutter styles by means of plastic/ galvanised M.S. 'U' cleats. The shutter frame filled with a uPVC multi-chambered single panel of size not less than 620 mm, having over all thickness of 20 mm and 1 mm (± 0.1 mm) wall thickness . The panels filled vertically and tie bar at two places by inserting horizontally 6 mm galvanised M.S. rod and fastened with nuts and washers, complete as per manufacturer's specification and direction of Engineer -in-charge.</p>	SQM	2610.55
0434	<p>Providing and fixing to existing door frames, 25 mm thick PVC flush door shutters made out of a one piece Multi chamber extruded PVC section of the size of 762mm X 25 mm or less as per requirement with an average wall thickness of 1 mm (± 0.3 mm). PVC foam end cap of size 23x10 mm are provided on both vertical edges to ensure the overall thickness of 25 mm. An M.S. tube having dimensions 19 mm x 19 mm and 1.0 mm (± 0.1 mm) is inserted along the hinge side of the door. Core of the door shutter should be filled with High Density Polyurethane foam. The Top & Bottom edges of the shutter are covered with an end-cap of the size 25 mm X 11 mm. Door shutter shall be reinforced with special polymeric reinforcements as per manufacturer's specification and direction of Engineer-in-charge to take up necessary hardware and fixtures. Stickers indicating the locations of hardware will be pasted at appropriate places.</p>	SQM	2500.55
0435	<p>Providing and fixing factory made P.V.C. door frame of size 50x47 mm with a wall thickness of 5 mm, made out of extruded 5 mm rigid PVC foam sheet, mitred at corners and joined with 2 Nos. of 150 mm long brackets of 15x15 mm M.S. square tube, the vertical door frame profiles to be reinforced with 19x19 mm M.S. square tube of 19 gauge, EPDM rubber gasket weather seal to be provided through out the frame. The door frame to be fixed to the wall using M.S. screws of 65/100 mm size, complete as per manufacturer's specification and direction of Engineer-in-Charge.</p>	RM	409.25

Item No.	Description	Unit	Rate (Rs.P)
0436	Providing and fixing factory made 30 mm thick door shutter made of solid PVC foam profile. The styles & rails shall be of size 75 mm x 30 mm having wall thickness 5 mm. The styles, top & bottom rails shall have one side wall thickness of 15 mm integrally extruded on the hinge side of the profile for better screw holding power. The styles and rails shall be reinforced with M.S. tubes of size 33 mm x 17 mm x 1 mm, painted with primer, all four corners of reinforcement to be welded or sealed. Solid PVC extruded bidding (push fit type) will be set inside the styles and the rails with a cavity, to receive single piece extruded 5 mm PVC sheet as panel. The styles and rails will be mitred cut and joint with the help of PVC solvent cement & self driven self tapping screws. Single piece extruded solid PVC lock rail of size 100 mm x 30 mm with wall thickness 5 mm & 15 mm integrally extruded in the middle of the lock rail & fixed with styles with the help of PVC solvent cement & self driven self tapping screws of size 100 mm x 8 mm complete as per manufacturer's specifications and direction of Engineer-in-charge.		
	a Non decorative finish.	SQM	2482.30
	b Decorative finish (both side wood grained finish).	SQM	3078.50
0437	Removing the damaged door shutter from door frame in buildings, conveying the same to site of work, dismantling the damaged bottom rail and other required portions, supply and replacing with suitable bottom rail of best country wood of maximum size 200x35 mm & length 775 mm and <u>covered with supply & fixing of 28 gauge G.I sheet at the bottom on both sides of shutter</u> to a width & height of 775 mm & 900 mm respectively including cutting, sizing, finishing, conveying and refixing the finished door shutter in proper position in buildings, all as per instructions of Engineer in charge. Rate also includes cost of all accessories such as nails, screws, fevicol etc.	EACH	714.95
0438	Removing the existing partition with door carefully from its position without damaging any portion of the partition, handing over the reusable items to the departmental stores / stacking at site. All as per the instructions of Engineer-in-charge.		
	A Teakwood partition partly panelled and partly glazed	SQM	123.20
	B Teakwood / Aluminium partition panelled or glazed	SQM	148.10
0439	Conveying partition along with doors from departmental stores / stacks and fixing the same in position without damaging the frame work and glass. Rate includes cost of additional rubber gaskets, aluminium frame work and beading if required for fixing the glasses for panels rigidly in position, cost of all materials, labour, scaffolding, tools and plants and other incidentals etc. complete. All as per the instructions of Engineer-in-charge.		
	A Teakwood partly panelled and partly glazed.	SQM	651.45
	B Teakwood / Aluminium partition Panelled / Glazed	SQM	292.35

Item No.	Description	Unit	Rate (Rs.P)
V - STEEL WORKS			
0501	Collection from BHEL stores and transporting the raw structural steel sections to the contractor's site fabrication shop, fabrication of steel work including all materials going into the process of fabrication and forming an integral part of the steel work together with all shop welding including using low hydrogen electrode wherever necessary, all as per drawings and standard specifications. Rate includes delivery of fabricated steel work at erection site ready for erection, including preparation and supply of drawing office despatch list for BHEL's approval, all charges for packing (wherever called for) handling, conveying, stacking and all other incidental charges both for raw materials and fabricated steel works. Rate excludes raw structural steel sections which will be supplied by BHEL at stores at free of cost.	M.T	12371.75
0502	Collection from BHEL stores and transporting the raw structural steel sections to the contractor's site fabrication shop, fabrication of steel work including all materials going into the process of fabrication and forming an integral part of the steel work together with all shop welding including using low hydrogen electrode wherever necessary, all as per drawings and standard specifications. Rate includes delivery of fabricated steel work at erection site ready for erection, including preparation and supply of drawing office despatch list for BHEL's approval, all charges for packing (wherever called for) handling, conveying, stacking and all other incidental charges both for raw materials and fabricated steel works. Rate excludes raw structural steel sections and all consumables which will be supplied by BHEL at stores at free of cost.	M.T	9505.75
0503	Collection from BHEL stores and transporting ERW/seamless steel tubes with necessary plates to the contractor's site fabrication shop, fabrication of ERW/seamless steel tubes with necessary plates etc. instead of structural steel sections for columns, trusses, purlins, tie runners etc. (all tubular) including all materials going into the process of fabrication and forming an integral part of the steel work together with all shop welding including using low hydrogen electrode wherever necessary, all as per drawings and standard specifications. Rate includes delivery of fabricated steel work at erection site ready for erection, including preparation and supply of drawing office despatch list for BHEL's approval, all charges for packing (wherever called for) handling, conveying, stacking and all other incidental charges both for raw materials and fabricated steel works. Rate excludes ERW/seamless steel tubes, plates etc. which will be supplied by BHEL at stores at free of cost.	M.T	13608.90

Item No.	Description	Unit	Rate (Rs.P)
0504	Collection from BHEL stores and transporting ERW/seamless steel tubes with necessary plates to the contractor's site fabrication shop, fabrication of ERW/seamless steel tubes with necessary plates etc. instead of structural steel sections for columns, trusses, purlins, tie runners etc. (all tubular) including all materials going into the process of fabrication and forming an integral part of the steel work together with all shop welding including using low hydrogen electrode wherever necessary, all as per drawings and standard specifications. Rate includes delivery of fabricated steel work at erection site ready for erection, including preparation and supply of drawing office despatch list for BHEL's approval, all charges for packing (wherever called for) handling, conveying, stacking and all other incidental charges both for raw materials and fabricated steel works. Rate excludes ERW/seamless steel tubes, plates etc. and all consumables which will be supplied by BHEL at stores at free of cost.	M.T	10456.30
0505	Carrying from stacks at erection site to erection positions and erection of fabricated steel work including all handling, conveying, assembling, hoisting, erecting in position and site welding and or bolting, alignment of structures, all as per drawings and standard specifications. Rate includes bolts & nuts, hire for welding tools and plants, labour etc., but excluding cost of fabricated components. If required, power will be given free of cost by BHEL. Weight of fasteners will not be accounted for payment.	M.T	6667.90
0506	Carrying from stacks at erection site to erection positions and erection of fabricated steel work including all handling, conveying, assembling, hoisting, erecting in position and site welding and or bolting, alignment of structures, all as per drawings and standard specifications. Rate includes hire for welding tools and plants, labour etc., but excluding all consumables such as electrodes, bolts, nuts, washers etc. which will be supplied by BHEL at Stores at free of cost and cost of fabricated components. If required, power will be given free of cost by BHEL. Weight of fasteners will not be accounted for payment.	M.T	6364.10
0507	Fabrication and fixing in position of M.S frames for cable trench cover slabs in required sizes using M.S angles, plates, flats etc., which will be supplied by BHEL at Stores at free of cost, all as per drawings and instructions of Engineer-in-charge. Rate includes conveyance of raw materials from BHEL stores to contractors fabrication shop, fabrication charges including cutting, welding, preparing and supplying DODL's for BHEL's approval, supply of fabricated frames at site of work, fixing in proper position etc., complete.	M.T	7550.25

Item No.	Description	Unit	Rate (Rs.P)
0508	Fabrication and fixing in position of M.S frames for cable trench cover slabs in required sizes using M.S angles, plates, flats etc., which will be supplied by BHEL at Stores at free of cost, all as per drawings and instructions of Engineer-in-charge. Rate includes conveyance of raw materials from BHEL stores to contractors fabrication shop, fabrication charges including cutting, welding, preparing and supplying DODL's for BHEL's approval, supply of fabricated frames at site of work, fixing in proper position etc., complete but excludes all consumables such as electrodes which will be supplied by BHEL at Stores at free of cost.	M.T	6910.30
0509	Conveying from BHEL stores to site of work cutting to size and fixing in position of 75 x 75 x 6 mm or other size M.S angles in required lengths for forming the rebates in cable trench (for fixing the cable trench cover slabs) including welding in position of dowel bars to the angles and embedding the angle iron frame in the flooring concrete in proper line and level, all as per drawings and instructions of Engineer-in-charge. Rate includes loading, unloading, handling, welding and other incidental charges, preparing and supplying of DODL's for approval etc. complete, but excluding cost of M.S angles and dowel bars which will be supplied by BHEL at Stores at free of cost.	M.T	8041.55
0510	Same as 0509 but excluding all consumables which will be supplied by BHEL at Stores at free of cost. (Also excludes energy charges)	M.T	7397.25
0511	Fabrication and fixing in position of M.S inserts out of M.S plates, flats, rounds, angles etc., including necessary lugs made of rounds or flats, sizing and cutting to required lengths, threading, bolting and welding as required and placing the same in position in both plain and reinforced cement concrete members, including adjusting the shuttering if necessary, tying and holding to correct level and line. Rate includes cost of all materials, labour etc., complete but excluding raw steel sections which will be supplied by BHEL at Stores at free of cost.	K.G	28.2
0512	Fabrication and fixing in position of M.S inserts out of M.S plates, flats, rounds, angles etc., including necessary lugs made of rounds or flats, sizing and cutting to required lengths, threading, bolting and welding as required and placing the same in position in both plain and reinforced cement concrete members, including adjusting the shuttering if necessary, tying and holding to correct level and line. Rate includes cost of all materials, labour etc., complete but excluding raw steel sections and all consumables which will be supplied by BHEL at Stores at free of cost.	K.G	26.8

Item No.	Description	Unit	Rate (Rs.P)
0513	Fabrication of various sizes steel partitions (not exceeding 4.00 x 2.40 m) using M.S angles for outer frame work and flats for vertical and horizontal stiffeners etc. Bottom panels are to be welded with M.S sheets for a height of one metre (approx.) and top panels with BRC fabric (75 x 25 mm) All as per drawings and as directed by the Engineer-in-charge. Rate includes providing necessary holes for inter connections and also base plates for fixing on the floor, all labour, electrodes, conveyance of raw materials from stores to fabrication site, etc. complete, but excluding cost of steel sections and BRC fabrics which will be supplied by BHEL at Stores at free of cost.	SQM	247.95
0514	Fabrication of various sizes steel partitions (not exceeding 4.00 x 2.40 m) using M.S angles for outer frame work and flats for vertical and horizontal stiffeners etc. Bottom panels are to be welded with M.S sheets for a height of one metre (approx.) and top panels with BRC fabric (75 x 25 mm) All as per drawings and as directed by the Engineer-in-charge. Rate includes providing necessary holes for inter connections and also base plates for fixing on the floor, all labour, electrodes, conveyance of raw materials from stores to fabrication site, etc. complete, but excluding cost of steel sections, BRC fabrics and all consumables which will be supplied by BHEL at Stores at free of cost.	SQM	216.65
0515	Erection of fabricated steel partitions including handling, leading, assembling, erecting in position, site bolting, revetting, site welding etc., wherever required including cost of drilling holes in concrete floor and grouting bolts for fixing the base plates of steel partitions wherever necessary, all as per instructions of Engineer in charge. Rate includes all labour, incidentals etc., complete.	SQM	131.6
0516	Erection of fabricated steel partitions including handling, leading, assembling, erecting in position, site bolting, revetting, site welding etc., wherever required including cost of drilling holes in concrete floor and grouting bolts for fixing the base plates of steel partitions wherever necessary, all as per instructions of Engineer in charge. Rate includes all labour, incidentals etc., complete but excluding all consumables which will be supplied by BHEL at Stores at free of cost.	SQM	124.55
0517	Fabrication of S.S tubes / ERW tubes to the design specified for railing. Rate includes conveyance of raw materials and fabricated railings, fabrication charges, preparation of DODLs, incidentals etc., complete. Tubes and other steel materials required for the work will be supplied by BHEL at Stores at free of cost.	M.T	12371.75
0518	Carrying from stacks to site of work and fixing in position in line, level and alignment of fabricated railings at places as directed by the Engineer-in-charge. Excavation for pits and concrete bed will be paid separately under relevant items.	M.T	4857.50

Item No.	Description	Unit	Rate (Rs.P)
0519	Providing holding down bolts of required sizes with nuts, washers etc. and fixing in proper level, line, alignment etc., all as per drawings and instructions of Engineer-in-charge. Rate includes cost of steel materials, bolts, nuts, washers, fabrication and machining charges, fixing, all labour etc. complete.		
A	In M.S rounds including washer plates.	KG	65.80
B	Bolts including nuts & washers etc.complete in all sizes & lengths.	KG	85.15
0520	Conveying all types & sizes of holding down bolts, nuts, washers etc. from BHEL Stores to site of work and fixing in proper level, line, alignment etc., all as per drawings and instructions of Engineer-in-charge. Rate excludes cost of bolts, nuts, washers etc.	KG	23.55
0521	Providing and fixing in position of M.S rivets of required sizes at site of work.	KG	116.55
0522	Welding by gas plant or electric plant including transportation of plant to site of work, cost of consumables, labour charges etc. complete.	CM LENGTH	2.65
0523	Tightening of loosened bolts & nuts of all connections of steel structures such as columns, truss girders, trusses, crane girders, bracings, purlins etc. of buildings at all heights. Rate includes drilling holes wherever required, providing/replacement of bolts and nuts, (excluding cost of bolts and nuts), labour etc. Payment will be made based on the corresponding floor area of the buildings.	SQM	12.60
0524	Labour charges for making and fixing M.S fan hook of standard shape using M.S bar bent to shape with hooked ends in RCC slabs during laying including painting the exposed portion etc. complete. M.S bar will be supplied by BHEL at Stores at free of cost.	EACH	26.60
0525	Labour charges for making and fixing M.S fan hook of standard shape using M.S bar bent to shape with hooked ends in existing RCC slabs including cutting chase and making good to match with the existing one and painting the exposed portion of the hook etc. complete. M.S bar will be supplied by BHEL at Stores at free of cost.	EACH	172.70
0526	Removing cobwebs from the structures of buildings at all heights including cleaning of roof walls, undersurface of A.C sheets etc, complete. Rate includes providing working platforms, ladder, safety nets, labour etc, complete. Payment will be made based on the floor area of the buildings.	SQM	5.20

Item No.	Description	Unit	Rate (Rs.P)
0527	Supply and fixing rolling shutters of approved make, made of 80 x1.25 mm M.S laths with 1.25 mm thick top cover interlocked together through their entire length and joined together at end by end locks mounted on specially designed pipe shaft with brackets, side guides and arrangements for inside and outside locking with push and pull operation etc.complete including cost of providing and fixing necessary 27.5 cm long wire springs grade No.2 and M.S top cover of required thickness for rolling shutter.	SQM	1912.65
0528	Providing and fixing ball bearing for rolling shutters.	EACH	413.30
0529	Extra for providing mechanical device chain and crank operation for operating rolling shutters.		
A	Exceeding 10.00 SQM and upto 16.80 SQM in area.	SQM	630.25
B	Exceeding 16.80 SQM in area.	SQM	663.25
0530	Conveying from BHEL stores to site of work and fixing rolling shutters in proper position, all as directed by the Engineer-in-charge. Rate includes loading, leading, unloading and fixing of roller shutter including side brackets, gear box, lubricating the bearings etc., complete and making it fit for operation. Labour charges only.	SQM	276.60
0531	Providing and fixing in position of collapsible steel shutters with vertical channels 20 x 10 x 2 mm and braced with flat iron diagonals 20 x 5 mm size with top and bottom rail of T-iron 40 x 40 x 6 mm with 40 mm dia steel pulleys complete with bolts, nuts, locking arrangements, stoppers, handles, including applying a priming coat of approved steel primer.	SQM	4344.00
0532	Providing and fixing factory made ISI marked steel glazed doors, windows and ventilators, side / top / centre hung, with beading and all members such as F7D, F4B, K11 B and K12 B etc. complete of standard rolled steel sections, joints mitred and flash butt welded and sash bars tenoned and riveted, including providing and fixing of hinges, pivots, including priming coat of approved steel primer , but excluding the cost of other fittings, complete all as per approved design. Fixing with 15x3 mm lugs 10 cm long embedded in cement concrete block 15x10x10 cm of C.C. 1:3:6 (1 Cement : 3 coarse sand : 6 graded stone aggregate 40 mm nominal size).	SQM	1154.70
0533	Fixing standard steel glazed doors, windows and ventilators in walls with 15 x 3 mm lugs 10 cm long embedded in cement concrete blocks 15 x10 x10 cm of 1:3:6 or with wooden plugs and screws or rawl plugs and screws or with fixing clips or with bolts and nuts as required, including fixing of glass panes with glazing clips and special metal-sash putty or metal beading with screws. (Only steel doors, windows and ventilators with lugs, glass panes cut to size and glazing clips or metal beading with screws shall be supplied by BHEL at Stores at free of cost)	SQM	271.25

Item No.	Description	Unit	Rate (Rs.P)
0534	Supply and fixing of glass panes with putty, glazing clips etc. for steel doors, windows, ventilators etc. Rate includes removal of broken glasses and old putty.		
A	3 mm pin headed glass panes.	SQM	600.75
B	4 mm plain glass panes.	SQM	665.80
0535	Providing putty for glass panes. Rate includes removal of old putty, supply & applying new putty in a proper manner & required quantity at site of work, all as per instructions of Engineer in charge.	RM	19.30
0536	Providing and fixing in proper position of fan hook using 10 mm FSICHER SLM-N heavy duty ANCHOR fastener with clamp & bolts in the existing RCC roof slab. Rate includes cost of fan hook (fastener), drilling with power drilling machine to the required dia & depth in the RCC roof slab, inserting and fixing the fan hook in proper position, all labour and all other incidentals etc. complete.	EACH	390.50
0537	Providing and fixing oxidised M.S handle with necessary screws etc.complete.		
A	100 mm size	EACH	22.45
B	125 mm size	EACH	25.95
0538	Providing polyester sun control film of approved brand (GARWARE or equivalent) and shade to glazed panels in doors / windows / ventilators / partitions etc.with proper adhesive, all after removing the existing damaged film if available etc. complete. All as per instructions of Engineer in charge. Rate includes cost of all materials, scaffolding charges, labour, all other incidentals etc., complete.		
A	Non reflective Type - Regular grade	SQM	420.15
B	Non reflective Type - Premium Grade with Scratch Resisting Coating	SQM	1011.95
0539	Supply of Mild Steel sections such as channels, angles, T sections, flats, sheets, square bars, rods, tubes etc.at site of work and fabrication of steel work for gates, Y angles, purlins, trusses, any other small structures etc., all as per required design & drawing and erecting/fixing the same in proper alignment/position, level including site welding and or bolting/rivetting with necessary accessories such as keelmulai, keelpattai, hinges, tower bolts, aldrops etc.complete. Rate also includes providing two coats of synthetic enamel paint over one coat of red oxide primer. Payment will be made for the entire finished item of work.	MT	72332.55

Item No.	Description	Unit	Rate (Rs.P)
0540	Providing and fixing factory made ISI marked steel Paneled doors, windows and ventilators, side / top / centre hung, with beading and all members such as F7D, F4B, K11 B and K12 B etc. complete of standard rolled steel sections, joints mitred and flash butt welded and sash bars tenoned and riveted, including providing and fixing of hinges, pivots, including priming coat of approved steel primer , but excluding the cost of other fittings, complete all as per approved design.,and providing and fixing 18 gauge MS sheets for panes, handles, peg stays, friction throw hinges etc., complete including a priming coat of approved steel primer. Rate includes dismantling the masonry and making good all damages etc., complete.	SQM	2139.95
0541	Conveying the Gantrail MKVII 122 mm wide steel reinforced vulcanized rubber pad from BHEL stores to site of work and lifting the same to EOT crane girder level, laying, aligning and fixing in proper position along the top of crane girder at 8.00 m from floor level including sizing and correct to alignment by using chisel and filing the edges to match with the adjoining pad. Rate includes all labour, tools & plants and all other incidentals etc., complete.	R.M	91.50
0542	Conveying the Gantrail weldable base type 9116/10/32 adjustable crane rail clip including captive bolts, nuts, washers and integral vulcanized rubber nose from BHEL stores to site of work, lifting to EOT crane girder level and fixing them by welding using special electrodes to hold the EOT crane rail in correct level and alignment. Rate includes all labour, scaffolding, tools & plants, tightening the clamps after rail erection etc., complete and all other incidentals. Special electrodes and power will be supplied by BHEL at free of cost.	SET	137.25
0543	Supply, drilling and driving 10/12 mm dia anchor fasteners of length not exceeding 125 mm at 500 mm both sides of crane rail having tensile & shear capacity of minimum 1.50 MT into the RCC crane girder as indicated in the drawing to secure cover plate rigidly with the crane girder. Rate includes cost of fasteners, labour for drilling holes, etc., complete, all as per the instructions of Engineer-in-charge. Rate also includes provision for wastage of fasteners or repeat work in driving of fasteners due to infringement of reinforcement if any and also filling up the unwanted holes drilled on concrete girder due to repeat work with suitable high strength non-shrink cement.	SET	186.90
0544	Removing the old rigidly welded rail clamp and bolt by gauging the welded joint without damaging the bolt. Rate includes labour, consumables, tools & plants and making good all damages by welding and grinding the top surfaces of girder.	SET	52.15
0545	Lifting the gantry rails up to 200 mm and packing the rails/sleepers with ballast metal /shim. Plates true to span, alignment and level including oiling and tightening the fish bolts and sleepers, fasteners and fixing new fasteners for the missing and sectioning the formation to the required profile, all as per the instructions of Engineer-in-charge. (Ballast metal, shim, oil, new fasteners etc. will be supplied by BHEL at stores at free of cost) Payment will be made per metre length of single rail.	RM	40.05

Item No.	Description	Unit	Rate (Rs.P)
0546	Providing fibre glass reinforcement with UV resistant polyurethane compound lining, to a minimum thickness of 3 mm on newly fabricated M.S gutters at floor level and jointing and filling the gap finishing etc., after erection at a height ranging from 12-24m from FFL, and making the gutters leak proof as per instructions of Engineer-in-charge. The work consists of thoroughly cleaning the surface of the gutters and applying an undercoat of resin over which the alternate layers(min. three layers) of fibre strand & resin to the required thickness before applying polyurethane compound coating at top with one coat of Gel coat with surface mat and polish to provide even surface, preparation of surface with fibre reinforced plastic with 50 microns thick polyurethane lining, testing, etc., complete all as per instruction of Engineer-in-charge. Rate quoted shall also include cost of labour, material with all taxes, scaffolding charges, if any and all other incidental charges etc., complete.	SQM	956.40
0547	Providing fibre glass reinforcement with UV resistant polyurethane compound lining, to a minimum thickness of 3 mm on M.S gutters of factory buildings at a height ranging from 12-24m from FFL, and making the gutters leak proof as per instructions of Engineer-in-charge. The work consists of removing the adjoining North light Glazing, Roofing Sheets and existing paint in the gutter completely and thoroughly cleaning the surface including the damaged portion of the gutters and applying an undercoat of resin over which the alternate layers(min. three layers) of fibre strand & resin to the required thickness before applying polyurethane compound coating at top with one coat of Gel coat with surface mat and polish to provide even surface, preparation of surface with fibre reinforced plastic with 50 microns thick polyurethane lining, testing, refixing the removed north light glazing and Roofing sheets and also filling with fibre reinforcement prior to lining in areas badly worn out both in the bottom as well as sides of gutters etc., complete all as per instructions of Engineer- in –charge. Rate quoted shall also include cost of labour, material with all taxes, scaffolding charges, if any and all other incidental charges etc., complete (The Contractor is required to take all safety precautions during working and obtain work permit from the concerned departments. Working hour is restricted as it depends on shutdown by production department that may not be more than 4 hours at a stretch and only intermittent).	SQM	1259.20
0548	Supplying and laying rubberized and coloured (for 5mm thick layer) inter locking paver block of 50mm thickness M25 grade in flooring / pavement to take care of vehicular movements with proper line, level, alignment etc., all as per standard specification and instructions of Engineer-in-charge. The rate included cost of material, transportation, loading, unloading at site, labour for spreading and laying of paver block etc., complete over the sand bed of required thickness which will be paid under separate item.	SQM	894.40

Item No.	Description	Unit	Rate (Rs.P)
0549	Welding of 90 Lbs/CR 80 rail joints erected already in alignment in crane girders/gantry girder upto +14.00 meter including edge preparation, preheating welding using special type electrode (Elec grade 11018). The rate includes all labour charges, electrodes and incidental charges for dismantling the rail from its original position, edge preparation, preheating, welding, post heating as per the instructions of BHEL Engineer in charge. Also include cost of consumables for pre heating and post heating and labour charges for re fixing the 90 Lbs/CR 80 rail to alignment, level after welding etc., complete.	JOINT	2170.30
0550	Renewing the bottom rail and/or top rubber of collapsible gate including making good all damages and applying priming coat of zinc chromate yellow primer of approved brand and manufacturer. Rate includes removing the collapsible gate from its position including the frames, replacing the wornout portions wherever necessary with suitable new M.S Tee sections etc. and refixing the collapsible gate and making good the damages in floor, wall etc.with cement concrete etc.complete. Payment will be made only on weight basis for the replaced new M.S sections.	K.G	116.50
0551	Renewing wrought iron or M.S wheel or roller of steel door or gate and fitting and fixing the same with necessary clamps, nuts and bolts/welding and erection etc.complete.		
	A Wheel 50 mm dia and below	EACH	113.65
	B Wheel above 50 mm dia	EACH	171.60
0552	Supply and fixing cup type rail clamp with fittings over the insert plate which is embedded in the concrete. Rate includes welding including cost of consumables, all labour and other incidentals etc. complete, all as per instructions of Engineer-in-charge.	EACH	252.45
0553	Collection from BHEL stores and transporting of rails CR 80/R 45 etc to the contractor's site fabrication shop, straightening the rails using Gim screw or any other equipments, preparation of edge for welding the rail joints as per drawing and erecting in position at all elevations (i.e, in floor or over the girders) using cup type rail clamps with fittings. The scope includes rail alignment after erection, fixing in position, welding the joints by using approved electrode (E 11018 for CR 80 & E7018 for R 45 rails), pre heating & post heating the joints, grinding the joints neatly etc as per drawings and instruction of Engineer in charge.Rate shall include cost of providing one coat of red oxide primer as per IS specification and supply of DODL's for BHEL approval in compact disc with two copies of print outs. Quoted rate shall also include cost of consumables, hire charges for tools and plants, labour and incidentals etc complete but exclude cost of rails which will be supplied by BHEL at free of cost.	MT	11500.00

Item No.	Description	Unit	Rate (Rs.P)
VI - FLOORING			
0601	Finishing the top of all floors with 20 mm thick cement concrete (without using sand) in the proportion of one part of cement and three parts of 3 to 10 mm gauge hard broken granite stone chips and finishing the top surface smooth, rounding of corners, curing etc., complete, all as per standard specifications. (Ellis pattern I sort) Cement Consumption- 11.70 K.G /SQM	SQM	190.70
0602	Finishing the top of all floors with 20 mm thick cement concrete (without using sand) in the proportion of one part of cement and three parts of 3 to 10 mm gauge hard broken granite stone chips including mixed well with red oxide powder of approved quality of weight equal to one tenth of the weight of cement used. and finishing the top surface smooth, rounding of corners, curing etc., complete, all as per standard specifications. (Ellis pattern I sort). Cement Consumption -11.70 K.G/SQM	SQM	383.75
0603	Finishing the top of all floors with 25 mm thick cement concrete (without using sand) in the proportion of one part of cement and three parts of 3 to10 mm gauge hard broken granite stone chips, finishing the surfaces smooth, rounding of corners, curing, providing borders etc., complete, all as per standard specifications. (Ellis pattern flooring) Consumption of cement -14.60 K.G/SQM	SQM	235.10
0604	Finishing the top of all floors with 25 mm thick cement concrete (without using sand) in the proportion of one part of cement and three parts of 3 to10 mm gauge hard broken granite stone chips including mixed well with red oxide powder of approved quality of weight equal to one tenth of the weight of cement used. , finishing the surfaces smooth, rounding of corners, curing, providing borders etc., complete, all as per standard specifications. (Ellis pattern flooring). Consumption of cement -14.60 K.G/SQM	SQM	476.00
0605	Providing red oxide skirting for walls, etc. with cement mortar 1:3, 12 mm thick, well mixed with red oxide powder of approved quality of 3.50 K.G per 50 K.G of cement used, finishing, polishing the surfaces smooth, curing etc., complete, all as per standard specifications. Consumption of cement - 7.35 K.G/SQM	SQM	161.45
0606	Flooring with reinforced cement concrete of mix 1:2:4 using 40 mm and down graded hard broken granite stone jelly for thickness varying from 100 to 500 mm laid in panels not exceeding 6 x 30 m between expansion joints, including necessary vibration using needle / board / screed vibrators, all as required including necessary shuttering, painting the sides with bitumen, but excluding fabrication charges for reinforcement, all as per standard specifications. Cement consumption - 320.00 K.G/CUM	CUM	1942.05

Item No.	Description	Unit	Rate (Rs.P)
0607	Floor finish with 40 mm thick granolithick flooring over the concrete base while it is wet for proper bonding, the bottom 25 mm thick consisting of one part of cement and one part of 6 mm gauge hard broken granite stone chips (the proportion being by volume) and the top 15 mm finished with hardening compound of proportion one part of hardonate (ironite or equivalent) four parts of cement and eight parts of 6 mm gauge blue granite stone chips (the proportion being by weight) including finishing and painting the sides with bitumen etc., complete, all as per standard specifications. Cement consumption - 40 K.G/SQM	SQM	425.15
0608	Floor finish with 40 mm thick over concrete base while it is wet for proper bonding. 40 mm thick finish consists of one part of cement and one part of 6 mm gauge hard broken granite stone chips (the proportion being by volume) and finished smooth including painting the sides with bitumen etc., complete, all as per standard specifications. Cement consumption - 57.60 K.G/SQM	SQM	333.70
0609	Providing, laying and finishing the top of floor / side walls with 20 mm thick mosaic tiles of approved make and quality over a bed of cement slurry @ 4.40 Kg/SQM and a backing layer of cement mortar 1:4, 20 mm thick and tiles being joined, polished and finished smooth with necessary borders etc., complete including thorough cleaning of the surface before and after laying the tiles. All as per standard specifications. (Cost of tile shall include cost of cement for casting.)		
A	For gray colour Cement consumption - 12.90 K.G/SQM	SQM	472.70
B	For colours other than gray Cement consumption - 12.90 K.G/SQM	SQM	527.75
0610	Finishing the top of floors / sides of walls with insitu mosaic comprising of a bedding layer of cement mortar 1:4, 12 mm thick followed by 20 mm thick mosaic wearing layer comprising of cement and mosaic chips of 6 mm and down graded in proportion of 1:2, laid, polished and finished with necessary borders etc., complete including thorough cleaning the surfaces before and after laying the finish, all as per standard specifications.		
A	Gray colour Cement consumption - 5.11 K.G/SQM	SQM	465.55
B	For colours other than gray Cement consumption - 5.11 K.G/SQM	SQM	520.55
0611	Grinding and wax polishing of old mosaic floors, dado, skirting etc. in gray and all colours and finishing the surfaces smooth including filling the joints and voids by matching pigments, chips etc., complete, all as per standard specifications. Rate includes cost of materials, hire and running charges of machines, labour etc., complete.	SQM	77.25

Item No.	Description	Unit	Rate (Rs.P)
0612	Providing and laying Ceramic tiles of required size and minimum thickness of 6 mm in flooring, treads of steps and landings laid over a bed of cement slurry @ 3.30 Kg/SQM and a backing layer of 10 mm thick cement mortar 1:3, finished with flush pointing in white cement etc.complete, all as per standard specifications.		
A	For Plain Ceramic tile of Size 305mm X 305mm X 6mm of all Colours Cement consumption - 9.42 K.G/SQM	SQM	1035.20
B	For Plain Ceramic tile of Size 200mm X 200mm X 6mm of all Colours Cement consumption - 9.42 K.G/SQM	SQM	1053.70
C	For First Quality Design Ceramic tile of Size 305mm X 305mm X 6mm of all Colours Cement consumption - 9.42 K.G/SQM	SQM	1215.40
D	For First Quality Design Ceramic tile of Size 200mm X 200mm X 6mm of all Colours Cement consumption - 9.42 K.G/SQM	SQM	1299.90
0613	Providing and laying minimum 5 mm thick ceramic glazed floor tiles of first quality approved make confirming to IS:15622 and in all colours of required sizes in flooring, treads of steps, landings etc., laid over a bed of cement slurry @ 3.30 Kg/SQM and a backing layer of 12 mm thick cement mortar 1:3, finished with flush pointing in white cement using appropriate colour pigment etc. complete, all as per standard specifications. Cement consumption - 12.42 K.G/SQM	SQM	672.55
0614	Providing and fixing 1st quality ceramic glazed wall tiles conforming to IS : 15622 (thickness to be specified by the manufacturer), of approved make, in all colours, shades as approved by Engineer-in- Charge, in skirting, risers of steps and dados, over 12 mm thick bed of cement mortar 1:3 (1 cement : 3 coarse sand) and jointing with grey cement slurry @ 3.3 kg per sqm, including pointing in white cement mixed with pigment of matching shade complete Cement consumption - 12.42 K.G/SQM	SQM	672.55
0615	Providing and laying ceramic glazed floor tiles (of required thickness) of first quality approved make confirming to IS:15622 and in all colours of required sizes in flooring, treads of steps, landings etc., laid over a bed of cement slurry @ 3.30 Kg/SQM and a backing layer of 20 mm thick cement mortar 1:4, finished with flush pointing in white cement using appropriate colour pigment etc. complete, all as per standard specifications. Cement consumption - 12.42 K.G/SQM	SQM	678.65

Item No.	Description	Unit	Rate (Rs.P)
0616	Providing and laying ceramic glazed wall tiles (of required thickness) of first quality of approved make conforming to IS:15622 and in all colours of required sizes in skirting, walls, risers of steps and dado laid over a bed of cement slurry @ 3.30 Kg/SQM and a backing layer of 12 mm thick cement mortar 1:3 plaster and joined with white cement using appropriate colour pigment etc.complete, all as per standard specifications. Cement consumption - 12.42 K.G/SQM	SQM	745.80
0617	Fixing glazed/ceramic/vitrified floor tiles with cement based high polymer modified quick set tile adhesive (water based) conforming to IS 15477, using 5 K.G adhesive per SQM of tile area, in average 3 mm thickness.	SQM	367.60
0618	Providing, laying and finishing the top of floor with the following best quality slabs of required sizes over a bed of cement slurry @ 4.40 Kg/SQM and a backing layer of cement mortar 1:4, 20 mm (average) thick, finished with flush pointing in white cement using appropriate colour pigment including rubbing and polishing wherever necessary etc. complete, all as per instructions of Engineer in charge and standard specifications.		
A	Kota stone slabs 20 to 25 mm thick polished Cement consumption - 14.91 K.G/SQM	SQM	1151.40
B	Cuddappah slabs 20 to 25 mm thick single side polished Cement consumption - 14.91 K.G/SQM	SQM	879.20
C	Shahabad slabs 20 to 25 mm thick single side polished - Tandur Gray Cement consumption - 14.91 K.G/SQM	SQM	851.95
D	Shahabad slabs 20 to 25 mm thick single side polished - Tandur Green Cement consumption - 14.91 K.G/SQM	SQM	838.35
E	Marble slabs 16 to 18 mm thick, polished - Rajnagar plain white Cement consumption - 13.51 K.G/SQM	SQM	1219.90
F	Marble slabs 16 to 18 mm thick, polished - Green (Udaipur) colour Cement consumption - 13.51 K.G/SQM	SQM	1333.75
G	Marble slabs 16 to 18 mm thick, polished - Pink colour Cement consumption - 13.51 K.G/SQM	SQM	1276.85
H	Marble slabs 16 to 18 mm thick, polished - Black (Zebra/Galaxy) colour Cement consumption - 13.51 K.G/SQM	SQM	1093.40
I	Granite slabs 16 to 18 mm thick, polished - S.White Cement consumption - 13.51 K.G/SQM	SQM	1440.95
J	Granite slabs 16 to 18 mm thick, polished - Black (Andhra) Colour Cement consumption - 13.51 K.G/SQM	SQM	2298.45
K	Granite slabs 16 to 18 mm thick, polished - Gray Colour Cement consumption - 13.51 K.G/SQM	SQM	2026.20

Item No.	Description	Unit	Rate (Rs.P)
L	Granite slabs 16 to 18 mm thick, polished - Green Colour Cement consumption - 13.51 K.G/SQM	SQM	1958.15
M	Granite slabs 16 to 18 mm thick, polished - Sweet Green Colour Cement consumption - 13.51 K.G/SQM	SQM	2434.55
N	Granite slabs 16 to 18 mm thick, polished - Red (Gem) Colour Cement consumption - 13.51 K.G/SQM	SQM	1958.15
O	Granite slabs 16 to 18 mm thick, polished - Blue (Lavender) Colour Cement consumption - 13.51 K.G/SQM	SQM	2230.40
P	Granite slabs 16 to 18 mm thick, polished - Laga red Colour Cement consumption - 13.51 K.G/SQM	SQM	3659.60
Q	Granite slabs 16 to 18 mm thick, polished - Steel grey Colour Cement consumption - 13.51 K.G/SQM	SQM	1754.00
R	Vitrified Tiles of required thickness and 60 x 60 cm size (cement slurry is 3.30 Kg/SQM instead of 4.40 Kg/SQM) Cement consumption - 12.42 K.G/SQM	SQM	1228.35
S	Precast cement Concrete Tiles of approved make of minimum thickness 22mm and required size and pattern (cement slurry is 3.30 Kg/SQM instead of 4.40 Kg/SQM) Cement consumption - 12.42 K.G/SQM	SQM	495.50
0619	Providing, laying and finishing the top of floor with the following best quality tiles of required sizes over a bed of cement slurry @ 3.30 Kg/SQM and a backing layer of cement mortar 1:4, 20 mm (average) thick, finished with flush pointing in white cement using appropriate colour pigment including rubbing and polishing wherever necessary etc. complete, all as per instructions of Engineer in charge and standard specifications.		
A	Marble tiles (polished), 8 mm thick (approx.) - Rajnagar plain white/Green (Udaipur)/Black (Zebra) Cement consumption - 12.42 K.G/SQM	SQM	800.95
B	Granite tiles (polished), 8 to 10 mm thick (approx.) - P White Cement consumption - 12.42 K.G/SQM	SQM	873.75
C	Granite tiles (polished), 8 to 10 mm thick (approx.) - Gray (Steel) Colour Cement consumption - 12.42 K.G/SQM	SQM	837.35
D	Granite tiles (polished), 8 to 10 mm thick (approx.) - Red (Gem) Colour Cement consumption - 12.42 K.G/SQM	SQM	934.40
E	Granite tiles (polished), 8 to 10 mm thick (approx.) - Green Colour Cement consumption - 12.42 K.G/SQM	SQM	970.80

Item No.	Description	Unit	Rate (Rs.P)
F	Granite tiles (polished), 8 to 10 mm thick (approx.) - Sweet Green Colour Cement consumption - 12.42 K.G/SQM	SQM	1261.95
G	Granite tiles (polished), 8 to 10 mm thick (approx.) - Black (Galaxy) Colour Cement consumption - 12.42 K.G/SQM	SQM	970.80
H	Granite tiles (polished), 8 to 10 mm thick (approx.) - Laga Red Colour Cement consumption - 12.42 K.G/SQM	SQM	1541.00
I	Granite tiles (polished), 8 to 10 mm thick (approx.) - Raw Silk Colour Cement consumption - 12.42 K.G/SQM	SQM	873.75
J	Granite tiles (polished), 8 to 10 mm thick (approx.) - Steel Grey Colour Cement consumption - 12.42 K.G/SQM	SQM	837.35
0620	Stone tile work of 8 mm thick (mirror polished and machine cut edge). for wall lining upto 10 m height with special adhesive over 12 mm thick bed of cement mortar 1:3 (1 cement : 3 coarse sand), including pointing in white cement with an admixture of pigment to match the stone shade.		
A	Granite tiles (Polished) - Jet Black Cement consumption - 10.44 K.G/SQM	SQM	1691.95
B	Granite tiles (polished), 8 to 10 mm thick (approx.) - Red (Gem) Colour Cement consumption - 10.44 K.G/SQM	SQM	1342.20
C	Granite tiles (polished), 8 to 10 mm thick (approx.) - Green Colour Cement consumption - 10.44 K.G/SQM	SQM	1378.60
D	Granite tiles (polished), 8 to 10 mm thick (approx.) - Black (Galaxy) Colour Cement consumption - 10.44 K.G/SQM	SQM	1378.60
E	Granite tiles (polished), 8 to 10 mm thick (approx.) - Steel Grey Colour Cement consumption - 10.44 K.G/SQM	SQM	1245.15
F	Marble tiles (polished), 8 mm thick (approx.) - Rajnagar plain white/Green (Udaipur)/Black (Zebra) Cement consumption - 10.44 K.G/SQM	SQM	1208.75
0621	Stone tile (polished) work of 8mm thick for wall lining over 12 mm thick bed of cement mortar 1:3 (1 cement : 3 coarse sand) and cement slurry @ 3.3 kg/sqm including pointing in white cement complete with the following		
A	Granite tiles (Polished), 8 to 10 mm thick (approx.) - Jet Black Cement consumption - 10.44 K.G/SQM	SQM	1855.75
B	Granite tiles (polished), 8 to 10 mm thick (approx.) - Red (Gem) Colour Cement consumption - 10.44 K.G/SQM	SQM	1506.00

Item No.	Description	Unit	Rate (Rs.P)
C	Granite tiles (polished), 8 to 10 mm thick (approx.) - Green Colour Cement consumption - 10.44 K.G/SQM	SQM	1542.40
D	Granite tiles (polished), 8 to 10 mm thick (approx.) - Black (Galaxy) Colour Cement consumption - 10.44 K.G/SQM	SQM	1542.40
E	Granite tiles (polished), 8 to 10 mm thick (approx.) - Steel Grey Colour Cement consumption - 10.44 K.G/SQM	SQM	1408.95
F	Marble tiles (polished), 8 mm thick (approx.) - Rajnagar plain white/Green (Udaipur)/Black (Zebra) Cement consumption - 10.44 K.G/SQM	SQM	1372.55
0622	Mirror polishing on marble work/granite work/stone work wherever required to give high gloss finish etc.complete.	SQM	162.20
0623	Extra for prefinished nosing to treads of steps of marble stones.	RM	219.00
0624	Extra for prefinished nosing in treads of steps of kota stones.	RM	70.90
0625	Supply and fixing homogeneous PVC sheets / tiles of approved brand, pattern, colour, shade & manufacture in flooring / skirting on a smooth and damp proof base using rubber based adhesives of approved quality including rolling with light wooden roller weighing about 5 K.G. etc.complete, all as per standard specifications.		
A	1.5 / 1.6 mm thick	SQM	422.05
B	2 mm thick	SQM	618.40
0626	Supply and laying roughly dressed cut stone slabs of required sizes and thickness over sand bed or mortar bed, excluding pointing, all as per standard specifications. Rate excludes cost of sand bed/mortar bed.	CUM	4330.90
0627	Labour charges for edge preparation (NOZING) and polishing of the laid granite slab on the working platform, table etc. , The rate includes charges for required grinding machine, labour etc., complete. All as per the instructions of Engineer-in-charge	R.M	181.95
0628	Flooring with reinforced cement concrete of mix 1:2:4 using 20 mm and down graded hard broken granite stone jelly for thickness varying from 100 to 500 mm laid in panels not exceeding 6 x 30 m between expansion joints, including necessary vibration using needle / board / screed vibrators, all as required including necessary shuttering, painting the sides with bitumen, but excluding fabrication charges for reinforcement, all as per standard specifications. Cement consumption - 320.00 K.G/CUM	CUM	2119.70

Item No.	Description	Unit	Rate (Rs.P)
VII - ROOFING			
701	Carrying , hoisting and fixing in position of 0.47 to 0.50mm thick colour coated Aluminium zinc alloy coated high tensile steel rib profile sheets with accessories such as ridge pieces, barge boards, North light curves, end curves, etc., for roofing at all heights with necessary xylon coated self tapping / self drilling screws with EPDM washers at every ribs etc., complete. All as per drawings, manufacturers specifications and instructions of Engineer-in-charge .Rate includes cost of self tapping/ self drilling screws with EPDM washers etc., and labour charges for fixing, hire charges for tools and plants like drilling machines, cost of providing life line and other provisions for safety, scaffolding and all other incidental charges etc., complete but excluding cost of Aluminium zinc alloy coated high tensile steel sheets and its accessories such as ridge pieces, barge boards, curves, etc., which will be supplied by BHEL at Stores at free of cost. The payment will be made for the actual laid area only.	SQM	88.60
702	Carrying , hoisting and fixing in position of 0.47 to 0.50mm thick colour coated Aluminium zinc alloy coated high tensile steel rib profile sheets with accessories such as ridge pieces, barge boards, curves, etc., for side sheeting at all heights with necessary xylon coated self tapping / self drilling screws with EPDM washers at every valleys, etc., complete .All as per drawings, manufacturers specifications and instructions of Engineer-in-charge ..Rate includes cost of self tapping/ self drilling screws with EPDM washers etc., and labour charges for fixing, hire charges for tools and plants like drilling machines, cost of providing life line and other provisions for safety, scaffolding and all other incidental charges etc., complete but excluding cost of Aluminium zinc alloy coated high tensile steel sheets and its accessories such as ridge pieces, barge boards, curves, etc., which will be supplied by BHEL at Stores at free of cost. The payment will be made for the actual laid area only.	SQM	114.35
703	Supplying at site of work , hoisting and fixing in position of 0.47 to 0.50mm thick colour coated Aluminium zinc alloy coated high tensile steel rib profile sheets with accessories such as ridge pieces, barge boards, North light curves, end curves, etc., as per technical specifications given in note below for roofing at all heights with necessary xylon coated self tapping / self drilling screws with EPDM washers at every ribs etc., complete. All as per drawings, manufacturers specifications and instructions of Engineer-in-charge .Rate includes cost of all materials like colour coated Aluminium zinc alloy coated high tensile steel rib profile sheets with accessories such as ridge pieces, barge boards, curves, etc., wherever required self tapping / self drilling screws with EPDM washers at every ribs etc., and labour charges for fixing, hire charges for tools and plants like drilling machines, providing lifeline and other provisions for safety, and all other incidental charges etc., complete. The payment will be made for the actual laid area only. Note: (1)The Aluminium zinc alloy coated high tensile steel sheets and specials shall be 0.47 to 0.50mm thick (TCT) (Aluminium around 55%, Zinc around 43%) alloy coated high tensile steel (Yield strength 550 MPA) colour coated rib profile sheets as per ASTM A792M, coating standard as per AS 1397-1933 Conforming to AZM 150 (Min Coating mass of 150 gsm) having cover width of 1000 plus or minus 10mm and over all width of 1060mm of any length to suit site conditions	SQM	559.80

Item No.	Description	Unit	Rate (Rs.P)
704	<p>(2) About 90% area of the Aluminium zinc alloy coated high tensile steel sheets shall be colour coated with Light Blue RAL 5012 and 10% of the covered area is of with off white. All ridge pieces and barge boards are of white.</p> <p>(3) The Aluminium zinc alloy coated high tensile steel sheets shall be Pre-Primed with a Primer of 5µm and finished with a final paint coat of 17-20 µm on top surface. A single backing coat of 7-10µm should be applied on reverse side</p> <p>Supplying at site of work , hoisting and fixing in position of 0.47 to 0.50mm thick colour coated Aluminium zinc alloy coated high tensile steel rib profile sheets with accessories such as ridge pieces, barge boards, curves, etc., as per technical specifications given in note below for side sheeting at all heights with necessary xylon coated self tapping / self drilling screws with EPDM washers at every valleys, etc., complete .All as per drawings, manufacturers specifications and instructions of Engineer-in-charge .Rate includes cost of all materials like colour coated Aluminium zinc alloy coated high tensile steel rib profile sheets with accessories such as ridge pieces, barge boards, curves, self tapping / self drilling screws with EPDM washers at every valleys, etc., and labour charges for fixing, hire charges for tools and plants like drilling machines, providing lifeline and other provisions for safety, and all other incidental charges etc., complete. The payment will be made for the actual laid area only.</p> <p>Note: (1)The Aluminium zinc alloy coated high tensile steel sheets and specials shall be 0.47 to 0.50mm thick (TCT) (Aluminium around 55%, Zinc around 43%) alloy coated high tensile steel (Yield strength 550 MPA) colour coated rib profile sheets as per ASTM A792M, coating standard as per AS 1397-1933 Conforming to AZM 150 (Min Coating mass of 150 gsm) having cover width of 1000 plus or minus 10mm and over all width of 1060mm of any length to suit site conditions</p>	SQM	585.60
705	<p>(2) About 90% area of the Aluminium zinc alloy coated high tensile steel sheets shall be colour coated with Light Blue RAL 5012 and 10% of the covered area is of with off white. All ridge pieces and barge boards are of white.</p> <p>(3) The Aluminium zinc alloy coated high tensile steel sheets shall be Pre-Primed with a Primer of 5µm and finished with a final paint coat of 17-20 µm on top surface. A single backing coat of 7-10µm should be applied on reverse side</p> <p>Supplying at site of work, hoisting and fixing in position of 2mm thick embossed clear poly carbonate roof light sheets in specified locations and at all heights with necessary xylon coated self tapping / self drilling screws with EPDM washers at every ribs, etc., complete to match the profile of Aluminium zinc alloy coated high tensile steel roof sheets, as per instructions of Engineer-in- charge. The rate includes cost of poly carbonate sheets ,self tapping / self drilling screws with EPDM washer, at every ribs, and labour charges, all scaffolding charges, tools and plants and all other incidental charges etc., complete</p>	SQM	1540.90

Item No.	Description	Unit	Rate (Rs.P)
706	Supplying roof extractors (Turbo Air Ventilators) of dia 600mm or thereabouts, fixing in position on AC / Aluminium zinc alloy coated high tensile steel sheet roofs at all heights with necessary screws,, bolts etc., and finishing to match with existing roof. Rate to include cost of all labour charges for fixing the roof extractors with necessary cutting of sheets to the required size ,drilling to suit the screws/ bolts, and finishing to match the existing profile including cost of roof extractors / ventilators. All as per manufacturers specifications and as directed by the Engineer in charge	EACH	8800.00
0707	Supply and fixing corrugated fibre glass reinforced polyester translucent roof light sheets of all colours including white of following thickness to match with the existing A.C. sheet roofing including cost of G.I. bolts, nuts, washers and bitumen washers etc., complete. Payment will be based on the laid area.		
A	FRP Sheet 1 mm thick	SQM	474.60
B	FRP Sheet 2 mm thick	SQM	791.80
0708	Supply and fixing in position of galvanised iron plain sheets of 1.60 mm thick for flashing using G.I bolts, nuts, limpet washers etc. complete bent to shape and fixed in walls with cement mortar 1:3, all as per drawings and specifications.	SQM	824.75
0709	Conveying G.I sheets from BHEL stores to site of work, bent to shape and fixing in proper position for flashing fixed with G.I bolts, nuts, limpet washers etc., complete and fixed in walls with cement mortar 1 : 3, all as per drawings and specifications. G.I sheet alone will be supplied by BHEL at Stores at free of cost.	SQM	445.05
0710	Supply and fixing in position of 6 mm thick wired glass in roof north light glazing including straightening the aluminium astrangle as required. Rate includes cost of glass, labour etc. complete.	SQM	988.70
0711	Conveying from BHEL stores to site of work 6 mm thick wired glass and fixing in position for roof north light glazing including straightening the aluminium astrangle as required. Rate includes labour, conveyance and other incidentals, removing the broken glasses from its position etc.complete.	SQM	102.25
0712	Providing weathering course on top of roof slab with 20 mm size brick jelly and pure lime (no sand) in the proportion of 32 : 12.5 to the required thickness, well beaten with wooden battens, so as to secure adequate slope, all as per standard specifications and instructions of Engineer-in-charge.	CUM	3061.05

Item No.	Description	Unit	Rate (Rs.P)
0713	Providing weathering course on top of roof slab with one course of split tiles or pressed flat tiles of 17 to 20 mm thick and of approved brand & size, set in cement mortar 1:3 with an admixture of crude oil at 10% by weight of cement, 12 mm thick bedding layer including pointing the tiles with the same oiled mortar etc., complete, all as per standard specifications.	SQM	373.30
	Cement consumption - 9.13 K.G/SQM		
0714	Labour charges for repairing the weathering course tiles. Scope includes cleaning the surfaces by removal of vegetation growth, dry leaves etc., racking out the tile joints, replacing the damaged tiles wherever necessary with new ones supplied by department, pointing the tiles with cement mortar 1:3 and applying mendo non-tar plast cement over the pointed surfaces. (Tiles and mendo non tar plast cement will be supplied by BHEL at stores at free of cost.)	SQM	118.60
0715	Labour charges for repairing the weathering course tiles. Scope includes cleaning the surfaces by removal of vegetation growth, dry leaves etc., racking out the tile joints, replacing the damaged tiles wherever necessary with new ones supplied by department, pointing the tiles with cement mortar 1:3 and applying mendo non-tar plast cement over the pointed surfaces. (Only Tiles will be supplied by BHEL at stores at free of cost).	SQM	110.90
0716	Attending to leak at roof slab and wall joint, all as per instructions of Engineer-in-charge. Rate includes dismantling the weathering course tiles, brick jelly lime concrete etc. for a width of minimum 100 mm at wall and slab joint for required depth so as to reach the top surface of roof slab, finishing with cement concrete in the proportion of one part of cement & three parts of 6 mm stone chips in the dismantled portion with bitumen compound filler at joint and top, finished with tiles at 1 : 1 slope along with walls including hacking walls, replacing the damaged tiles, pointing with CM 1:3 etc. complete. Cement, tiles and bitumen compound will be supplied by BHEL at stores at free of cost.	RM	176.40
0717	Attending to leak at roof slab and wall joint, all as per instructions of Engineer-in-charge. Rate includes dismantling the weathering course tiles, brick jelly lime concrete etc. for a width of minimum 100 mm at wall and slab joint for required depth so as to reach the top surface of roof slab, finishing with cement concrete in the proportion of one part of cement and three parts of 6 mm stone chips in the dismantled portion with bitumen compound filler at joint and top, finished with tiles at 1 : 1 slope along with walls including hacking walls, replacing the damaged tiles, pointing with CM 1:3 etc. complete. The rate shall also include cost of tiles. Cement and bitumen compound will be supplied by BHEL at stores at free of cost.	RM	205.20

Item No.	Description	Unit	Rate (Rs.P)
0718	Providing weathering course on top of roof slab with one course of split tiles or pressed flat tiles of 17 to 20 mm thick of approved brand and size set in CM 1:3 with Roff plaster master plus solution (100 ml of plaster master liquid to be mixed with required quantity of water for one bag of cement), 12 mm thick bedding layer including pointing the tiles with same mortar etc. complete, all as per std. specifications. Roff plaster master and required tiles will be supplied by BHEL at Stores at free of cost.	SQM	354.05
0719	Same as per item No. 0718 but required tiles will also be supplied by BHEL at Stores at free of cost.	SQM	85.25
0720	Labour charges for removing the damaged weathering course tiles and laying with new tiles set in CM 1:3 with Roff plaster master water solution (100 ml of plaster master liquid to be mixed with required quantity of water for one bag of cement), 12 mm thick bedding layer including pointing the tiles with same mortar etc. complete, all as per standard specifications. Tiles and Roff plaster master will be supplied by BHEL at Stores at free of cost.		
A	1 to 5 tiles at one spot.	EACH	37.40
B	Beyond 5 but upto 10 tiles at one spot.	EACH	63.85
0721	Rectifying to the weathering course tile joints by scraping the old mortar joints to a minimum depth of 12 mm with wire brush and cleaning the surface of all dirt, loose mortar etc., pointing the grooved joints with CM 1:3 thoroughly mixed with Roff plaster master solution (100 ml. of plaster master liquid to be mixed with not more than 40 litre of water for one bag of cement), finishing the pointed joints smoothly, proper curing etc. complete. Roff plaster master liquid will be supplied by BHEL at Stores at free of cost.	SQM	101.30
0722	Rectifying to the corners between wall and roof slab by removing the brick work and concrete at least to a depth of 25 mm along the corners horizontally, clearing the opened corners off all dirt and filling with roofing bituminous compound pressed gently to form smooth concaved corners and finishing the surface with CM 1:3, 12 mm thick for a maximum width of 25 cm, thoroughly mixed with Roff plaster master solution (100 ml Roff plaster master liquid to be mixed with not more than 40 litre of water for one bag of cement) to a neat finish. Bituminous compound & Roff plaster master liquid will be supplied by BHEL at Stores at free of cost.	RM	50.80

Item No.	Description	Unit	Rate (Rs.P)
0723	Conveying from BHEL stores to site of work, hoisting and fixing in position of 4 mm / 6 mm thick multi walled clear (UV coated) polycarbonate sheet for north light glazing runner (inclined & vertical) as per drawing including provision of suitable aluminium frames as required. The scope of work includes supply of aluminium frames (top & bottom) in required profiles fitted with EPDM rubber gaskets and fixing in the glazing runner using SDST screws of approved make and polycarbonate sheets are suitably placed between the aluminium frames before driving the top frame screws all as per Drg.no and as per the instructions of Engineer in Charge. The top and bottom portion of polycarbonate sheets shall be closed with aluminium U channels to prevent dust and insects. Rate shall include cost of aluminium frames, U channels, EPDM rubber gaskets, SDST screws required labour, tools & plants, etc., except polycarbonate sheets which will be supplied by BHEL at free of cost	SQM	1179.50
0724	To collect and cleaning of all the damaged north light glazing materials (polycarbonate sheets) at roof top for all heights and removing/repairing the north light glazing bars (aluminium beading) wherever required in line, level and alignment as per the instructions of Engineer in charge. The aluminium beadings and polycarbonate sheets shall be re fixed using 2 nos of 50mm X 6mm MS Hexagonal bolts, nuts & washersat top horizontal 8 nos of 35mm X 12mm Self drilling fasteners with EPDM washers at both the vertical sides and 2 nos of 50mm X 12mm self drilling screws with EPDM washers at bottom horizontal in each panel. The rate shall include cost of all labour charges, incidental charges for removing repairing and cost of all required fasteners for re fixing work but excludes cost of polycarbonate sheets and aluminium beading which will be supplied at free of cost. Payment will be made only for the actual area of repair work executed.	SQM	116.00
0725	Supplying at site of work, hoisting and fixing in position of 4 / 6mm thick multiwalled clear (UV coated) Polycarbonate sheet for north light glazing / glazing in monitor type roof to suit the rows of glazing runner (inclined and vertical) as per drawing including provision of suitable aluminium frames as required. The scope of work includes supply of polycarbonate sheets,aluminium frames (top & bottom) in required profile fitted with EPDM rubber gaskets and fixing in the glazing runner using SDST screws of approved make and the polycarbonate sheets are suitably placed between the aluminium frames before driving the top frame screws all as per standard specification , instructions of Engineer-in-charge. The top and bottom portion of polycarbonate sheets shall be closed with aluminium U channels to prevent dust and insects. Rate shall include cost of polycarbonate sheets, aluminium frames, U channels, EPDM rubber gaskets, SDST screws, required labour, tools and plants etc.,complete.	SQM	1800.00

Item No.	Description	Unit	Rate (Rs.P)
VIII - FINISHING			
0801	Plastering with cement mortar as per standard specifications.		
A	In cement mortar 1:3, 12mm thick Cement Consumption - 7.35 K.G/SQM	SQM	93.25
B	In cement mortar 1:4, 12mm thick Cement Consumption - 5.47 K.G/SQM	SQM	93.05
C	In Cement mortar 1:5, 12mm thick Cement Consumption - 4.46 K.G/SQM	SQM	92.95
D	In cement mortar 1:6, 12mm thick Cement Consumption - 3.60 K.G/SQM	SQM	92.85
E	In cement mortar 1:3, 15mm thick Cement Consumption - 8.77 K.G/SQM	SQM	107.30
F	In Cement mortar 1:4, 15mm thick Cement Consumption - 6.54 K.G/SQM	SQM	107.05
G	In Cement mortar 1:5, 15mm thick Cement Consumption - 5.33 K.G/SQM	SQM	106.90
H	In Cement mortar 1:6, 15mm thick Cement Consumption - 4.30 K.G/SQM	SQM	106.80
I	In Cement mortar 1:3, 20mm thick Cement Consumption - 11.42 K.G/SQM	SQM	125.20
J	In Cement Mortar 1:4, 20mm thick Cement Consumption - 8.51 K.G/SQM	SQM	124.90
K	In Cement mortar 1:5, 20mm thick Cement Consumption - 6.94 K.G/SQM	SQM	124.70
L	In Cement mortar 1:6, 20mm thick Cement Consumption - 5.60 K.G/SQM	SQM	124.60
0802	Damp proof course with cement mortar 1:3, 12 mm thick mixed with an admixture of crude oil at 5 % by weight of cement, all labour etc. complete as per standard specifications. Cement Consumption - 7.35 K.G/SQM	SQM	108.85
0803	Damp proof course with cement mortar 1:3, 20 mm thick mixed with an admixture of crude oil at 5 % by weight of cement, all labour etc. complete as per standard specifications. Cement Consumption - 11.42 K.G/SQM	SQM	149.35
0804	Damp proof course with cement mortar 1:3, 12 mm thick mixed with water proofing compound (Accoproof or Impermo or equivalent) at 1 Kg per 50 Kg of cement for water facing surfaces etc. complete., all as per standard specifications. Cement Consumption - 7.35 K.G/SQM	SQM	99.05

Item No.	Description	Unit	Rate (Rs.P)
0805	Damp proof course with cement mortar 1:3, 20 mm thick mixed with water proofing compound (Accoproof or Impermo or equivalent) at 1 Kg per 50 Kg of cement for water facing surfaces etc. complete., all as per standard specifications. Cement Consumption - 11.42 K.G/SQM	SQM	134.15
0806	Ceiling plastering with cement mortar 1:3, 6mm thick as per standard specifications. Cement Consumption - 3.67 K.G/SQM	SQM	82.10
0807	Plain cement mortar bands of 12 mm thick in cement mortar 1:4 to the specified width as per standard specifications. Cement Consumption - 5.32 K.G/SQM	SQM	228.85
0808	Stucco plastering 12 mm thick with cement mortar 1:3 (1 cement & 3 coarse aggregate of 6 to 12 mm size) over a backing plastering, all as per standard specifications. (Backing plaster will be paid for separately) Cement Consumption - 7.30 K.G/SQM	SQM	96.55
0809	Exposed aggregate plastering with crushed stone graded from 6 to 12 mm nominal size dashed over and including fresh plaster in cement mortar 1:3, 12mm thick over a backing coat of cement plaster (which will be paid separately), all as per standard specifications. Cement Consumption - 7.30 K.G/SQM	SQM	128.15
0810	Finishing the plastered surfaces with a floating coat of cement (punning), all as per standard specifications. Cement Consumption - 2.20 K.G/SQM	SQM	21.70
0811	Flush/Ruled pointing on stone work with cement mortar 1:3 as per standard specifications. Cement Consumption 1.17 K.G/SQM	SQM	114.05
0812	Pointing to rough stone dry packing in aprons and revetments including grouting to a depth of 40 mm with cement mortar 1:3, all as per standard specifications. Cement Consumption 1.84 K.G/SQM	SQM	62.90
0813	Flush pointing with cement mortar 1:3 for stone slab pavement or precast slab pavement or tiling works etc., all as per standard specifications. Cement Consumption 2.35 K.G/SQM	SQM	95.80
0814	Providing black board in walls in cement mortar 1:2 mixed with black oxide over rough plastered surface in cement mortar 1:4, 12 mm thick and providing 25 mm border around in cement mortar 1:3 neatly rounded including providing and fixing with teak wood beading 50 x 25 mm on top of board and hooks and chalk stand on the bottom of board etc., all as per standard specifications. Cement Consumption 13.20 K.G/SQM	SQM	836.30

Item No.	Description	Unit	Rate (Rs.P)
0815	White washing on surfaces using best shell lime to give an even shade including cleaning, brushing of walls and preparing surfaces in accordance with standard specifications. Rate includes cost of all materials, labour etc., complete.		
A	Three or more coats	SQM	10.55
B	Two coats	SQM	5.95
C	One coat	SQM	4.25
0816	White washing on surfaces using Janathacem or equivalent material to give an even shade including cleaning, brushing of walls and preparing surfaces in accordance with standard specifications. Rate includes cost of all materials, labour, curing etc., complete.		
A	Three coats	SQM	11.55
B	Two coats	SQM	7.00
C	One coat	SQM	4.25
0817	Colour washing such as green, blue or buff on surfaces to give an even shade including cleaning, brushing walls and preparing surfaces in accordance with standard specifications. Rate includes cost of all materials, labour, etc., complete.		
A	Two or more coats with a base coat of white washing with lime	SQM	13.70
B	Two coats	SQM	7.80
C	One coat	SQM	4.55
0818	Removing white or colour wash by scraping, sand papering and preparing the surfaces smooth including necessary repairs to scratches etc. complete.	SQM	5.50
0819	Applying one coat of cement primer of approved brand and manufacturer on wall surfaces.	SQM	29.25
0820	Painting walls with water proofing cement paint of approved brand and shade on surfaces to give an even shade including cleaning, preparing the surfaces, curing etc., complete.		
A	Three coats (A priming coat of cement primer & two coats of water proofing cement paint)	SQM	76.75
B	Two coats	SQM	47.50
C	One coat	SQM	30.00
0821	Painting with sandtex matt of approved brand and shade on surfaces to give an even shade including cleaning the surfaces of all dirt, dust and other foreign matters, sand papering and stopping, all as per standard specifications.		

Item No.	Description	Unit	Rate (Rs.P)
A	Three coats (A priming coat of approved cement primer and two coats of sandtex matt)	SQM	109.50
B	Two coats	SQM	79.10
C	One coat	SQM	46.45
0822	Applying one coat of distemper primer of approved brand and manufacture on wall surfaces.	SQM	30.35
0823	Distempering using oil bound washable distemper of approved brand and shade on surfaces including cleaning, brushing, preparing the surfaces even and sand papered smooth in accordance with standard specifications.		
A	Three coats (A priming coat with approved primer and two coats of distempering).	SQM	70.55
B	Two coats	SQM	40.20
C	One coat	SQM	27.35
0824	Painting with ready mixed plastic emulsion paint of approved brand and shade on surfaces to give an even shade including thorough scraping, removal of dirt, applying necessary plaster of paris, putty etc.complete, all as per standard specifications.		
A	Three coats (A priming coat with approved primer and two coats of plastic emulsion paint).	SQM	85.90
B	Two coats	SQM	55.55
C	One coat	SQM	37.55
0825	Painting with synthetic enamel paint of approved brand and shade on surfaces to give an even shade including cleaning the surfaces of all dirt, dust and other foreign matters, sand papering and stopping, all as per standard specifications.		
A	Three coats (A priming coat with approved primer and two coats of synthetic enamel paint).	SQM	97.90
B	Two coats	SQM	67.55
C	One coat	SQM	43.55
0826	Removing dry or oil bound distemper / water proofing cement paint / paint by scraping, sand papering and preparing the surfaces smooth including necessary repairs to scratches etc., complete.	SQM	7.25
0827	Varnishing with varnish of approved brand and manufacture to give an even shade, all as per standard specifications.		
A	Three coats (An under coat with flattening varnish and two coats of copal varnish)	SQM	93.35

Item No.	Description	Unit	Rate (Rs.P)
B	Two coats	SQM	62.60
C	One coat	SQM	40.95
0828	Polishing with french polish including a coat of wood filler to give an even surface, including cleaning the surfaces of all dirt, dust and sand papered smooth, all as per standard specifications.		
A	Two coats	SQM	180.30
B	One coat	SQM	94.25
0829	Painting with aluminium paint of approved brand and manufacture on surfaces to give an even shade, all as per standard specifications.	SQM	61.45
A	Two coats.		
B	One coat	SQM	39.15
0830	Painting with black anti corrosive bitumastic paint of approved brand and manufacture on surfaces to give an even shade, all as per standard specifications.		
A	Two coats.	SQM	45.55
B	One coat	SQM	30.60
0831	Painting with black board paint of approved brand and manufacture on surfaces to give an even shade, all as per standard specifications.		
A	Two coats.	SQM	59.85
B	One coat	SQM	38.75
0832	Lettering with paint of approved brand, shade and manufacture of 1 cm Height.		
A	In synthetic enamel paint	EACH	1.90
B	In black japan paint	EACH	1.85
0833	Painting one priming coat with approved primer on surfaces including preparing the surfaces by thoroughly cleaning oil, grease, dirt and other foreign matters and scoured with wire brushes, fine steel wool scrapers and sand paper, all as per standard specifications.		
A	Zinc Chromate primer	SQM	28.35
B	Red oxide primer	SQM	20.40
0834	Painting one priming coat with approved primer over structural steel works in roof structures, columns etc., including preparing the surfaces by thoroughly cleaning oil, grease, dirt and other foreign matters and scoured with wire brushes, fine steel wool scrapers and sand paper, all as per standard specifications.		
A	Zinc Chromate primer	MT	955.35

Item No.	Description	Unit	Rate (Rs.P)
B	Red oxide primer	MT	562.35
0835	Painting (excluding priming coat) on structural steel works in roof structures, columns etc.with synthetic enamel paint of approved brand and shade, brushing to give an even shade including cleaning the surfaces of all dirt, dust and other foreign matters, scaffolding charges etc.complete. All as per standard specifications.		
A	Two coats	MT	1580.50
B	One coat	MT	937.20
0836	Painting (excluding priming coat) on structural steel works in roof structures, columns etc.with aluminium paint of approved brand, brushing to give an even shade including cleaning the surfaces of all dirt, dust and other foreign matters, scaffolding charges etc.complete. All as per standard specifications.		
A	Two coats	M.T	1461.85
B	One coat	M.T	859.35
0837	Providing black board in walls in cement mortar 1:2 mixed with black oxide over rough plastered surfaces in cement mortar 1:4, 12 mm thick and providing 25 mm border around in cement mortar 1:3, neatly rounded etc. complete.	SQM	206.35
	Cement Consumption 13.20 K.G/SQM		
0838	Repairs to plaster of thickness 12 to 20 mm in patches of area 2.5 Sqm and under with cement mortar 1:4 including cutting the patches in proper shape, preparing and plastering the surface of the walls completely including disposal of rubbish within a lead of 50 metre.	SQM	145.35
	Cement Consumption 6.95 K.G/SQM		
0839	Removal of all nails, screws, wooden plugs etc. from the walls, chipping the plastering of small holes caused by removal, cleaning and finishing good the same with cement mortar etc. complete in Quarters.	EACH	107.30
0840	Painting with exterior emulsion paint (ACE or any other equivalent and approved brand) of approved shade on surfaces to give an even shade including preparing the surfaces, removal of dirt, thorough cleaning by watering etc., all as per standard specifications. Rate includes cost of necessary plaster of paris and putty wherever required, labour and all incidentals etc.complete.		
A	Three coats (One coat of Primer of approved brand with two coats of Paint)	SQM	74.80
B	Two coats	SQM	62.05
C	One coat	SQM	39.85

Item No.	Description	Unit	Rate (Rs.P)
0841	Painting with exterior emulsion paint (ACE or any other equivalent and approved brand) of approved shade on STUCCO/EXPOSED AGGREGATE surfaces to give an even shade including preparing the surfaces, removal of dirt, thorough cleaning by watering etc., all as per standard specifications. Rate includes cost of necessary plaster of paris and putty wherever required, labour and all incidentals etc.complete. This is applicable only for STUCCO/EXPOSED AGGREGATE surfaces.		
A	Three coats (One coat of Primer of approved brand with two coats of Paint)	SQM	94.50
B	Two coats	SQM	75.35
C	One coat	SQM	48.70
0842	Painting with Epoxy paint (two or more coats) at all locations, prepared and applied as per manufacturer's specifications including appropriate priming coat, preparation of surfaces etc.complete.		
A	On steel work	SQM	95.15
B	On concrete work	SQM	97.50
0843	Extra charges for plastering to exterior walls of height more than 13.50 metre from plinth level for every additional height of 3 metre or part thereof.	SQM	30.90
0844	Extra charges for plastering to spherical ceiling.	SQM	56.70
0845	Labour charges for painting with primer/plastic emulsion paint/synthetic enamel paint/aluminium paint/anti corrosive bitumastic paint/black board paint/chlorinated rubber paint or any other paint on required surfaces to give an even shade including scraping, cleaning the surfaces of all dirt, dust and other foreign matters, sand papering and stopping, all as per standard specifications. Rate excludes cost of primer and paint. Required primer and paint will be issued by BHEL at stores at free of cost.		
A	For one priming coat with primer	SQM	22.30
B	For three coats (A priming coat & two coats of painting or directly three coats of painting)	SQM	59.45
C	For Two coats of painting	SQM	37.10
D	For one coat of painting	SQM	26.20
0846	Applying two coats of Alltek Superfine (interior plaster) putty to a thickness of 2mm over plastered surface including sand papering and preparing the surface smooth and there after applying one priming coat of Alltek primer and two coats of plastic emulsion paint of approved brand and shade, all as per instructions of Engineer-in-charge.	SQM	289.20

Item No.	Description	Unit	Rate (Rs.P)
IX - ROAD WORKS			
0901	Supply and stacking the following to standard gauge at site of work, all as per instructions of Engineer-in-Charge.		
A	Soling stones 15 cm average thickness (measured in stacks will be reduced by 15 % for payment)	CUM	298.00
B	53 mm IRC size metal (measured in stacks will be reduced by 7.5 % for payment)	CUM	782.55
C	37.50 mm IRC size metal / 37.5 or 40 mm Stone metal ISS (measured in stacks will be reduced by 7.5 % for payment)	CUM	1029.90
D	22.40 mm IRC size metal (No voids)	CUM	1269.45
E	11.20 mm IRC size metal (No voids)	CUM	837.15
F	6 mm IRC size metal (No voids)	CUM	647.95
G	River sand (No voids)	CUM	450.55
H	Gravel / Red earth (No voids)	CUM	240.85
I	Earth (measured in stacks will be reduced by 20 % for payment)	CUM	207.30
J	Cattle manure (measured in stacks will be reduced by 8 % for payment)	CUM	371.75
K	IRC graded stone aggregate of size range from 90 to 45 mm (measured in stacks will be reduced by 7.5 % for payment)	CUM	539.00
L	IRC graded stone aggregate of size range from 63 to 45 mm (measured in stacks will be reduced by 7.5 % for payment)	CUM	680.00
M	IRC graded stone aggregate of size range from 53 to 22.4 mm (measured in stacks will be reduced by 7.5 % for payment)	CUM	930.00
0902	Supply RCC pipes (NP2 Class) of following sizes with collars at site of work, lowering to trench, laying to proper grade and alignment, joining the collars with stiff mixture of cement mortar 1 : 2, testing of joints etc., but excludes cost of cement which will be supplied by BHEL at stores at free of cost.		
A	150 mm dia Cement Consumption - 0.60 KG/ R.M	R.M	333.95
B	250 mm dia Cement Consumption - 0.90 KG/ R.M	R.M	443.20
C	300 mm dia Cement Consumption - 1.10 KG/ R.M	R.M	486.20

Item No.	Description	Unit	Rate (Rs.P)
D	450 mm dia Cement Consumption - 2.40 KG/ R.M	R.M	676.05
E	600 mm dia Cement Consumption - 2.95 KG/ R.M	R.M	1318.05
F	750 mm dia Cement Consumption - 3.90 KG/ R.M	R.M	1602.95
G	900 mm dia Cement Consumption - 4.50 KG/ R.M	R.M	1890.85
H	1200 mm dia Cement Consumption - 6.30 KG/ R.M	R.M	2935.60
0903	Providing of granular sub- base by providing close graded Material, mixing in a mechanical mix plant at OMC, carriage of mixed Material to work site, spreading in uniform layers with motor grader on prepared surface and compacting with vibratory power roller to achieve the desired density,complete as per clause 401of MOHRT-Rev5.		
A	For Grading-V Material (Drainage/ Top Layer)	CUM	1161.65
B	For Grading-III Material (Bottom Layer if thickness more than 300 mm)	CUM	1212.90
0904	Providing and laying 50mm consolidated thick Dense bituminous macadam using 0.24 cum of 26.50-13.20 mm, 0.25 cum of 13.20-2.36 mm and 0.23 cum of 2.36mm & below and with 53.20 kgs of VG 30/VG 40 bitumen for premixing per 10sqm including cost and conveyance of all materials to CMP site, heating the bitumen and aggregate to required temperature and mixing them in required temperature in central hot mix plant 20-30 ton capacity, conveying the mix by tipper trucks to work site, spreading the mix to uniform thickness of 50mm with paver to the specified grades and cross sections and compacted by Vibratory / Pneumatic Roller to the required density etc., including labour for attending tipper trucks, Paver Finisher / 9m paver finisher, Vibratory / Pneumatic rollers and all other tools and plant required, including fuel and all other incidental charges etc., complete as per specification using CMP as per clause 505 MORTH Rev-5.	CUM	10202.20

Item No.	Description	Unit	Rate (Rs.P)
0905	Providing and laying 75mm consolidated thick Dense Bituminous macadam using 0.40 cum of 37.50-13.20mm, 0.35 cum of 13.20-2.36mm and 0.36 cum of 2.36mm & below size IRC metal with 71.30 kgs of VG30/ VG40 bitumen for premixing per 10sqm including cost and conveyance of all materials to CMP site, heating the bitumen and aggregate to required temperature and mixing them in required temperature in central hot mix plant 20-30 ton capacity, conveying the mix by tipper trucks to paver site, spreading the mix to uniform thickness of 75mm with mechanical paver to the specified grades and cross sections and consolidated by 8-10 tonne Vibratory / Pneumatic Roller to the required density etc., including labour for attending to paver to site etc., including hire charges and fuel charges for 20-30 t CMP with bitumen boiler, tipper trucks, Paver Finisher / 9m paver finisher, Vibratory / Pneumatic roller and all other tools and plant required, including fuel and all other incidental charges etc., complete as per specification using CMP as per clause 505 of MORTH rev-5.	CUM	9448.15
0906	Providing and laying 50mm consolidated thick bituminous macadam using 0.20 cum of 26.50-13.20mm, 0.43 cum of 13.20-2.36mm and 0.08 cum of 2.36mm & below size IRC metal with 37 Kgs of VG30/ VG40 bitumen for premixing per 10sqm including cost and conveyance of all materials to CMP site, heating the bitumen and aggregate to required temperature and mixing them in required temperature in central hot mix plant 20-30 ton capacity, conveying the mix by tipper trucks to paver site, spreading the mix to uniform thickness of 50mm with mechanical paver to the specified grades and cross sections and consolidated by 8-10 tonne Vibratory / Pneumatic Roller to the required density etc., including labour for attending to paver to site etc., including hire charges and fuel charges for 20-30 t CMP with bitumen boiler, tipper trucks, Paver Finisher / 9m paver finisher, Vibratory / Pneumatic roller and all other tools and plant required, including fuel and all other incidental charges etc., complete as per specification using CMP as per clause 504 of MORTH Rev-5	CUM	8297.90
0907	Providing and laying 80mm consolidated thick bituminous macadam using 0.64 cum of 37.5 - 13.20mm, 0.44 cum of 13.2 - 2.36mm and 0.13 cum of 2.36mm and below size IRC metal with 62 Kgs of VG30/ VG40 bitumen for premixing per 10sqm including cost and conveyance of all materials to CMP site, heating the bitumen and aggregate to required temperature and mixing them in required temperature in central hot mix plant 20-30 ton capacity, conveying the mix by tipper trucks to paver site, spreading the mix to uniform thickness of 80mm with mechanical paver to the specified grades and cross sections and consolidated by 8-10 tonne Vibratory / Pneumatic Roller to the required density etc., including labour for attending to paver to site etc., including hire charges and fuel charges for 20-30 t CMP with bitumen boiler, tipper trucks, Paver Finisher / 9m paver finisher, Vibratory / Pneumatic roller and all other tools and plant required, including fuel and all other incidental charges etc., complete as per specification using CMP as per clause 504 of MORTH Rev-5.	CUM	8391.65

Item No.	Description	Unit	Rate (Rs.P)
0908	Providing and laying Premix Carpet with Seal Coat Type - A to 20 mm thick using 0.18 cum of 13.20mm, 0.09 cum of 11.20mm and 0.09 cum of 6.70mm with 24.40 kgs of VG30 bitumen for premixing per 10sqm including cost and conveyance of all materials to CMP site, heating the bitumen and aggregate to required temperature and mixing them in required temperature in central hot mix plant 20-30 ton capacity, conveying the mix by tipper trucks to paver site, spreading the mix to uniform thickness of 50mm with mechanical paver to the specified grades and cross sections and consolidated by 8-10 tonne Vibratory / Pneumatic Roller to the required density etc., including labour for attending to paver to site etc., including hire charges and fuel charges for 20-30 t CMP with bitumen boiler, tipper trucks, Paver Finisher / 9m paver finisher, Vibratory / Pneumatic roller and all other tools and plant required, including fuel and all other incidental charges etc., complete as per specification using CMP as per MORTH Rev-5	SQM	241.65
0909	Providing and laying, spreading and compacting graded stone aggregates to Wet Mix Macadam of 250mm thick specification including premixing the materials with water at OMC in mechanical mix plant carriage of mixed material by tipper to site laying in uniform layers with pavers in Sub Base/ Base course on well prepared surface and compacting with vibratory roller to achieve the desired density including cost of material, labour charges, rentals for machinery, fuel and all other incidental charges etc., complete as per clause 406 of MORTH Rev-5	CUM	1487.60
0910	Providing and laying Bituminous Concrete to 40 mm thick using 0.13 cum of 19.00-9.50 mm, 0.17 cum of 9.50-2.36mm and 0.26 cum of 2.36 and below with 50.30 kgs of VG30/ VG40 bitumen for premixing per 10sqm including cost and conveyance of all materials to CMP site, heating the bitumen and aggregate to required temperature and mixing them in required temperature in central hot mix plant 20-30 ton capacity, conveying the mix by tipper trucks to paver site, spreading the mix to uniform thickness of 40mm with mechanical paver to the specified grades and cross sections and consolidated by 8-10 tonne Vibratory / Pneumatic Roller to the required density etc., including labour for attending to paver to site etc., including hire charges and fuel charges for 20-30 t CMP with bitumen boiler, tipper trucks, Paver Finisher / 9 m paver finisher, Vibratory / Pneumatic roller and all other tools and plant required, including fuel and all other incidental charges etc., complete as per specification using CMP as per clause 507 of MORTH Rev-5	CUM	11230.65
0911	Providing laying and rolling of close graded premix carpet of compacted 20mm thickness using 0.0162 cum of 13.20-11.20mm, 0.1404 cum of 11.2-5.6mm, 0.0729 cum of 5.60-2.80 mm, 0.0405 cum of 2.80mm and below (Type B) graded HBG metal using 19kg of VG30 bitumen for 10sqm including premixing at CMP, conveyance by tipper lorry, laying by paver finisher and rolling by Vibratory Roller including cost and conveyance of all materials, hire charges of all T&P all labour charges, fuel and and all other incidental charges etc., Complete as per specification using CMP as per clause 508 of MORTH Rev-5	SQM	200.35

Item No.	Description	Unit	Rate (Rs.P)
0912	Providing and laying, spreading and compacting graded stone aggregates to Crusher Run Macadam specification including premixing the materials with water at OMC in mechanical mix plant carriage of mixed material by tipper to site laying in uniform layers with pavers in Sub Base/ Base course on well prepared surface and compacting with vibratory roller to achieve the desired density including cost of material, labour charges, rentals for machinery, fuel and all other incidental charges etc., complete as per Clause 407 of MORTH Rev-5	CUM	1410.45
0913	Providing and laying Prime Coat over WBM/WMM surface using 7 Kg of Emulsion Bitumen (SS1) per 10 sqm for preparatory to another bituminous construction over it including cost of material, labour charges, rentals for machinery, fuel and all other incidental charges etc., complete as per Clause 502 of MORTH Rev-5	SQM	82.55
0914	Providing and laying Prime Coat over CRM/ Gravel base using 9 Kg of Emulsion Bitumen (SS1) per 10 sqm for preparatory to another bituminous construction over it including cost of material, labour charges, rentals for machinery, fuel and all other incidental charges etc., complete as per Clause 502 of MORTH Rev-5	SQM	100.30
0915	Providing and laying Tack Coat over Dry Lean Cement Concrete surface using 3.00 Kg of Bitumen Emulsion (RS1) per 10 sqm for preparatory to another bituminous construction over it including cost of material, labour charges, rentals for machinery, fuel and all other incidental charges etc., complete as per Clause 503 of MORTH Rev-5	SQM	20.15
0916	Providing and laying Tack Coat over Existing BT surface using 2 Kg of Bitumen Emulsion (RS1) per 10 sqm for preparatory to another bituminous construction over it including cost of material, labour charges, rentals for machinery, fuel and all other incidental charges etc., complete as per Clause 503 of MORTH Rev-5	SQM	19.15
0917	Providing and laying Tack Coat over WBM/ WMM surface (treated with primer) using 2.50 Kg of Bitumen Emulsion (RS1) per 10 sqm for preparatory to another bituminous construction over it including cost of material, labour charges, rentals for machinery, fuel and all other incidental charges etc., complete as per Clause 503 of MORTH Rev-5	SQM	17.35
0918	Providing, laying and compacting Well Gravel including cost and conveyance of the same to work site with an average lead of 5 Km including stacking the same to departmental gauge for premeasurement including all labour charges for laying, spreading etc., complete and directed by the departmental engineers for making up of low berms	CUM	234.10
0919	Providing, laying and compacting Gravel including cost and conveyance of the same to work site with an average lead of 5 Km including stacking the same to departmental gauge for premeasurement including all labour charges for laying, spreading etc., complete and as directed by the departmental engineers for making up of low berms	CUM	333.10

Item No.	Description	Unit	Rate (Rs.P)
0920	Providing and laying Bituminous Concrete to 50 mm thick using 0.22 cum of 26.5- 13.20mm, 0.24 cum of 13.20-2.36mm and 0.26cum of 2.36 & below IRC HBG metal with 62.40 kgs of VG30/ VG40 bitumen for premixing per 10sqm including cost and conveyance of all materials to CMP site, heating the bitumen and aggregate to required temperature and mixing them in required temperature in central hot mix plant 20-30 ton capacity, conveying the mix by tipper trucks to paver site, spreading the mix to uniform thickness of 50mm with mechanical paver to the specified grades and cross sections and consolidated by 8-10 tonne Vibratory / Pneumatic Roller to the required density etc., including labour for attending to paver to site etc., including hire charges and fuel charges for 20-30 t CMP with bitumen boiler, tipper trucks, Paver Finisher / 9m paver finisher, Vibratory / Pneumatic roller and all other tools and plant required, including fuel and all other incidental charges etc., complete as per specification using CMP clause 507 of MORTH.	CUM	10768.20
0921	Formation of embankment with earth from quarrying place and compaction by power roller (100 % compaction)	CUM	539.90
0922	Labour charges for spreading the patchmat material for road patch work. Rate includes preparation of surface, brushing, cleaning, laying patchmat, compacting etc. complete. Patchmat will be supplied by BHEL at stores at free of cost.	SQM	42.00

Item No.	Description	Unit	Rate (Rs.P)
X - DISMANTLING AND DEMOLITION			
1001	Dismantling / removing / demolishing as the case may be of the following by manually/mechanical means and carefully stacking the serviceable materials at site of work or conveying and handing over the same at BHEL stores and disposal of unserviceable materials by transporting and dumping in the near by low level areas within a lead of 100 metres. All as per instructions of Engineer-in-charge.		
A1	Brick work in cement mortar	CUM	530.25
A2	Stone rubble masonry in cement mortar	CUM	632.70
A3	Old plastering / skirting raking out joints / chipping the concrete and roughening the surface.	SQM	14.15
A4	Plain Cement Concrete.	CUM	387.15
A5	RCC works including stacking of steel bars by manual/mechanical means.	CUM	916.95
A6	RCC or PCC (Using jack hammer only for pockets)	CUM	1599.85
A7	Precast concrete or stone slabs in walls, partition walls etc.		
i	Thickness upto 40 mm	SQM	78.00
ii	Thickness above 40 mm upto 75 mm	SQM	116.80
A8	RCC louvers / RCC jally	SQM	152.85
A9	Ellis pattern finish / Insitu mosaic.	SQM	27.95
A10	Tile work in floors and roofs laid in cement mortar.	SQM	27.70
A11	Brick jelly lime concrete	CUM	219.15
A12	Doors / Windows / Ventilators (steel or wood) including frame and shutters, holdfasts, hinges, fastenings etc. of area 3 sqm & below.	EACH	110.15
A13	Only shutters of Doors / Windows / Ventilators (steel or wood) including hinges, fastenings etc.	SQM	20.00
A14	IWC with 'P' trap & foot rests	SET	240.20
A15	EWC (excluding flushing cistern) / Urinal (earthenware) of any size including foot rests / Wash basin with connected fittings / RCC precast sink or other ready made sinks with connected fittings/ Nahani trap.	EACH	144.10
A16	Flushing cistern of any size	EACH	272.45
A17	G.I / PVC pipe lines of various dia including all specials.	R.M	10.80
A18	A.C / C.I rain water pipes upto 150 mm dia with fittings and clamps.	R.M	20.15
A19	S.W pipe lines upto 225 mm dia.	R.M	30.25

Item No.	Description	Unit	Rate (Rs.P)
A20	C.I pipes including earthwork excavation, breaking lead caulked joints, melting of lead and making into blocks, refilling trenches after taking out the pipes etc.		
I	Upto 150 mm dia	R.M	127.60
ii	Above 150 and upto 300 mm dia	R.M	169.60
iii	Above 300 mm dia	R.M	220.10
A21	C.I sluice valve		
I	Upto 150 mm dia	EACH	100.45
ii	Above 150 mm dia	EACH	349.15
A22	A.C sheets from roofs and side cladding including ridges, valleys, gutters etc.	SQM	22.90
A23	G.I / Aluminium sheets / Aluminium Zinc alloy coated sheets from roofs and side cladding including ridges, valleys, gutters etc.	SQM	49.30
A24	Steel structures / steel works in built up sections including bolts, nuts, cutting rivets, welding, dismembering, preparation of DODL etc.	M.T	1549.00
A25	Steel partitions including bolts, nuts, cutting rivets, welding etc. and dismembering	SQM	68.00
A26	North light glasses at various levels ranging from 9 to 24 metre	SQM	77.55
A27	False ceiling / partitions / fixed glazing, all in A.C sheet or hard board or aluminium or gypsum or other materials including connected frame works .	SQM	17.50
A28	Rough stone dry packing for apron, revetments etc.	CUM	219.60
A29	R.C.C fencing post including all earthwork, dismantling base concrete etc.	EACH	87.80
A30	Barbed wire / flexible wire rope in fencing.	K.G	9.45
A31	R.C.C pipes upto 450 mm dia	R.M	183.55
A32	Kerb stone	R.M	17.85
A33	Bituminous road.	CUM	376.20
A34	W.B.M /W.M.M road.	CUM	233.20

Item No.	Description	Unit	Rate (Rs.P)
XI - WATER SUPPLY AND SANITARY ITEMS			
1101	Providing and fixing G.I pipes and specials (B - Class) of approved brand with G.I fittings and clamps on walls & floors, including cutting and making good the walls & floors etc. complete. (Internal work - exposed on walls)		
A	15 mm dia nominal bore.	R.M	147.10
B	20 mm dia nominal bore.	R.M	180.00
C	25 mm dia nominal bore.	R.M	239.65
D	32 mm dia nominal bore.	R.M	290.10
E	40 mm dia nominal bore.	R.M	345.10
F	50 mm dia nominal bore.	R.M	431.55
G	65 mm dia nominal bore.	R.M	531.25
H	80 mm dia nominal bore.	R.M	677.65
I	100 mm dia nominal bore.	R.M	835.65
J	125 mm dia nominal bore.	R.M	1409.55
K	150 mm dia nominal bore.	R.M	1627.45
1102	Making chases upto 7.50 x 7.50 cm in walls for concealed pipe line works etc. including making good to match with existing one after housing pipes etc. complete. Rate excludes cost of pipes.	R.M	57.40
1103	Providing and laying G.I pipes and specials (B - Class) of approved brand with G.I fittings in trenches. (External work) Earth work excavation for trenches and refilling will be paid separately.		
A	15 mm dia nominal bore.	R.M	87.00
B	20 mm dia nominal bore.	R.M	110.60
C	25 mm dia nominal bore.	R.M	162.10
D	32 mm dia nominal bore.	R.M	199.20
E	40 mm dia nominal bore.	R.M	232.70
F	50 mm dia nominal bore.	R.M	290.10
G	65 mm dia nominal bore.	R.M	381.70
H	80 mm dia nominal bore.	R.M	504.25
I	100 mm dia nominal bore.	R.M	650.95

Item No.	Description	Unit	Rate (Rs.P)
J	125 mm dia nominal bore.	R.M	1150.25
K	150 mm dia nominal bore.	R.M	1360.80
1104	Providing and fixing PVC water pipes and specials conforming to ISS on walls and floors with clamps at one metre spacings, joining with proper adhesive as suggested by manufacturers, cutting and making good the wall etc. complete. (internal work - exposed on walls)		
A	PVC Pipe 18/20 mm OD (10 kg/Sq.cm)	R.M	62.90
B	PVC Pipe 25 mm OD (10 kg/Sq.cm)	R.M	80.05
C	PVC Pipe 32 mm OD (10 kg/Sq.cm)	R.M	96.10
D	PVC Pipe 40 mm OD (6 kg/Sq.cm)	R.M	119.65
E	PVC Pipe 50 mm OD (6 kg/Sq.cm)	R.M	156.80
1105	Providing and laying PVC water pipes and specials conforming to ISS in trenches, joining with proper adhesive as suggested by manufacturers etc. complete. (External work) Earth work excavation for trenches and refilling will be paid separately.		
A	PVC Pipe 18/20 mm OD (10 kg/Sq.cm)	R.M	23.35
B	PVC Pipe 25 mm OD (10 kg/Sq.cm)	R.M	32.35
C	PVC Pipe 32 mm OD (10 kg/Sq.cm)	R.M	46.25
D	PVC Pipe 40 mm OD (6 kg/Sq.cm)	R.M	51.10
E	PVC Pipe 50 mm OD (6 kg/Sq.cm)	R.M	72.35
F	PVC Pipe 63 mm OD (6 kg/Sq.cm)	R.M	108.50
G	PVC Pipe 75 mm OD (6 kg/Sq.cm)	R.M	150.70
H	PVC Pipe 90 mm OD (6 kg/Sq.cm)	R.M	211.45
I	PVC Pipe 110 mm OD (6 kg/Sq.cm)	R.M	294.65
J	PVC Pipe 140 mm OD (6 kg/Sq.cm)	R.M	464.30
K	PVC Pipe 160 mm OD (6 kg/Sq.cm)	R.M	594.70
L	PVC Pipe 180 mm OD (6 kg/Sq.cm)	R.M	774.35
M	PVC Pipe 200 mm OD (6 kg/Sq.cm)	R.M	941.90

Item No.	Description	Unit	Rate (Rs.P)
1106	Providing and fixing PVC pipes of 4 K.G / Sqcm conforming to ISS including joining with proper adhesive as suggested by manufacturers and suitable clamps for rain water pipes, drainage etc. Rate excludes all specials like shoe, bend, tee, tee with door etc.		
A	PVC Pipe 75 mm OD	R.M	128.05
B	PVC Pipe 110 mm OD	R.M	225.50
C	PVC Pipe 160 mm OD	R.M	364.85
1107	Providing and fixing PVC moulded fittings / accessories on walls for rain water pipes conforming to IS 13592 Type A including joining with seal rings conforming to IS 5382 and proper adhesive as suggested by manufacturers etc.complete.		
A	75 x75 x 75 mm single tee with door.	EACH	134.50
B	110 x 110 x 110 mm single tee with door.	EACH	197.90
C	160 x 160 x 160 mm single tee with door.	EACH	335.15
D	75 x75 x 75 mm single tee without door.	EACH	119.10
E	110 x110 x 110 mm single tee without door.	EACH	174.80
F	160 x160 x 160 mm single tee without door.	EACH	288.85
G	75 mm shoe	EACH	68.60
H	110 mm shoe	EACH	101.70
I	160 mm shoe	EACH	174.90
J	75 mm bend	EACH	81.90
K	110 mm bend	EACH	150.25
L	160 mm bend	EACH	191.50
1108	Providing and fixing in position of brass wheel valve / gate valve (G.M) of approved brand with C.I wheel etc. complete. (ISI marked)		
A	15 to 25 mm nominal bore	EACH	421.70
B	32 mm nominal bore	EACH	545.35
C	40 mm nominal bore	EACH	712.80
D	50 mm nominal bore	EACH	962.70
E	80 mm nominal bore	EACH	2730.25

Item No.	Description	Unit	Rate (Rs.P)
F	100 mm nominal bore	EACH	4972.00
1109	Providing and fixing in position C.P brass bib cock / stop cock (Medium Duty) of approved brand (ISI marked)		
A	15 mm nominal bore.	EACH	207.55
B	20 mm nominal bore.	EACH	265.25
C	25 mm nominal bore.	EACH	342.10
1110	Providing and fixing in position of following of approved brand (ISI marked)		
A	15 mm nominal bore C.P brass long nose bibcock	EACH	748.70
B	15mm nominal C.P brass stop cock (concealed)	EACH	585.95
C	15 mm nominal C.P brass long body bibcock	EACH	577.10
1111	Providing and fixing in position 15 mm nominal bore C.P brass angle valve for basin mixer and geyser points of approved brand (ISI marked)	EACH	479.85
1112	Providing and fixing in position 100 mm dia C.P brass shower rose (tilting type) of approved brand with 15 or 20 mm dia inlet.	EACH	67.65
1113	Providing and fixing in position of white glazed earthenware wash basin of size 550 x 400 x 225 mm of approved brand with M.S or C.I brackets painted with two coats of synthetic enamel paint, single 15 mm C.P brass pillar tap and C.P brass chain with rubber plug, 32 mm C.P brass waste coupling of standard pattern, 32 mm dia PVC flexible waste pipe etc. complete, including cutting and making good the walls wherever required.	EACH	1605.80
1114	Providing built-in-wash basin of inner dimension 0.30 x 0.25 m with 50 mm thick bottom slab in cement concrete 1:2:4, using 12 to 20 mm size hard broken granite stone jelly and 30 mm thick side walls in cement concrete 1:2:4 using 6 mm granite stone chips applied over chickenmesh and finished with insitu gray mosaic of 10 mm thick wearing layer on both faces. Rate includes cost of all materials, labour, centering, curing and all other incidentals but excluding cost of binding wire and fabrication charges for grills.	R.M	1154.50
1115	Providing and fixing in position of towel rail complete with brackets fixed to wooden cleats with CP brass screws with concealed fitting arrangement of approved quality & colour. (600 mm long towel rail with total length of 645 mm, width 78 mm and effective height of 88 mm, weighing not less than 190 grams)		
A	PTMT towel rail 600 mm	EACH	382.05
B	Brass chromium plated towel rail 600 mm and 20 mm dia	EACH	399.65

Item No.	Description	Unit	Rate (Rs.P)
C	Anodised aluminium Towel rail 60cm long and 20mm dia with brackets	EACH	266.55
1116	Providing and fixing 600 x 450 x 5 mm bevelled edge mirror of superior glass (approved brand) mounted on 5/6 mm thick hard board / ply wood / plastic folder sheet, fixed to wooden cleats with C.P brass screws and washers, etc. complete.		
A	600 x 450 x 5 mm bevelled edge mirror	EACH	374.00
B	Circular shape 450 mm dia Mirror with Plastic moulded frame	EACH	528.00
C	Rectangular shape 453x357 mm Mirror with Plastic moulded frame	EACH	363.00
D	Oval shape 450x350 mm (outer dimensions) Mirror with Plastic	EACH	418.00
E	Rectangular shape 1500x450 mm Mirror with Plastic moulded frame	EACH	803.00
1117	Providing and fixing in position of 600 x 120 x 5 mm glass shelf (approved brand) with edges rounded off, supported on anodised aluminium angle frame with C.P brackets fixed with screws , rawl plugs etc. complete.	EACH	308.00
1118	Providing and fixing RCC precast sink of size 60 x 45 x 25 cm in cement concrete of mix 1:2:4 for 25 mm thick bottom slab and 20 mm thick side walls using 6 mm granite stone jelly, applied on chickenmesh and plastered both sides with cement mortar 1:4, 12 mm thick and finished smooth, supply and fixing PVC waste pipe 32 mm dia. with necessary coupling. etc., complete. Rate includes cost of all materials, labour, curing, carrying and fixing in position etc. but excluding cost of binding wire and fabrication charges for grills, all as per standard specifications.	EACH	1244.40
1119	Providing and fixing in position of ready made sink including PVC flexible waste pipe of 32 mm dia with necessary C.P waste coupling etc. complete.		
A	Cudappa sink of size 600X450X200 or thereabouts (outer dimensions) - 12 mm thick.	EACH	766.10
B	Cudappa sink of size 600X600X200 or thereabouts (outer dimensions) - 12 mm thick.	EACH	932.15
C	Marble (white) sink of size 23" x 17" x 9"/10" or thereabouts (outer dimensions) - 12 mm thick.	EACH	1174.80
D	Marble (white) sink of size 23" x 23" x 9"/10" or thereabouts (outer dimensions) - 12 mm thick.	EACH	1460.80
E	Granite (black) sink of size 23" x 17" x 9"/10" or thereabouts (outer dimensions) - 12 mm thick.	EACH	1614.80

Item No.	Description	Unit	Rate (Rs.P)
F	Granite (black) sink of size 23" x 23" x 9"/10" or thereabouts (outer dimensions) - 12 mm thick.	EACH	1900.80
1120	Conveying RCC/ ready made sink from BHEL stores to site of work and fixing in proper position with cement mortar including supply and fixing 32 mm dia PVC waste pipe with necessary coupling etc. complete. Rate excludes cost of sink which will be supplied by BHEL at stores at free of cost.	EACH	181.50
1121	Providing and fixing in position of 100 x 75 mm Nahani trap with PVC grating, all as per standard specifications.	EACH	182.70
1122	Providing and fixing in position of 150 mm SW gully trap with HCl grating, all as per standard specifications.	EACH	288.75
1123	Providing and fixing in position of brass ball valve of approved brand with plastic float fitted with brass rod etc. complete.		
A	20mm nominal bore	EACH	385.80
B	25mm nominal bore	EACH	432.30
1124	Providing and fixing in position of Indian type white glazed earthenware water closet pan of approved brand with suitable P or S trap including a pair of white glazed foot rest etc. complete.		
A	580 mm size	EACH	1112.35
B	500 mm size	EACH	1579.85
1125	Providing and fixing in position of orissa pattern water closet of approved brand with integral type foot rests,suitable P or S trap etc. complete.		
A	580 mm size (White) (Parryware/Neycer/Cera)	EACH	1815.25
B	580 mm size (colour)	EACH	2146.35
1126	Providing and fixing in position of 25 mm nominal bore C.P half turn flush valve of approved brand (ISI marked) in pipe lines.	EACH	1017.50
1127	Providing and fixing in position of pedestal type water closet (European type W.C pan) 400 mm high of approved brand with seat and lid, C.P brass hinges and rubber buffers, 10 litre PVC low level flushing cistern with fittings and painted C.I / M.S brackets with 15 mm PVC connection, 32/40 mm PVC flush bend with fittings and clamps, over flow arrangement with specials and mosquito proof coupling including painting of fittings & brackets, cutting and making good the walls and floors wherever required etc. complete.		
A	White glazed (white seat and lid)	EACH	4530.05
B	Colour glazed with colour seat and lid	EACH	4931.55

Item No.	Description	Unit	Rate (Rs.P)
1128	Providing and fixing in position of 10 litre low level PVC flushing cistern of approved make with fittings and flush pipe etc. complete.	EACH	679.95
1129	Providing and fixing in position 32 mm dia G.I flush pipe with brass union for high level flushing cistern including cutting and making good the walls and floors etc. complete.	EACH	543.95
1130	Providing and fixing in position of white glazed earthenware urinal of approved brand with teakwood plugs and screws/clamps, including standard PVC flush pipe and C.P. brass spreaders with brass unions and G.I clamps complete, cutting of floor and walls and making good all damages and finishing to match with the existing work etc., complete.		
A	Flat back angular lipped urinal of 430 x 260 x 350 mm or 340 x 410 x 265 mm	EACH	1383.50
B	Flat back half stall urinal of size 580x380x350 mm	EACH	2606.70
1131	Providing, laying in proper grade and alignment and joining glazed stoneware pipes of approved brand with stiff mixture of cement mortar 1:1 and spun yarn including testing of joints etc.complete.		
A	100 mm dia S.W Pipes Cement consumption 0.64 Kg / R.M	R.M	176.75
B	150 mm dia S.W Pipes Cement consumption 1.20 Kg / R.M	R.M	270.45
C	200 mm dia S.W Pipes Cement consumption 1.77 Kg / R.M	R.M	402.65
D	225 mm dia S.W Pipes Cement consumption 2.17 Kg / R.M	R.M	491.75
1132	Providing rectangular/circular manhole as per Drawing for the following depths. Rate includes earth work excavation in all soils (except hard rock requiring blasting) including soft disintegrated rock, watering and ramming of foundation bed, providing cement concrete 1:4:8 in foundation, including necessary slope and forming channels smoothly finished in C.M 1:2, brick work in C.M 1:5 for arch ring, etc., using standard approved bricks, plastering in cement mortar 1:4 for side walls (outside and inside), cement concrete 1:2:4 using 12 to 20 mm HBGS jelly for manhole cover fixing, providing and fixing C.I steps for ladder rungs, etc., complete. Rate includes an initial lead of 10 m and all lifts for excavation and other charges etc., complete, but excludes cost of manhole cover and frame.		
A	Upto 0.90 m depth (Rectangular) Cement consumption 128.00 Kg / Each	EACH	4131.75
B	Above 0.90 and upto 1.20 m depth (Rectangular) Cement consumption 278.01 Kg / Each	EACH	6589.65

Item No.	Description	Unit	Rate (Rs.P)
C	Above 1.20 and upto 1.50 m depth (Rectangular) Cement consumption 320.31 Kg / Each	EACH	8361.35
D	Above 1.50 and upto 1.80 m depth (Rectangular) Cement consumption 332.10 Kg / Each	EACH	9284.90
E	Above 1.80 and upto 2.10 m depth (Rectangular) Cement consumption 367.94 Kg / Each	EACH	10773.80
F	Above 2.10 and upto 2.40 m depth (Rectangular) Cement consumption 403.63 Kg / Each	EACH	12463.50
G	Above 2.40 and upto 2.70 m depth (Rectangular) Cement consumption 594.62 Kg / Each	EACH	15600.85
H	Above 2.70 and upto 3.00 m depth (Rectangular) Cement consumption 618.57 Kg / Each	EACH	16756.65
I	Above 3.00 and upto 3.30 m depth (Rectangular) Cement consumption 654.69 Kg / Each	EACH	18619.60
J	Above 3.30 and upto 3.60 m depth (Rectangular) Cement consumption 690.82 Kg / Each	EACH	20482.55
1133	Supply and fixing C.I cover with/without frame for manholes/gully traps.		
A	500 mm dia C.I cover only (Without frame) (Medium duty) Weight of the cover to be not less than 58 K.G.	EACH	2587.35
B	500 mm dia C.I cover with frame (Medium duty) Total weight of cover and frame to be not less than 116 K.G (Weight of cover 58 K.G and weight of frame 58 K.G)	EACH	5309.70
C	560 mm dia C.I cover only. (Without frame) (Heavy duty) Weight of cover to be not less than 108 K.G.	EACH	5562.35
D	560 mm dia C.I cover with frame. (Heavy duty) Total weight of cover and frame to be not less than 208 K.G (Weight of cover 108 K.G and weight of frame 100 K.G)	EACH	10045.20
E	300 x 300 mm C.I cover without frame for gully trap (standard pattern) The weight of cover to be not less than 4.50 K.G.	EACH	260.60
1134	Labour charges for laying centrifugally C.I pipes (S&S or flanged pipes) in trenches to proper grade and alignment. Rate excludes cost of pipes.	M.T	1020.45
1135	Labour charges for laying C.I specials such as tees, bends, collars, tapers, caps etc. in trenches to proper alignment. Rate excludes cost of specials.	M.T	1960.45

Item No.	Description	Unit	Rate (Rs.P)
1136	Labour charges for cutting C.I pipes true to axis and filing smoothly and finishing the ends complete.		
A	80 mm dia C.I pipe.	EACH	44.65
B	100 mm dia C.I pipe.	EACH	60.10
C	125 mm dia C.I pipe.	EACH	83.90
D	150 mm dia C.I pipe.	EACH	113.10
E	200 mm dia C.I pipe.	EACH	150.85
F	250 mm dia C.I pipe.	EACH	186.95
G	300 mm dia C.I pipe.	EACH	224.70
H	350 mm dia C.I pipe.	EACH	260.80
I	400 mm dia C.I pipe.	EACH	298.30
J	450 mm dia C.I pipe.	EACH	334.65
1137	Providing lead caulked joints to C.I pipes and specials including testing of joints but excluding cost of pig lead.		
A	80 / 100 mm dia pipe.	EACH	163.50
B	125 / 150 mm dia pipe.	EACH	241.50
C	200 / 250 mm dia pipe.	EACH	365.95
D	300 / 350 mm dia pipe.	EACH	498.25
E	400 / 450 mm dia pipe.	EACH	698.95
1138	Providing flanged joints to double flanged C.I pipes and specials including testing of joints, 3 mm thick rubber insertions, suitable bolts and nuts etc. complete.		
A	100 / 125 mm dia pipe.	EACH	173.25
B	150 / 200 mm dia pipe.	EACH	208.55
C	250 / 300 mm dia pipe.	EACH	323.45
D	350 / 400 mm dia pipe.	EACH	453.75
E	450 / 500 mm dia pipe.	EACH	836.75

Item No.	Description	Unit	Rate (Rs.P)
1139	Desludging and cleaning the underground equalising reservoirs by dewatering, scraping the silt deposited on floor, brushing, swabbing, cleaning, scraping side walls and floors with bleaching powder, removing dirt, moss, cleaning the reservoirs with fresh water etc. complete. Rate includes labour, scaffolding, brushes, brooms etc. complete. Bleaching powder, electrical/diesel operated pumps with power/diesel and fresh water will be supplied by BHEL at free of charges.	SQM	6.00
1140	Cleaning the main over head water tanks by dewatering, scouring the silt deposited on the floor of tanks, removing cobweb, brushing, scraping the side walls and floors of inner and outer compartments using cleaning powder, removal of sediment, applying cleaning powder on all interior surfaces and kept under disinfection for a minimum of 12 hour, then washing thoroughly with clean water without any residual cleaning powder or any foreign matter etc. complete. Rate includes all labour, brushes, brooms etc. Cleaning powder will be supplied by BHEL at stores at free of cost. Payment will be made for the floors and inside walls of the water tanks. (Staging height may vary from 15 to 23 M from ground level)	SQM	6.50
1141	Cleaning of over head water tank of 500 cum capacity with a staging height of 23 to 40 M from ground level by de-watering, removing algae, fungus, scouring the silt deposited on the floors of the tank, removing cobweb, brushing, scraping the side walls of inner and outer shells, floors, columns and beams using necessary cleaning powder on all interior surfaces and kept under disinfection for a minimum of 12 hour, then washing thoroughly with clean water without any residual cleaning powder or any other foreign matter etc., complete. Necessary cleaning powder, brushes, brooms and ladder will be supplied by BHEL at stores at free of cost. Contractor has to take all safety precautions.	EACH	4880.75
1142	Replacement to the damaged water closet by providing new Orissa water closet pan of approved brand with suitable trap. Rate includes dismantling the damaged water closet with foot rests, trap, ellis/mosaic floor finish with base concrete, sand and refilling with fresh river sand, providing new Orissa pan with trap & fixing in position, providing 20 mm thick ellis pattern finish over 75 mm thick floor concrete in PCC 1:5:10 using 40 mm size stone jelly for that area, finishing the side walls to match with the existing one etc. complete.		
A	580 mm size (White)	EACH	1617.90
B	580 mm size (White), but with 20 mm thick insitu mosaic floor finish as per usual practice instead of ellis pattern finish.	EACH	1788.40
1143	Replacement to the damaged European water closet by providing new white glazed European water closet (white) 400 mm high of approved brand with seat & lid. Rate includes dismantling the damaged water closet, providing new EWC, fixing, all labour etc. complete.	EACH	1495.60

Item No.	Description	Unit	Rate (Rs.P)
1144	Labour charges for dismantling the trap alone without damaging the water closet & refixing with new trap supplied by BHEL at stores at free of cost & making good all damages and finishing to match with the existing one etc.complete.	EACH	211.75
1145	Replacement to the damaged nahani trap by providing and fixing in position of new PVC nahani trap 100 x 75 mm with grating as per standard specifications. Rate includes labour for dismantling the existing trap, refixing with new one, making good all damages and finishing to match with the existing one etc., complete.	EACH	352.00
1146	Providing 32 mm dia PVC waste pipe to sink with necessary coupling etc complete.	EACH	49.50
1147	Cleaning & complete removal of all the obstructions/blockage accumulated such as silt, sand, debris, all other wastes etc. from manhole & disposing the same in the near by low level areas. Scope includes opening the manhole cover, removing all the blockage such as silt, sand, debris, all other wastes etc., lifting, disposing the same in the near by low level areas, all labour, tools, repositioning the manhole cover after finishing the job etc.complete.		
A	Manhole upto 1.50 metre depth	EACH	168.50
B	Manhole beyond 1.50 but upto 3.30 metre depth	EACH	378.40
1148	Cleaning the sewer line in all depths between manhole to manhole & complete removal of all the obstructions/blockage accumulated such as silt, sand, debris, all other wastes etc. by means of blockage removal machine attached with sewer cleaning rod etc. & disposing the same in the near by low level areas. Scope includes opening the manhole cover, removing all the blockage such as silt, sand, debris, all other wastes etc., lifting, disposing the same in the near by low level areas, all labour, tools, repositioning the manhole cover after finishing the job etc.complete. Blockage removal machine attached with sewer cleaning rod for the job will be issued by BHEL at stores at free of cost.	R.M	16.80
1149	Labour charges for conveying, laying and fixing G.I pipes and specials with G.I fittings and clamps on walls & floors, including cutting and making good the walls & floors etc. complete. Rate includes cost of white lead, hemp, oil, sand etc. but excludes cost of G.I pipes, specials and clamps which will be supplied by BHEL at stores at free of cost.		
A	15 mm dia nominal bore.	R.M	58.55
B	20 mm dia nominal bore.	R.M	64.85
C	25 mm dia nominal bore.	R.M	71.40
D	32 mm dia nominal bore.	R.M	80.05
E	40 mm dia nominal bore.	R.M	102.15
F	50 mm dia nominal bore.	R.M	124.10

Item No.	Description	Unit	Rate (Rs.P)
G	65 mm dia nominal bore.	R.M	135.20
H	80 mm dia nominal bore.	R.M	143.70
I	100 mm dia nominal bore.	R.M	229.75
J	125 mm dia nominal bore.	R.M	163.35
K	150 mm dia nominal bore.	R.M	172.40
1150	Painting G.I pipes and fittings with synthetic enamel paint of two coats over a ready mixed priming coat, both of approved quality for new work.		
A	15 mm diameter pipe	R.M	8.45
B	20 mm diameter pipe	R.M	9.95
C	25 mm diameter pipe	R.M	13.10
D	32 mm diameter pipe	R.M	15.50
E	40 mm diameter pipe	R.M	18.40
F	50 mm diameter pipe	R.M	21.70
1151	Conveying polyethylene cylindrical moulded water storage tank of following capacity from BHEL stores to site of work and placing it in proper position in buildings at required levels/floors. All as per instructions of Engineer in charge. Rate includes conveyance, placing it in position at required level, fixing the specials like barrel nipples etc. complete. PVC tank and all specials will be issued by BHEL at stores at free of cost.		
A	Up to 500 litre	EACH	99.00
B	Above 500 but up to 1000 litre	EACH	123.20
C	Above 1000 but up to 2000 litre	EACH	198.00
1152	Labour charges for conveying, laying and fixing G.I pipes and specials (B - Class) of approved brand with G.I fittings in trenches. Rate includes cost of white lead, hemp, oil, sand etc. but excludes cost of G.I pipes, specials and clamps which will be supplied by BHEL at stores at free of cost.		
A	15 mm dia nominal bore.	R.M	8.45
B	20 mm dia nominal bore.	R.M	8.45
C	25 mm dia nominal bore.	R.M	12.90
D	32 mm dia nominal bore.	R.M	12.95
E	40 mm dia nominal bore.	R.M	17.25
F	50 mm dia nominal bore.	R.M	17.45

Item No.	Description	Unit	Rate (Rs.P)
G	65 mm dia nominal bore.	R.M	30.55
H	80 mm dia nominal bore.	R.M	30.75
I	100 mm dia nominal bore.	R.M	45.10
J	125 mm dia nominal bore.	R.M	45.10
K	150 mm dia nominal bore.	R.M	70.50
1153	Providing and fixing gun metal non- return valve of approved quality(screwed end)		
A	25 mm nominal bore (Horizontal)	EACH	388.30
B	25 mm nominal bore (Vertical)	EACH	421.30
C	32 mm nominal bore (Horizontal)	EACH	522.70
D	32 mm nominal bore (Vertical)	EACH	599.70
E	40 mm nominal bore (Horizontal)	EACH	646.15
F	40 mm nominal bore (Vertical)	EACH	855.15
G	50 mm nominal bore (Horizontal)	EACH	934.80
H	50 mm nominal bore (Vertical)	EACH	1143.80
I	65 mm nominal bore (Horizontal)	EACH	1674.25
J	65 mm nominal bore (Vertical)	EACH	1916.25
K	80 mm nominal bore (Horizontal)	EACH	2369.90
L	80 mm nominal bore (Vertical)	EACH	3216.90
1154	Supply at site of work and fixing in position of 32mm dia. CP bottle trap for water line connection in wash basin / urinals of approved brand and quality. All as per standard specifications and instructions of Engineer-in-charge.	EACH	625.75
1155	Supplying and placing in proper position of Polyethylene cylindrical moulded vertical storage tank of 500 litres capacity of approved quality in buildings at required levels / floors as per the instruction of Engineer in charge. Rate shall include cost of the tank, taxes, duties, loading unloading transportation charges delivery to BHEL conveying to site of work and placing in position at required level, fixing the barrel nipple to the tank etc., and all other incidental charges etc., complete. Rate will exclude the cost of all special like barrel nipple etc., which will be issued by BHEL at free of cost	EACH	3759.30

Item No.	Description	Unit	Rate (Rs.P)
1156	Providing and fixing in position of fire clay laboratory sink (white) of size 610 mm x 460 mm x 205 mm or thereabouts of approved make and quality Neycer or equivalent with 32 mm waste coupling, waste hose and 250 mm clamps with necessary fixing arrangements. Rate includes cost of sink, waste coupling, waste hose, clamps, labour for fixing and all other incidental charges etc., complete. All as per standard specifications and instructions of Engineer in charge.	EACH	9211.70
1157	Providing and fixing in position of white glazed earthen ware wash hand basin of oval shape size 540 mm x 460 mm or thereabouts of approved make and quality (Parry ware or equivalent) with 32 mm CP Waste coupling and necessary fixing arrangements. Rate includes cost of wash basin, waste coupling, labour for fixing and all other incidental charges, etc., complete. All as per standard specifications and instructions of Engineer in charge	EACH	2066.00
1158	Providing and fixing in position of Float valve- PTMT (Poly Tetra- Methylene Terephthalate) Ball Cock-20 mm nominal bore of PRAYAG (India) make with Epoxy coated Aluminium rod and HD Ball etc. complete(Full Set)	EACH	302.00
1159	Labour charges for removing the blockage in the gully trap and cleaning it completely, all as per the instructions of Engineer-in-charge.	No	32.25

Item No.	Description	Unit	Rate (Rs.P)
XII - ALUMINIUM WORKS, FALSE CEILING ETC.			
1201	Providing and fixing anodised aluminium work for doors, windows, ventilators and partitions with extruded built up standard tubular sections / appropriate Z sections of approved make conforming to IS:733 & 1285, fixed with rawl plugs & screws or with fixing clips, or with expansion hold fasteners including necessary filling up of gaps at junctions, at top, bottom and sides with required PVC / neoprene felt etc. Aluminium sections shall be smooth, rust free, straight, mitred and joined mechanically wherever required including cleat angle, aluminium snap beading for glazing / panelling, C.P brass / stainless steel screws, all complete as per architectural drawings and instructions of Engineer-in-charge. (Glazing and panelling to be paid for separately)		
A	For fixed portion - Anodised aluminium (anodised transparent or dyed to required shade according to IS 1868, minimum anodic coating of grade AC 15)	K.G	302.20
B	For shutters of doors, windows and ventilators including providing and fixing hinges / pivots and making provision for fixing of fittings wherever required including cost of PVC/ neoprene gasket required. (Fittings shall be paid for separately). Anodised aluminium (anodised transparent or dyed to required shade according to IS 1868, minimum anodic coating of grade AC 15)	K.G	324.40
1202	Extra for powder coated aluminium (minimum thickness of powder coating 50 micron) sections instead of anodised aluminium sections.	K.G	26.40
1203	Extra for polyester powder coated aluminium (minimum thickness of polyester powder coating 50 micron) sections instead of anodised aluminium sections.	K.G	33.00
1204	Providing and fixing glazing in aluminium door, window, ventilator shutters and partitions etc. with PVC/ neoprene gasket etc. complete as per drawing and instructions of Engineer-in-charge. (Cost of aluminium snap beading shall be paid in basic item.)		
A	With float glass panes of 4 mm thick	SQM	797.60
B	With float glass panes of 5.50 mm thick	SQM	948.40
1205	Providing and fixing double action hydraulic floor spring with stainless steel cover plate of approved brand and manufacture conforming to IS : 6315 for doors including cost of cutting floors as required, embedding in floors and cover plates with brass pivot and single piece M.S sheet outer box with side plate etc. complete as per instructions of Engineer-in-charge.	EACH	1904.05

Item No.	Description	Unit	Rate (Rs.P)
1206	Providing and fixing powder coated aluminium work (minimum thickness of powder coating 50 micron) consisting of tee / angle sections of approved make conforming to IS:733 in frames of false ceiling including aluminium angle cleats with necessary C.P brass / stainless steel sunk screws, aluminium perimeter angles fixed to wall with rawl plugs at 450 mm c/c and fixing the frame work to level adjusting hangers (6mm dia MS rods) with necessary cadmium plated machine screws, all complete as per drawing and directions of Engineer-in-charge.(Level adjusting hangers, ceiling cleats and expansion hold fasteners to be paid for separately)	K.G	451.90
1207	Providing and fixing 6 mm dia G.I level adjusting hangers (upto 1200 mm length) fixed to roof slabs by means of ceiling cleats made of G.I flat 40 x 3 mm size, 60 mm long and expansion hold fasteners 12.5 mm dia, 40 mm long etc.complete.	EACH	99.90
1208	Providing and fixing machine moulded anodised aluminium (anodised transparent or dyed to required shade according to IS 1868, minimum anodic coating of grade AC 15) sheet covering of approved pattern and design made out machine cut aluminium sheet and machine holed for receiving screws, over expansion joints on vertical surfaces / ceilings with full threaded cadmium plated steel screws 4 mm dia, stem 30 mm long and aluminium washers 2 mm thick, 15 mm dia at a staggered pitch of 200 mm c/c including drilling holes in the receiving surface and providing expandable plastic sleeves in holes etc. complete.	K.G	400.20
1209	Providing false ceiling at all height with 12.5 mm thick tapered edge gypsum board conforming to IS : 2095 including providing and fixing of frame work made of special sections of power pressed from M.S sheet and galvanised in accordance of zinc coating of grade 350 as per IS:277 and consisting of angle cleats of size 25 wide & 1.6 mm thick with flanges of 22 mm and 37 mm at 1200 mm c/c one flange fixed to the ceiling with dash fastener 12.5 mm dia, 40 mm long with 6 mm dia bolts to the angle hangers of 25 x 25 x 0.55 mm of required length and other end of angle hanger being fixed with nut and bolts to G.I channels 45 x 15 x 0.9 mm running at the rate of 1200 mm c/c to which the ceiling section 0.5 mm thick bottom wedge of 80 mm with tapered flanges of 26 mm each having clips of 10.5 mm at 450 mm c/c shall be fixed in a direction perpendicular to G.I channel with connecting clips made of 2.64 mm dia, 230 mm long G.I wire at every junction including fixing the gypsum board with ceiling section and perimeter channels 0.5 mm thick 27 mm high having flanges of 20 mm and 30 mm long, the perimeter of ceiling fixed to wall / partition with the help of rawl plugs at 450 mm c/c with 25 mm long drive all screws @ 230 mm interval including joining and fixing to a flush finish of tapered and square edges of gypsum board with recommended filler, paper tapes, finisher and two coats of primer suitable for gypsum board as per manufacturers' specification and also including the cost of making openings for light fittings, grills, diffusers, cutouts made with frame of perimeter channels suitably fixed all complete as per drawing, specification and direction of Engineer-in-charge, but excluding the cost of painting.	SQM	740.65

Item No.	Description	Unit	Rate (Rs.P)
1210	Providing false ceiling at all heights using the following ceiling tiles. The scope of work includes providing and fixing frame of grid size 600 mm x 600 mm or thereabouts using GI sections of main tees of size 24mm x 38mm x, cross tees of size 24mm x 38mm, wall angles of size 19mm x 19mm, suspended by hangers of ceiling/ stay angles / G I wires of 2mm x 2 ply of 8' length screwed with suitable bullets of size 45 to 50mmx 8mm size to RCC roof ceiling / steel trusses etc. complete. hangers and height adjustment clips if any shall also to be provided wherever light fixtures / AC grills / diffusers are flush to the ceiling frame work and the ceiling boards have to made alright accordingly. Rate to include cost of all materials involved including suitable fasteners, screws, etc., , labour charges and all other incidentals etc., Complete. All as per standard / manufacturers specifications and instructions of Engineer-in- charge.		
a	Arm Gyp- FB Ceiling tiles of Armstrong make of size 595mm x 595mm x 9mm thick	SQM	1246.05
b	Aruba- FB Ceiling tiles of Armstrong make of size 595mm x 595mm x7.5mm thick	SQM	1137.60
1211	Providing 10 mm thick plaster of paris (Gypsum anhydrous) ceiling upto a height of 5 metre above floor level over first clas kail wood strips 25 x 6 mm with 10 mm gap in between and reinforced with rabbit wire mesh fixed to wooden. (Frame work will be paid separately)		
A	Flat surfaces	SQM	715.50
B	Curved surfaces	SQM	826.10
1212	Extra for any sunk or raised mouldings in the plaster of paris (Gypsum anhydrous) ceiling.	SQM	207.60
1213	Extra for providing plaster of paris (Gypsum anhydrous) ceiling for every 1 m height above 5 metre height from floor level. (Height beyond 5 metre to be measured for extra payment)	SQM	84.05
1214	Providing and fixing 100 mm brass lock (mortise latch & lock with six levers) for aluminium doors including necessary cutting and making good etc.complete.	EACH	371.40
1215	Providing and fixing anodised (AC 15) aluminium round shape handle of outer dia 100 mm with SS screws etc.complete, all as per instructions of Engineer in charge.	EACH	58.60
1216	Providing and fixing powder coated (50 micron) aluminium round shape handle of outer dia 100 mm with SS screws etc.complete, all as per instructions of Engineer in charge.	EACH	64.10
1217	Providing and fixing polyester powder coated (50 micron) aluminium round shape handle of outer dia 100 mm with SS screws etc.complete, all as per instructions of Engineer in charge.	EACH	69.60

Item No.	Description	Unit	Rate (Rs.P)
1218	Servicing / overhauling, oiling, cleaning of aluminium door / window shutter of any size for smooth operation as per instructions of Engineer-in-charge. Rate includes cost of tool and labour (Excluding cost of spares which will be paid separately) and other incidental charges etc. complete	SQM	179.50
1219	Providing Powder coated aluminium alloy grills of following and fixing in proper position in windows/ventilators/balconies/partitions/fences/racks etc. with necessary appropriate type, material, brand & quality screws as per manufacturers recommendation etc.complete, all as per the instructions of Engineer-in-charge.		
A	Aluminium Grill 12x4-4" open -7.5 mm thk (245-255g/sqft)	SQM	1922.40
B	Aluminium Grill 12x4-4" open -6.3 mm thk 175-185g/sqft	SQM	1637.75
C	Aluminium Grill 12x4-4" open -5.5 mm thk 125-135g/sqft	SQM	1495.40
D	Aluminium Grill 12x4-3" open -7.5 mm thk 315-325g/sqft	SQM	2207.15
E	Aluminium Grill 12x4-3" open -6.3 mm thk 230-240g/sqft	SQM	1993.60
F	Aluminium Grill 12x4-3" open -5.5 mm thk 160-170g/sqft	SQM	1708.90
G	Aluminium Grill 12x4-2" open -7.5 mm thk 410-420 g/sqft	SQM	2420.70
H	Aluminium Grill 12x4-2" open -5.5 mm thk 200-210g/sqft	SQM	2207.15
1220	Manufacturing, supplying and fixing in position of partitions for an approximate height of 3.20 m as detailed below: The bottom 90 cm and top 110 cm of the partition shall be of wooden, using 9 mm thick interior grade ISI marked (IS : 12823) three layered melamine faced prelaminate (both side) particle board of approved shade with Powder coated aluminium frame work. The middle 120 cm height of partition shall be of glazed using 5 mm thick plain glass and powder coated aluminium frame work of approved quality. The partitions shall be rigidly fixed on floors and walls using 8 mm anchor fasteners including cutting and making good the walls and floors etc., complete. FRAME WORK: The frame work shall be with Powder coated aluminium sections with suitable aluminium beadings and rubber gaskets. The bottom member shall be of size 3 ¾" x 1 ¾" and 1.70 mm thick (weight 1.312 kg/m). The middle, top and vertical members shall be of size 2 ½" x 1 ½" and 1.28 mm thick (weight 0.754 kg/m). The verticals shall be generally spaced at 0.90 m centers and can be suitably varied at corners, wall junctions etc, without affecting the general elevation. Generally all the vertical sections shall be taken up to ceiling height and fixing the same with RC beams/slabs for better rigidity. Rate includes cost of all materials, labour and other incidentals etc., complete.	SQM	2365.85

Item No.	Description	Unit	Rate (Rs.P)
1221	<p>Manufacturing, supplying and fixing in position of partitions for an approximate height of 3.20 m as detailed below: The bottom ,middle and top of the partition (full portion) shall be of wooden, using 9 mm thick interior grade ISI marked (IS : 12823) three layered melamine faced prelaminate (both side) particle board of approved shade with Powder coated aluminium frame work. FRAME WORK: The frame work shall be with Powder coated aluminium sections with suitable aluminium beadings and rubber gaskets. The bottom member shall be of size 3 3/4" x 1 3/4" and 1.70 mm thick (weight 1.312 kg/m). The middle, top and vertical members shall be of size 2 1/2" x 1 1/2" and 1.28 mm thick (weight 0.754 kg/m). The verticals shall be generally spaced at 0.90 m centers and can be suitably varied at corners, wall junctions etc, without affecting the general elevation. Generally all the vertical sections shall be taken up to ceiling height and fixing the same with RC beams/slabs for better rigidity. Rate includes cost of all materials, labour and other incidentals etc., complete.</p>	SQM	2385.00
1222	<p>Manufacturing, supplying and fixing in position of Aluminium partitions for an approximate height of 1.50m as detailed below: The bottom 90 cm of the partition shall be of wooden, using 9 mm thick interior grade ISI marked (IS:12823) three layered melamine faced prelaminate (both side) particle board of approved shade with Powder coated aluminium frame work. The top 0.60 m height of partition shall be of glazed using 5 mm thick frosted glass and anodized aluminium frame work of approved quality. The partitions shall be rigidly fixed on floors and walls using metal fasteners including cutting and making good the walls and floors etc. complete. The frame work shall be with Powder aluminium sections with suitable aluminium beadings and rubber gaskets. The bottom member shall be of size 3 3/4" x 1 3/4" and 1.70 mm thick (1.312 kg/m) approximate. The middle, top and vertical members shall be of size 2 1/2" x 1 1/2" and 1.28 mm thick (0.754 kg/m) approximate and the verticals shall be generally spaced at 0.90 m centers and can be suitably varied at corners, wall junctions etc, without affecting the general elevation. Rate includes cost of all materials, labour and other incidentals etc., complete</p>	SQM	3313.55

Item No.	Description	Unit	Rate (Rs.P)
1223	<p>Manufacturing, supplying and fixing in position of Powder coated aluminium single leaved/double leaved glazed door of overall size 1.00 x 2.10m with suitable frame work as per the following specification and instructions of Engineer- in- charge.</p> <p>The alround vertical and horizontal outer frame shall be with 4" x 1¾" x 1.60 mm (unit wt. 1.312 kg/m)sections and for door shutter the bottom member shall be with 3 ¾" x 1 ¾" x 1.70 mm thick (unit wt. 1.312 kg/m) shutter top and verticals shall be of size 1 ¾" x 1 ¾" x 1.52 mm thick (unit wt. 0.885 kg/m) and shutter divider shall be 2 nos of of 1 ¾" x 1 ¾" x 1.70 mm thick (unit wt. 0.885 kg/m) with necessary beadings and rubber gaskets as per standard specifications. The upper panel of 120 cm shall be with 5 mm thick plain glass and lower panel of 90cm shall be with 9 mm thick interior grade ISI marked (IS:12823) three layered melamine faced prelaminate (both side) particle board . Door shall be provided with 2 Nos. of 300 mm long anodized aluminium handle, One No. of ISI marked heavy duty door closer of approved brand, One No. 200 mm long anodized aluminium tower bolt, suitable lock (4 lever), required top and bottom pivots, all as per specification of Engineer in charge. Rate includes cost of all materials, labour and other incidentals etc., complete</p>	SQM	3507.75
1224	<p>Supplying and fixing in position of aluminium ventilator using Powder coated aluminium section of size 2 ½" x 1 ½" and 1.28 mm thick (0.754 kg/m) for frames confirming to IS: 1948 of latest edition. The fixed and louvered glass panels shall be 5mm thick frosted glass panes. The ventilator should have required No. of louvers fitted properly in aluminium frame work having arrangement to close / open. The rate quoted shall include cost of all materials, labour, fixing charges, locking arrangements etc. all as per standard specifications, drawing and code of practice and instruction of Engineer-in-charge.</p>	SQM	4017.65
1225	<p>Providing and fixing powder coated aluminium two track sliding windows of approved colours aluminium sections of size 60 x 28 x1.20 mm (wt 0.656 kg /m) for outer frame , 38 x 17 x 1.20 mm (0.41 kg / m) for shutter box and 38 x 17 x 1.20 mm (0.44 kg/m) for inter lock 4 mm thick plain glass for panes, PVC wheels, U rubber, screws, locking arrangements etc. complete, all as per instructions of Engineer-in-charge.</p>	SQM	2968.60
1226	<p>Manufacturing, supplying and fixing in position of partitions for an approximate height of 3.20 m as detailed below:</p> <p>The bottom 90 cm and top 110 cm of the partition shall be of wooden, using 9 mm thick interior grade ISI marked (IS : 12823) three layered melamine faced prelaminate (both side) particle board of approved shade with anodised (25 micron) aluminium frame work.</p> <p>The middle 120 cm height of partition shall be of glazed using 5 mm thick plain glass and anodized aluminium frame work of approved quality. The partitions shall be rigidly fixed on floors and walls using 8 mm anchor fasteners including cutting and making good the walls and floors etc., complete.</p>	SQM	2214.40

Item No.	Description	Unit	Rate (Rs.P)
<p>FRAME WORK: The frame work shall be with anodised (25 micron) aluminium sections with suitable aluminium beadings and rubber gaskets. The bottom member shall be of size 3 3/4" x 1 3/4" and 1.70 mm thick (weight 1.312 kg/m). The middle, top and vertical members shall be of size 2 1/2" x 1 1/2" and 1.28 mm thick (weight 0.754 kg/m). The verticals shall be generally spaced at 0.90 m centers and can be suitably varied at corners, wall junctions etc, without affecting the general elevation. Generally all the vertical sections shall be taken up to ceiling height and fixing the same with RC beams/slabs for better rigidity. Rate includes cost of all materials, labour and other incidentals etc., complete.</p>	SQM	2232.60	
1227	<p>Manufacturing, supplying and fixing in position of partitions for an approximate height of 3.20 m as detailed below: The bottom ,middle and top of the partition (full portion) shall be of wooden, using 9 mm thick interior grade ISI marked (IS : 12823) three layered melamine faced prelaminate (both side) particle board of approved shade with anodised (25 micron) aluminium frame work.</p> <p>FRAME WORK: The frame work shall be with anodised (25 micron) aluminium sections with suitable aluminium beadings and rubber gaskets. The bottom member shall be of size 3 3/4" x 1 3/4" and 1.70 mm thick (weight 1.312 kg/m). The middle, top and vertical members shall be of size 2 1/2" x 1 1/2" and 1.28 mm thick (weight 0.754 kg/m). The verticals shall be generally spaced at 0.90 m centers and can be suitably varied at corners, wall junctions etc, without affecting the general elevation. Generally all the vertical sections shall be taken up to ceiling height and fixing the same with RCC beams/slabs for better rigidity. Rate includes cost of all materials, labour and other incidentals etc., complete.</p>	SQM	2965.35
1228	<p>Manufacturing, supplying and fixing in position of Aluminium partitions for an approximate height of 1.50m as detailed below: The bottom 90 cm of the partition shall be of wooden, using 9 mm thick interior grade ISI marked (IS:12823) three layered melamine faced prelaminate (both side) particle board of approved shade with anodised (25 micron) aluminium frame work. The top 0.60 m height of partition shall be of glazed using 5 mm thick frosted glass and anodized aluminium frame work of approved quality. The partitions shall be rigidly fixed on floors and walls using metal fasteners including cutting and making good the walls and floors etc. complete.</p> <p>The frame work shall be with anodised aluminium sections with suitable aluminium beadings and rubber gaskets. The bottom member shall be of size 3 3/4" x 1 3/4" and 1.70 mm thick (1.312 kg/m) approximate. The middle, top and vertical members shall be of size 2 1/2" x 1 1/2" and 1.28 mm thick (0.754 kg/m) approximate and the verticals shall be generally spaced at 0.90 m centers and can be suitably varied at corners, wall junctions etc, without affecting the general elevation. Rate includes cost of all materials, labour and other incidentals etc., complete</p>	SQM	2965.35

Item No.	Description	Unit	Rate (Rs.P)
1229	<p>Manufacturing, supplying and fixing in position of anodised (25 micron) aluminium single leaved/double leaved glazed door of overall size 1.00 x 2.10m with suitable frame work as per the following specification and instructions of Engineer- in- charge.</p> <p>The alround vertical and horizontal outer frame shall be with 4" x 1$\frac{3}{4}$" x 1.60 mm (unit wt. 1.312 kg/m)sections and for door shutter the bottom member shall be with 3$\frac{3}{4}$" x 1$\frac{3}{4}$" x 1.70 mm thick (unit wt. 1.312 kg/m) shutter top and verticals shall be of size 1$\frac{3}{4}$" x 1$\frac{3}{4}$" x 1.52 mm thick (unit wt. 0.885 kg/m) and shutter divider shall be 2 nos of of 1$\frac{3}{4}$" x 1$\frac{3}{4}$" x 1.70 mm (unit wt. 0.885 kg/m) with necessary beadings and rubber gaskets as per standard specifications. The upper panel of 120 cm shall be with 5 mm thick plain glass and lower panel of 90cm shall be with 9 mm thick interior grade ISI marked (IS:12823) three layered melamine faced prelaminate (both side) particle board . Door shall be provided with 2 Nos. of 300 mm long anodized aluminium handle, One No. of ISI marked heavy duty door closer of approved brand, One No. 200 mm long anodized aluminium tower bolt, suitable lock (4 lever), required top and bottom pivots, all as per specification of Engineer in charge. Rate includes cost of all materials, labour and other incidentals etc., complete</p>	SQM	3165.55
1230	<p>Supplying and fixing in position of aluminium ventilator using anodised (25 micron) aluminium section of size 2$\frac{1}{2}$" x 1$\frac{1}{2}$" and 1.28 mm thick (0.754 kg/m) for frames confirming to IS: 1948 of latest edition. The fixed and louvered glass panels shall be 5mm thick frosted glass panes. The ventilator should have required No. of louvers fitted properly in aluminium frame work having arrangement to close / open. The rate quoted shall include cost of all materials, labour, fixing charges, locking arrangements etc. all as per standard specifications, drawing and code of practice and instruction of Engineer-in-charge.</p>	SQM	3854.20
1231	<p>Providing and fixing anodised (25 micron) aluminium two track sliding windows of approved colours aluminium sections of size 60 x 28 x1.20 mm (wt 0.656 kg /m) for outer frame , 38 x 17 x 1.20 mm (0.41 kg / m) for shutter box and 38 x 17 x 1.20 mm (0.44 kg/m) for inter lock 4 mm thick plain glass for panes, PVC wheels, U rubber, screws, locking arrangements etc. complete, all as per instructions of Engineer-in-charge.</p>	SQM	2669.75
1232	<p>Providing false ceiling at all heights using the following ceiling tiles. The scope of work includes providing and fixing frame of grid size 600 mm x 600 mm or thereabouts using GI sections of main tees of size 24mm x 38mm x, cross tees of size 24mm x 38mm, wall angles of size 19mm x 19mm , suspended by hangers of ceiling/ stay angles / G I wires of 2mm x 2 ply of 8' length screwed with suitable bullets of size 45 to 50mmx 8mm size to RCC roof ceiling / steel trusses etc. complete. hangers and height adjustment clips if any shall also to be provided wherever light fixtures / AC grills / diffusers are flush to the ceiling frame work and the ceiling boards have to made alright accordingly. Rate to include cost of all materials involved including suitable fasteners, screws, etc., , labour charges and all other incidentals etc., Complete. All as per standard / manufacturers specifications and instructions of Engineer-in- charge.</p>		

Item No.	Description	Unit	Rate (Rs.P)
A	7.5MM NANO TILES 600mm X 600mm	SQM	949.00
B	4MM EVEREST TILES OSANIC 600mm X 600mm	SQM	1037.75
1233	Providing and fixing in position of boards/sheets/tiles of approved quality for false ceiling. Rate includes cost of all materials, conveyance, cutting to required sizes to suit the false ceiling frame work grids, wastages, supply & fixing with necessary nails/screws, all labour etc. complete. (Frame work will be paid separately)		
A	12 mm flat pressed 3 layer medium density particle boards - Grade - I	SQM	621.20
	12 mm thick plain/semi perforated or with design ceiling tiles of BWP type phenol formaldehyde synthetic resin bonded pressed conforming to IS 3087.	SQM	632.25
B			
C	3 mm thick translucent white acrylic plastic sheets.	SQM	878.30
D	20 mm thick thermocole boards. (22 K.G/CUM)	SQM	268.35
1234	Supply and fixing the following boards/sheets of approved brand & quality in panelling fixed in aluminium doors/window shutters/partition frames etc. with C.P brass/stainless steel screws etc. complete, all as per drawings, specifications and instructions of Engineer in charge. Rate includes cutting to required sizes, wastages etc.complete. Rate excludes cost of respective frame works.		
A1	MDF Boards or equivalent of 6 mm thick (Regular grade)	SQM	303.65
A2	MDF Boards or equivalent of 18 mm thick (Regular grade)	SQM	680.85
A3	Commercial plywood 6 mm thick - M.R Grade - (Anchor/Swati or equivalent)	SQM	595.60
A4	Commercial plywood 12 mm thick - M.R Grade- (Anchor/Swati or equivalent)	SQM	824.65
A5	Commercial plywood 6 mm thick-Synthetic resin bonded - (Anchor/Swati or equivalent)	SQM	595.60
A6	Commercial plywood 12 mm thick-Synthetic resin bonded- (Anchor/Swati or equivalent)	SQM	1222.35
A7	Cement bonded particle boards - 6 mm thick (Bison panel)	SQM	339.95
A8	Cement bonded particle boards - 10 mm thick (Bison panel)	SQM	489.10
A9	Cement bonded particle boards - 12 mm thick (Bison panel)	SQM	588.50
A10	Cement bonded particle boards - 16 mm thick (Bison panel)	SQM	685.00
A11	Both sides pre laminated Cement bonded particle boards - 6 mm thick (Bison panel)	SQM	675.50

Item No.	Description	Unit	Rate (Rs.P)
A12	Both sides pre laminated Cement bonded particle boards - 8 mm thick (Bison panel)	SQM	725.20
A13	Both sides pre laminated Cement bonded particle boards - 10 mm thick (Bison panel)	SQM	774.95
A14	Both sides pre laminated Cement bonded particle boards - 12 mm thick (Bison panel)	SQM	843.30
A15	Both sides pre laminated Cement bonded particle boards - 16 mm thick (Bison panel)	SQM	935.60
A16	Plain particle boards- 9 mm thick-Regular Grade-(Novapan-Prime or equivalent)	SQM	366.05
A17	Plain particle boards- 12mm thick-Regular Grade-(Novapan-Prime or equivalent)	SQM	438.15
A18	Plain particle boards- 18mm thick-Regular Grade-(Novapan-Prime or equivalent)	SQM	567.75
A19	Plain particle boards- 25mm thick-Regular Grade-(Novapan-Prime or equivalent)	SQM	760.60
A20	Plain particle boards- 35mm thick-Regular Grade-(Novapan-Prime or equivalent)	SQM	1136.25
A21	Plain particle boards- 9 mm thick-Exterior Grade-(Novapan-Prime or equivalent)	SQM	419.50
A22	Plain particle boards- 12mm thick-Exterior Grade-(Novapan-Prime or equivalent)	SQM	509.60
A23	Plain particle boards- 18mm thick-Exterior Grade-(Novapan-Prime or equivalent)	SQM	665.90
A24	Plain particle boards- 25mm thick-Exterior Grade-(Novapan-Prime or equivalent)	SQM	897.30
A25	Plain particle boards- 35mm thick-Exterior Grade-(Novapan-Prime or equivalent)	SQM	1353.75
A26	Pre laminated (one side) particle boards - 9 mm thick - (Emotive or equivalent)	SQM	532.60
A27	Pre laminated (both sides) particle boards - 9 mm thick - (Emotive or equivalent)	SQM	538.85
A28	Pre laminated (one side) particle boards - 12 mm thick - (Emotive or equivalent)	SQM	614.60
A29	Pre laminated (both sides) particle boards - 12 mm thick - (Emotive or equivalent)	SQM	621.50
A30	Pre laminated (one side) particle boards - 18 mm thick - (Emotive or equivalent)	SQM	718.15
A31	Pre laminated (both sides) particle boards - 18 mm thick - (Emotive or equivalent)	SQM	724.70

Item No.	Description	Unit	Rate (Rs.P)
A32	Pre laminated (one side) particle boards - 25 mm thick - (Emotive or equivalent)	SQM	902.30
A33	Pre laminated (both sides) particle boards - 25 mm thick - (Emotive or equivalent)	SQM	909.05
1235	Supplying and fixing of vertical Venetian blinds 100mm wide with dual colour of approved make (Hunter Douglas make or equivalent) and shade and / as decided by BHEL - for windows / ventilators. Rate inclusive of cost of all materials, labour for fixing and incidentals etc., complete	SQM	1191.95

Item No.	Description	Unit	Rate (Rs.P)
XIII - PILE WORKS			
1301	Boring, providing and installing bored cast-in-situ reinforced cement concrete piles of grade M-25 of specified diameter and length below the pile cap, to carry a safe working load not less than specified, excluding the cost of steel reinforcement but including the cost of boring, with bentonite solution and temporary casing of appropriate length for setting out and removal of same and the length of the pile to be embedded in the pile cap etc. all complete, including removal of excavated earth with all lifts and leads (Length of pile for payment shall be measured upto bottom of pile cap).		
A	300 mm dia piles	R.M	1155.05
B	400 mm dia piles.	R.M	1297.00
C	450 mm dia piles.	R.M	1688.50
1302	Boring, providing and installing cast in situ single under reamed vertical piles of specified diameter & required length below grade beam/pile cap in M 35 cement concrete piles using 20 mm & down grade hard broken granite stone jelly with necessary reinforcement including bailing out water, mobilisation of necessary plants, equipments, materials etc. complete. Rate also includes cost of boring with bentonite solution, chisseling, cutting the pile to the required cut off level, leaving necessary dowel to grade beam/pile cap etc. all as per standard specifications and as directed by the Engineer-in -charge. (Length of pile for payment shall be measured upto the bottom of grade beam/pile cap. Rate excludes cost of cement, reinforcement steel & fabrication charges for reinforcement)		
A	300 mm dia piles	R.M	1736.45
B	400 mm dia piles	R.M	1934.10
C	450 mm dia piles	R.M	2049.55

Item No.	Description	Unit	Rate (Rs.P)
XIV - HORTICULTURE			
1401	Labour charges for carrying out the following. Scope includes all labour, relevant tools & plants required for the work, disposing off all the wastes, cut leaves etc. in the nearby areas within a lead of 100 metre etc. complete. All as per instructions of Engineer-in-charge.		
A	Mowing of lawns neatly to uniform levels. (By means of blade/ mower)	SQM	2.30
B	Cutting all types of hedges to the required & uniform height and width.	R.M	3.85
C	Cutting & trimming topiary work for various shrubs, domes etc. to the required sizes, shapes etc. complete.	EACH	15.05
1402	Conveying tree saplings / plants from BHEL and planting the same in the pits excavated (in the premises of BHEL), initial watering, forming bed etc., all as per instructions of Engineer-in-charge. Tree saplings / plants will be supplied at BHEL Nursery at free of cost. Rate includes conveyance, loading, unloading, lifting and planting, initial watering etc., complete.	EACH	3.65
1403	Maintaining the shrub plants available at various locations in BHEL. Maintenance covers watering once in two days, weeding, mulching the top soil to a depth of 15 cm once in three months, making basin to proper size, manuring, cutting & trimming whenever necessary, cleaning the areas etc. complete. Replanting is also to be done as and when necessary. Rate includes all labour, tools, hose pipes, water carts, all incidentals etc. complete. All as per instructions of Engineer-in-charge. Required manure & plants will be issued by BHEL at Stores or Nursery at free of cost. Contractor has to transport the same to site of works.	EACH	2.70
1404	Maintaining the domes available at various locations in BHEL. Maintenance covers watering once in two days, weeding, mulching the top soil to a depth of 15 cm once in three months, making the basin to proper size, manuring, pruning/trimming topiary work once in a month, cleaning the areas, disposing off all wastes, cut branches, leaves etc. in the nearby areas within a lead of 50 metre etc. complete. Replanting is also to be done as and when necessary. Rate includes all labour, tools, hose pipes, water carts, all incidentals etc. complete. All as per instructions of Engineer-in-charge. Required manure & plants will be issued by BHEL at Stores or Nursery at free of cost. Contractor has to transport the same to site of works. (Payment will be made for every month).	EACH	27.00

Item No.	Description	Unit	Rate (Rs.P)
1405	Maintaining the hedges (upto a height of 1.50 m) available at various locations in BHEL. Maintenance covers watering once in two days, weeding, mulching the top soil to a depth of 15 cm once in three months, making basin along the hedges, manuring & cutting, pruning, trimming the hedges once in a month, cleaning the areas, disposing off all wastes, cut branches, leaves etc. in the nearby areas within a lead of 100 metre etc. complete. Replanting is also to be done as and when necessary. Rate includes all labour, tools, hose pipes, water carts, all incidentals etc.complete. All as per instructions of Engineer-in-charge. Required manure, hedge plants will be issued by BHEL at Stores or Nursery at free of cost. Contractor has to transport the same to site of works. (Payment will be made for every month).	R.M	1.65
1406	Maintaining rose beds at various locations in BHEL. Maintenance covers watering once in two days, weeding, mulching the top soil to a depth of 15 cm once in 15 days, making basin for rose plants, manuring, cutting & trimming whenever necessary, clearing the jungle, leveling the areas once in 15 days etc.complete. Replanting is also to be done as and when necessary. Rate includes all labour, tools, hose pipes, water carts, all incidentals etc.complete. All as per instructions of Engineer-in-charge. Required manure & plants will be issued by BHEL at Stores or Nursery at free of cost. Contractor has to transport the same to site of works. (Payment will be made for every month).	SQM	2.25
1407	Maintaining and safeguarding the lawns including flower beds available at various locations in BHEL. Maintenance covers watering once in two days, periodical weeding, mowing, scraping, raking, replacing flower beds, mulching the top soil and forming basins etc.all once in 45 days, manuring, cleaning the areas, disposing off all wastes, dried leaves etc. in the nearby areas within a lead of 100 metre etc.complete. Re-lawn is also to be done as and when necessary. Rate includes all labour, tools, hose pipes, water carts, all incidentals etc.complete. All as per instructions of Engineer-in-charge. Required manure, plants & grass will be issued by BHEL at Stores or Nursery at free of cost. Contractor has to transport the same to site of works. (Payment will be made for every month).	SQM	1.65
1408	Maintenance and protection of avenue tree plants/coconut tree seedlings etc. available at various locations in BHEL. Maintenance covers watering once in two days, protecting the plants from cattle menace & theft by providing thorny fencing, periodical weeding, maintaining the area free from other vegetation growth, mulching the top soil and forming basin, manuring, cleaning the area etc.complete. Rate includes all labour, tools, hose pipes, water carts, all incidentals etc.complete. All as per instructions of Engineer-in-charge. Required manure & plants will be issued by BHEL at Stores or Nursery at free of cost. Contractor has to transport the same to site of works. (Payment will be made for every month).	EACH	6.75

Item No.	Description	Unit	Rate (Rs.P)
1409	Maintaining the potted plants available at Nursery & other locations by watering once in two days, mulching and weeding the soil once in a fortnight, application of manure/fertilizer/pesticides as and when required (normally three times in an year) pruning and shaping as and when required, repotting the plant once in a year, replacement of broken pots (pots & plants will be supplied by BHEL), propogation of different species of pots as directed etc.complete. Rate includes all labour, tools, hose pipes, water carts, all incidentals etc.complete. All as per instructions of Engineer-in-charge. Required manure / fertilizer / pesticides, pots & plants will be issued by BHEL at Stores or Nursery at free of cost. (Payment will be made for every month).	EACH	2.70

Item No.	Description	Unit	Rate (Rs.P)
XV - MISCELLANEOUS			
1501	Grouting the H.D bolts, underneath the base plates etc., after alignment with wet cement grout (1:1), all as per standard specifications. Rate includes cleaning the sleeves/pockets, tools and plants required for the work etc., complete except cement which will be supplied by BHEL at stores at free of cost.	CUM	16000.65
	Cement consumption - 1020.00 K.G/CUM		
1502	Grouting the H.D bolts, underneath the base plates etc., after alignment with non-shrink high strength cementitious grout of such as Tec. Grout 40 or Pidigrout 10M or Flogrout 60 or Conbextra GP2 or any other equivalent grout, all as per instructions of Engineer in charge and as per standard specifications. Rate includes cost of non-shrink grout, cleaning the sleeves/pockets, tools, labour etc., complete.	CUM	53487.40
1503	Precasting and fixing in position of reinforced cement concrete (1:2:4) fencing post (using 12 to 20 mm size hard broken granite stone jelly) of size 100 x 100 mm at top and 150 x 150 mm at bottom and 1.70 m high of which 45 cm will be embedded in cement concrete base below ground level. Rate includes shuttering, casting, finishing, curing, conveying and fixing in position but excluding cost of excavation, concrete base and fabrication charges for reinforcement which will be paid separately under respective items.	EACH	179.05
	Cement consumption - 8.64 K.G/ Each		
1504	Precasting and fixing in position of reinforced cement concrete (1:2:4) fencing post (using 12 to 20 mm size hard broken granite stone jelly) of size 100 x 100 mm at top and 150 x 150 mm at bottom and 2.10 m high of which 45 cm will be embedded in cement concrete base below ground level. Rate includes shuttering, casting, finishing, curing, conveying and fixing in position but excluding cost of excavation, concrete base and fabrication charges for reinforcement which will be paid separately under respective items.	EACH	212.05
	Cement consumption - 10.56 K.G/ Each		
1505	Precasting and fixing in position of reinforced cement concrete (1:2:4) fencing post (using 12 to 20 mm size hard broken granite stone jelly) of size 200 x 200 x 3650 mm of which 600 mm (approx.) will be embedded in cement concrete base below ground level. Rate includes making necessary groove arrangements on two sides of post for inserting 50 mm thick precast slabs, shuttering, casting, embedding 'Y' angle with necessary lugs, finishing, curing, conveying the posts including all lead, erection in position by embedding in foundation concrete up to a depth of 600 mm (approx.) below ground level true to plumb, line, level etc.complete, all as per drawings and as per instructions of Engineer in charge. Rate excludes cost of excavation, concrete base, precast slabs and it's inserting/fixing charges, fabrication charges for reinforcement and 'Y' angle which will all be paid separately under respective items.	EACH	880.25
	Cement consumption - 40.32 K.G/ Each		

Item No.	Description	Unit	Rate (Rs.P)
1506	Conveying RCC fencing post of overall height 1.70 to 2.10 m from stores/stack yard to site of work and fixing in position, line, level etc. Earth work excavation and concrete base will be paid separately.	EACH	31.35
1507	Providing and fixing G.I barbed wire of 12 G, 2 ply and 4 barbs with spacing of barbs at 80 mm c/c for fencing including unwinding the coil and fixing in position with proper tension and alignment by means of providing G.I staples on wooden plugs or G.I binding wire tied to 6 mm bar ribs provided in the posts etc. complete.	R.M	13.75
1508	Conveying G.I barbed wire, G.I staples/binding wires etc. from BHEL stores and fixing in position for fencing including unwinding the coil, fixing it in posts with proper tension and alignment by means of G.I staples on wooden plugs or G.I binding wire tied to 6 mm bar ribs provided in the posts etc. complete. Rate excludes G.I barbed wire and G.I staples / binding wire which will be supplied by BHEL at stores at free of cost.	R.M	1.45
1509	Conveyance of earth, sand, gravel, rough stone, broken stone, brick bats (debris) etc. by contractor's own lorry including loading, leading, unloading, stacking or spreading, all as per instructions of Engineer-in-charge. Payment for conveyance of earth will be made based on pit measurement and for other items based on stack measurements.		
A	0 - 1 Km	CUM	114.00
B	Beyond 1 Km but upto 2 Km	CUM	121.65
C	Beyond 2 Km but upto 3 Km	CUM	130.25
D	Beyond 3 Km but upto 4 Km	CUM	138.80
E	Beyond 4 Km but upto 5 Km	CUM	147.40
1510	Transporting the garbage, horticulture waste etc., collected from houses, dustbins and other places by lorry having a capacity of minimum 300 cft covering with suitable net to avoid spilling during transport and unloading at the earmarked place on the eastern side of MHD. (Nearly 5 KM from the centre point of Kailasapuram) Rate also includes topping the dust bins, segregation of bio-degradable & non-bio-degradable waste at respective dust bins itself, collection, loading, all lead, unloading, hire & running charges of lorry, tools required, all labour and all other incidentals etc.complete and as directed by the department. Trip sheet is to be maintained for each load that will be certified by the concerned official & by the security at the gate which will form the basis for making payment. Each load would exit only through the main entrance of Township or as directed by the Engineer in charge. Rate to be quoted for one trip of lorry load of 300 cft garbage.	EACH	1014.05

Item No.	Description	Unit	Rate (Rs.P)
1511	Conveyance of debris generated by dismantling and other modification works by various departments, factory wastes discarded cotton waste, slag, cut tree branches, dried leaves, abandoned broken glass, water closets, urinals, flush tanks, broken furniture, broken refractory bricks, AC materials, hedge cuttings and all other debris and waste materials from various places of factory premises where they are stacked / accumulated and transporting the same by contractor's lorry and disposing off at the specified places, all as per the instructions of Engineer-in-charge. Rate includes labour for collection of the said debris from various places, loading, leading, unloading, spreading, leveling etc. complete. Rate also includes for safe burning of dried leaves, cut pieces of tree branches, wood, waste paper etc., all by following safety precautions. Payment will be made on trip basis with a lorry load of minimum 300 cft./Trip.		
A	0-1 K.M	EACH	774.75
B	1-2 K.M	EACH	826.40
C	2-3 K.M	EACH	878.10
1512	Sweeping roads, drains, platforms, open spaces, surrounding areas of buildings, shops, parks, gardens, sides & back spaces in between bolcks, roof terrace of buildings at a maximum elevated level of 6 metre and other areas as identified & instructed by Engineer in charge. Rate includes labour, tools, brooms, malard, baskets etc., sweeping, hand picking of debris, collecting & dumping the debris in the near by dust bins/earmarked areas etc.complete. Sweeping has to be done only as and when necessary. Payment will be made only for the areas where sweeping was done.	100 SQM	13.00
1513	Cleaning & removing all unwanted things from the roof terrace of various buildings at an elevated level of 12 to 20 metre from FFL. Rate includes labour, tools, wire brush, brooms, baskets etc., sweeping and clearing off all dirt, silt, dust, leaves and other foreign matters etc. without damaging the terrace treatment and thereby collecting all the wastes in bags/baskets, lowering to ground floor without affecting the working environment & dumping the same in the near by dust bins/earmarked areas/low lying areas etc.complete. Sweeping has to be done only as and when necessary. Payment will be made only for the areas where actually the job was carried out.	100 SQM	15.60
1514	Labour charges for providing tarpaulin pandal to an area upto 25 Sq.m in ground floor / first floor and removing the same after the function is over. All materials such as tarpaulin, posts etc. will be supplied by BHEL at Stores at free of charges. Rate includes to and fro transportation of materials. (Payment will be made for each operation)	EACH	646.40
1515	Labour charges for conveying 200 litre capacity drum and pouring with full of water for function and handing over the empty drum to Stores after function is over. Drum will be supplied by BHEL at Stores at free of charges. Water has to be collected either from Township water tanks or Equalising Reservoir. Rate includes to and fro transportation.		

Item No.	Description	Unit	Rate (Rs.P)
A	At Quarters of Kailasapuram / Kamarajapuram Township.	EACH	264.05
B	At Quarters of Nehru Nagar/ burial ground	EACH	314.05
1516	Labour charges for providing Shamiana of following sizes and removing the same after the function is over. Necessary shamiana, posts etc. will be supplied by BHEL at Stores at free of charges. Rate includes to and fro transportation. (Payment will be made for each operation)		
A	40' X 40'	EACH	1597.50
B	40' X 20'	EACH	1043.90
C	20' X 12'	EACH	501.30
1517	Hire charges for providing 4 ' 40 watts tube light fitting with tube, necessary wire, plug etc. in the tarpaulin pandal / shamiana at G.F / F.F and removing the same after the function is over.	EACH	36.30
1518	Labour charges for providing stage for functions and removing the same and handing over to Stores after the programme. Necessary stage materials will be supplied by BHEL at Stores at free of charges. Rate includes to and fro transportation.	SQM	40.10
1519	Labour charges for erection of flag post and tying the flag. Rate includes digging hole, erection of post and removing the same after the function is over including refilling the hole and handing over the flag post, flag etc. to Stores after the programme. Necessary flag post and flag will be supplied by BHEL at Stores at free of charges. Rate includes to and fro transportation.	EACH	21.30
1520	Labour charges for spreading coir mat and removing the same after the function is over. Rate includes to and fro transportation, labour etc. complete. Coir mat will be issued by BHEL at Stores at free of charges.	SQM	5.90
1521	Labour charges for erection in position of column trusses and other accessories and spreading of shamiana, back drops etc. and removing and returning the same after the function is over. Column trusses, shamiana etc. will be issued by BHEL at Stores at free of charges. Rate includes to and fro transportation of materials. (Payment will be made for each operation)		
A	For stage of size 32' x 20'	EACH	1358.80
B	For stage of size 20' x 20' or 20' x 18'	EACH	1052.10
C	For stage of size 20' x 12'	EACH	750.90
1522	Carrying the following from BHEL Stores to site of work and returning the same after the function is over. Rate includes labour, to and fro transportation etc.		
A	PVC moulded chair	EACH	4.80

Item No.	Description	Unit	Rate (Rs.P)
B	Wooden chair with cushion	EACH	12.00
1523A	Labour charges for providing Shamiana of size 40' X 40' and removing the same after the function is over. Necessary shamiana, posts etc. will be supplied by BHEL at Stores at free of charges. Rate includes loading and unloading charges but transportation (to and fro) will be arranged by BHEL for all the required materials such as shamiana, bamboo posts, coir mat, stage materials, flag posts, chairs etc.	EACH	1421.45
1523B	Labour charges for providing Shamiana of size 40' X 20' and removing the same after the function is over. Necessary shamiana, posts etc. will be supplied by BHEL at Stores at free of charges. Rate includes loading and unloading charges but transportation (to and fro) will be arranged by BHEL for all the required materials such as shamiana, bamboo posts, coir mat, stage materials, flag posts, chairs etc.	EACH	911.90
1523C	Labour charges for providing Shamiana of size 20' X 12' and removing the same after the function is over. Necessary shamiana, posts etc. will be supplied by BHEL at Stores at free of charges. Rate includes loading and unloading charges but transportation (to and fro) will be arranged by BHEL for all the required materials such as shamiana, bamboo posts, coir mat, stage materials, flag posts, chairs etc.	EACH	402.30
1523D	Labour charges for providing stage for functions and removing the same and handing over to Stores after the programme. Necessary stage materials will be supplied by BHEL at Stores at free of charges transportation (to and fro) will be arranged by BHEL for all the required materials such as shamiana, bamboo posts, coir mat, stage materials, flag posts, chairs etc. but including loading and unloading charges, instead of transporting by the contractor.	SQM	32.20
1523E	Labour charges for loading, unloading and erection of flag post and tying the flag. Rate includes digging hole, erection of post and removing the same after the function is over including refilling the hole and handing over the flag post, flag etc. to Stores after the programme. Necessary flag post and flag will be supplied by BHEL at Stores at free of charges and transportation (to and fro) will be arranged by BHEL for all the required materials such as shamiana, bamboo posts, coir mat, stage materials, flag posts, chairs etc.	EACH	16.90
1523F	Labour charges for loading, unloading and spreading coir mat and removing the same after the function is over Coir mat will be issued by BHEL at Stores at free of charges.	SQM	1.10
1523G	Labour charges for erection in position of column trusses and other accessories and spreading of shamiana, back drops etc. and removing and returning the same after the function is over. Column trusses, shamiana etc. will be issued by BHEL at Stores at free of charges. Rate excludes to and fro transportation of materials but includes loading and unloading charges . For stage of size 32' x 20'	EACH	1072.80

Item No.	Description	Unit	Rate (Rs.P)
1523H	Labour charges for erection in position of column trusses and other accessories and spreading of shamiana, back drops etc. and removing and returning the same after the function is over. Column trusses, shamiana etc. will be issued by BHEL at Stores at free of charges. Rate excludes to and fro transportation of materials but includes loading and unloading charges . For stage of size 20' x 20' or 20' x 18'	EACH	804.60
1523I	Labour charges for erection in position of column trusses and other accessories and spreading of shamiana, back drops etc. and removing and returning the same after the function is over. Column trusses, shamiana etc. will be issued by BHEL at Stores at free of charges. Rate excludes to and fro transportation of materials but includes loading and unloading charges . For stage of size 20' x 12'	EACH	536.40
1523J	Carrying the PVC moulded chair from BHEL Stores to site of work and returning the same after the function is over. Rate includes labour, loading and unloading charges but excludes to and fro transportation etc.	EACH	0.85
1523K	Carrying the Wooden chair with cushion from BHEL Stores to site of work and returning the same after the function is over. Rate includes labour, loading and unloading charges but excludes to and fro transportation etc	EACH	2.10
1524	Maintenance of BG tracks of BHEL siding, ensuring perfect level, cant, alignment, straightness etc. Scope includes tightening of fish plates, oiling & greasing of fish plates, driving the spikes, beating the steel keys and cotters, checking the tie bars to keep the rails in position and gauge, packing the ballast (murrum/stone), maintaining the width of earthen embankment, cutting of unwanted trees/tree branches on either sides of tracks, clearing off the jungle & bushes to a maximum width of 4.00 m along the track and handing over the cut woods to stores etc. complete, all as per standard railway practices and also taking periodic gauge/super elevation/curve readings and submission of records. Payment will be made for the length of track for which maintenance works attended to. Tools, oil, spares etc. required for the work will be supplied by BHEL at stores at free of charges. Rate will be Paid Per RM / One Operation	R.M	49.60
1525	Maintenance of point & crossing 1 in 8 ½ in BG by thorough packing and consolidation of ballast. Scope of work includes to bring the track to correct longitudinal and cross levels, super elevation on curve, boxing and tidying up the track to prescribed parameters with tolerance as allowed as per IRPWM, cleaning of fish plates, switches, point level, box assembling, oiling and greasing of joint / fish plates, moveable / sliding portion, cutting of unwanted trees/tree branches, clearing off jungle, bushes in & along the point & crossing area and handing over the cut woods to stores and taking periodic reading for maintaining the point & crossing register and submission of record, all as per standards of Indian Railways. Tools, oil, spares etc. required for the work will be supplied by BHEL at stores at free of charges. Rate will be Paid Per Point and Crossing per One time Operation	EACH	3693.55

Item No.	Description	Unit	Rate (Rs.P)
1526	Cutting 90/105 lbs rail with hacksaw blade to the correct square in laid condition/free condition. Rate includes labour, tools, consumables, lead, lift etc. complete, all as directed by the Engineer-in-charge. Payment will be made for each Cutting.	EACH	131.60
1527	Drilling 32 mm dia hole in 90/105 lbs rails to match with the fish plate holes in laid condition / free condition. Rate includes labour, tools, consumables, lead, lift etc. complete, all as directed by the Engineer-in-charge. Payment will be made per Hole.	EACH	40.60
1528	Removing the ballasts (metal/murram), earth etc.around the sleepers and replacing to the existing unserviceable sleepers of various lengths from the BG track and relaying with new sleepers in the same place by duly fixing the sleepers with the rail and its fittings and packing the sleepers completely with ballasts (metal/murram) to correct level, cant, alignment etc.complete. For replacement, sleepers (Wooden/PSC/CST-9/Pot sleepers) and other connected accessories, ballasts etc. will be supplied by BHEL at stores at free of cost. Payment will be made per Sleeper	EACH	320.45
1529	Carrying from stacks, leading and spreading of 40/50 mm size metal/gravel/murram at any section of the BG track, all as per instructions of Engineer-in-charge. Rate includes all labour, incidentals etc. complete.	CUM	103.90
1530	Removing and replacing with 90/105 lbs rails for the track, all as per standard specifications. Removed rails and other materials shall be stacked properly at the locations 'or' conveyed and handed over at stores, all as directed by the Engineer-in-charge. 90/105 lbs rails & connected required materials will be supplied at free of cost at RPS/Civil Stores/Stack yard. Rate includes conveyance, handling, straightening, drilling holes in rails to suit fish plates, hacksaw cutting the rail if required, all labour for removing the existing and replacing with new one in correct position, alignment, all other incidentals etc.complete.	M.T	3793.35
1531	Cleaning & removing all the unwanted things from the rain water gutters available at an elevation of 12 to 20 m from FFL and making the gutter free from all accumulations, all as per instructions of Engineer-in-charge. Scope includes thorough cleaning off all dirt, dust, silt, leaves, other foreign matters etc. complete from the gutters using wire brush without damaging to the existing treatment given in the gutters, collecting the wastes in bags, lowering and conveying the same to the floor & dumping in the low lying areas. Rate includes all labour, tools, other incidentals etc. complete. Since the work is to be carried out at elevated levels/DSL EOT crane areas, the contractor is required to take all safety precautions during working and obtain work permit from the concerned departments. Working hour is restricted as it depends on shut down by the Production department that may not be more than 4 hour at a stretch and only intermittent.	SQM	11.30

Item No.	Description	Unit	Rate (Rs.P)
1532	Removing beehive of any size carefully in all levels at stage beams, columns, slabs, ladders etc., in the overhead tank or other buildings/structures etc. While removing beehive, the contractor should follow all safety rules & regulations, all as per instructions of Engineer-in-charge.	EACH	330.00
1533	Carrying from BHEL stores to site of work and fixing GI chainlink mesh for fencing including unwinding the roll and fixing in proper position, tension and alignment by means of MS flat as stiffeners, drilled with necessary holes or as the case may be and fixed with RCC / MS fencing posts by bolts, nuts, washers etc., complete. Payment will be made based on the laid area of chainlink mesh only. Rate includes cost of labour, tools & plants and all other incidentals etc., complete but excludes cost of chain link mesh, MS flats, bolts, nuts and washers which will be supplied by BHEL at stores at free of cost. Fabrication charges for MS flats including drilling holes etc. will be paid under separate item.	SQM	16.50
1534	Providing and fixing G.I. chain link fabric fencing of required width in mesh size 50x50 mm including strengthening with 2 mm dia wire or nuts, bolts and washers as required complete as per the direction of Engineer-in-charge.		
	a) Made of G.I. wire of dia 4 mm.	EACH	475.15
	Made of G.I. wire of dia 4 mm, PVC coated to achieve outer dia. not less than	EACH	506.35
	b) 5 mm in required colour and shade.		
1535	Providing and fixing G.I. chain link fabric fencing of required width in mesh size 25x25 mm made of G.I. wire of dia 3 mm including strengthening with 2 mm dia wire or nuts, bolts and washers as required complete as per the direction of Engineer-in-Charge.	SQM	569.90
1536	Drilling holes for the following diameter in Industrial Reinforced cement concrete floor or in machine foundation using power drilling machine in proper manner to a maximum depth of 200 mm as per standard specification and fixing the anchor bolts through the holes provided in the machine with the drilled holes in the shop floor as per the instructions of Engineer in charge. The power and compressed air required for drilling holes will be supplied by BHEL at free of cost. The quoted rate shall include all labour charges for drilling holes only and also include hire and running charges for machineries, tools and plants , loading, leading , conveyance and cleaning the debris etc complete.		
A	10- 14 mm diameter	EACH	65.00
B	15 – 18 mm diameter	EACH	76.85
C	19 – 23 mm diameter	EACH	88.70
D	24 – 28 mm diameter	EACH	100.50

Item No.	Description	Unit	Rate (Rs.P)
1537	Cleaning of Septic tanks including removal of all sludge/waste material with septic tank cleaning vehicle of tank capacity of 7000 litres and conveying the waste to all leads and disposal off. Rate includes hire and running charges for the septic tank cleaning vehicle with driver and labour for cleaning the septic tank, cost of tools and plants, all incidental charges, leading disposing off the sewage and wastages etc as per the instructions of Engineer in Charge. Payment will be made for one trip up to a maximum of 7000 litres quantity of sewage	TRIP	2687.50
1538	Attending to leak at roof slab and wall joint. The scope of work includes clearing the tiled terrace surfaces to be free of dust, loose particles, algae growth and atmospheric deposits, filling small blow holes if any with CERAFIL 45/ TEC TILE 12/ Sika Grout/NACC Tile Grout/Dr. Fixit Crack-X and providing primer and top coat of CERAFLEX/TEC WAVE 3000/Sika Raingard/NACC High Flex single component/Dr. Fixit New Coat highly flexible membrane coating including curing adequately .All as per manufacture's recommendation/ standard specifications and instructions of Engineer-in-charge. Rate quoted includes cost of all materiasl, labour charges, conveyance,tools and all other incidental charges etc.complete -for In accessible areas One Primer and one top coat	SQM	335.50
1539	Attending to leak at roof slab and wall joint. The scope of work includes clearing the tiled terrace surfaces to be free of dust, loose particles, algae growth and atmospheric deposits, filling small blow holes if any with CERAFIL 45/ TEC TILE 12/ Sika Grout/NACC Tile Grout/Dr. Fixit Crack-X and providing primer and top coat of CERAFLEX/TEC WAVE 3000/Sika Raingard/NACC High Flex single component/Dr. Fixit New Coat highly flexible membrane coating including curing adequately .All as per manufacture's recommendation/ standard specifications and instructions of Engineer-in-charge. Rate quoted includes cost of all materiasl, labour charges, conveyance,tools and all other incidental charges etc.complete. -for In accessible areas. One primer and two top coats	SQM	518.30

Item No.	Description	Unit	Rate (Rs.P)
1540	Providing two coats of CERALASTIC/TEC WAVE 2000/Sika raingard/NACC roof coating /Dr. FIXIT PIDIFIN 2K water proofing membrane coating followed by one bond coat of CERA BOND SBR/TEC BOND SBR/Sika latex/NACC Latex / Dr. FIXIT PIDICRETE URP SBR LATEX over the membrane coating and providing cement plastering 6mm thick in CM 1:4 admixed with general purpose water proofing compound of respective products and curing adequately.All as per manufacturer's recommendation / standard specifications and instructions of Engineer-in-charge.The scope of work includes dismantling the existing damaged weathering course and tiles to expose to the RCC slab and finsihing to match with the existing weathering course.. Rate quoted includes cost of all materials except cement which will be issued free of cost at BHEL stores, labour charges, conveyance, tools and all other incidental charges etc., complete. Replacing the damaged tiles and re-pointing where ever required which will be paid under separate item.- for-accessible areas.(CEMENT CONSUMPTION=2.74KG/SQM)	SQM	338.25
1541	Attending crack filling at parapet level with pressure grouting: The scope of work includes routing out the cracks with a mechanically operated groove cutter and sealing the groove with flexible sealant - CERA CRACK FILLER/TEC KRACK FILLER/Sika CRACK SEAL/NACC CRACK FILLER/Dr. FIXIT CRACK-X PASTE and allowing the sealant to set overnight, driving grouting nozzles at intervals of 1M and grouting neat cement slurry admixed with expansive grouting additive CERA EXPAN 250/TEC SWELL/Sika INTRA PLAST/NACC EXPAN/Dr. FIXIT PIDICRETE AM 250 and providing two coats of CERAFLEX/TEC WAVE 3000/Sika RAINGARD/NACC HIGH FLEX /Dr. FIXIT NEW COAT roof coating single component flexible membrane for a width of 15cms aligned to the centre of the crack. All as per manufacturers recommendations / standard specifications and instructions of Engineer-in-charge. Rate quoted includes cost of all materiasl, labour charges, conveyance, tools and all other incidental charges etc., complete,but excluding cost of cement which will be issued free of cost at BHEL stores (CEMENT CONSUMPTION=0.35 Kg/SQM)	SQM	151.25
1542	Attending Crack filling at parapet level without pressure gouting. The scope of work includes routing out the cracks with a mechanically operated groove cutter and sealing the groove with flexible sealant - CERA CRACK FILLER/TEC KRACK FILLER/Sika CRACK SEAL/NACC CRACK FILLER/Dr. FIXIT CRACK-X PASTE and providing two coats of CERAFLEX/TEC WAVE 3000/Sika RAIN GARD/NACC ROOF COATING/Dr. FIXIT NEW COAT highly flexible membrane for a width of 10cms aligned to the centre of the crack. All as per / manufacturers recommendations/ standard specifications and instructions of Engineer-in-charge. Rate quoted includes cost of all materials, labour charges,conveyance, tools and all other incidental charges ,etc. complete.	RM	112.75

Item No.	Description	Unit	Rate (Rs.P)
1543	Drilling pockets and fixing PVC Nipples in position along weak concrete junctions and leakage points in walls/floor and pressure grouting CERA EXPAN 250 / TEC SWELL/Sika INTRA PLAST/NACC EXPAN / Dr. FIXIT PIDICRETE AM 250 expansive grouting additive admixed with cement slurry using hand operated grouting pump. The scope also includes plugging the grout hole with CERA PLUG/TEC STOP / Sika HYDRO PLUG / NACC PLUG / Dr. FIXIT INSTANT LEAK PLUG .All as per manufacturer's recommendations/ standard specifications and instructions of Engineer-in-charge. Rate quoted includes cost of all materials, labour charges, conveyance, tools and all other incidental charges except cement which will be issued free of cost at BHEL stores. (CEMENT CONSUMPTION=0.35 Kg/POINT) .	POINT	145.75
1544	Providing one coat of Antifungal coating - tec touch /Cera re-played/Sika Multi guard or Sika gard 67/NACC acrylic/Dr. FIXIT DAMPGAURD - protective and decorative coating system as per manufacturer's recommendations/ standard specifications and instructions of Engineer-in-charge.The scope of work includes surface preparation including cleaning the wall surfaces to be free of previous coatings, dust, loose particles, algae growth and atmospheric deposits, filling small blow holes if any with putty. Rate quoted includes cost of all materials, labour charges, conveyance, tools and all other incidental charges etc., complete.	SQM	203.20
1545	Arresting leakage through RCC Construction joints The scope of work includes routing out the horizontal cracks along /contruction joints to expose the RCC joint and applying CERA SEAL / TEC POLYSEAL G / Sika Crack Seal / NACC poly seal gun grade polysulphide sealant / Dr.FIXIT PU SEALANT. The scope also includes application of CERAFLEX / TEC WAVE 3000/Sika Rain Gard/NACC Roof Coating / Dr. FIXIT NEW COAT single component flexible membrane with intermediate layer of cloth over the exposed area after allowing the PS(polysulphide sealant) to cure for 72 hours. All as per manufacturers recommendations / standard specifications and instructions of Engineer-in-charge. Rate quoted includes cost of all materials, labour charges, conveyance, tools and all other incidental charges etc., complete.	SQM	499.10

Item No.	Description	Unit	Rate (Rs.P)
1546	<p>Arresting leakage through Masonry construction joints. The scope of work includes routing out the vertical cracks along construction joints and providing a bond coat of CERA BOND SBR / TEC BOND SBR /Sika Latex Power/NACC latex/ Dr. FIXIT PIDICRETE URP SBR LATEX followed by filling the cracks with repair mortar admixed with CERA EXPAN 250 / TEC SWELL/Sika Intra Plast/NACC Expan/Dr. FIXIT PIDICRETE AM 250. The scope also includes placing of grouting nipples on the neatly finished surface at adequate spacing and grouting cement slurry admixed with CERA EXPAN 250 / TEC SWELL/Sika Intra Plast/NACC Expand/Dr. FIXIT PIDICRETE AM 250 using hand operated grouting pump. The treated surface shall then be finished with two coats of CERAFLEX / TEC WAVE 3000 / Sika Rain gard/NACC Roof Coating/ Dr. FIXIT NEW COAT . All as per manufacturers recommendations / standard specifications and instructions of Engineer-in-charge. Rate quoted includes cost of all materials , labour charges, conveyance, tools and other incidental charges etc.complete but excluding cost of cement which will be issued free of cost at BHEL stores. (CEMENT CONSUMPTION=0.4 Kg/RM) .</p>	RM	262.20
1547	<p>Providing aluminum Sheet Flashing. The scope of work includes cutting a neat groove along the brick wall and fixing Aluminum sheet flashing of 1' to 1'6" as required including re-filling the grooves and sealing the joints with CERA SEAL / TEC POLYSEAL G /Sika Polysulphide/NACC poly seal gun grade polysulphide sealant/Dr. FIXIT PU SEALANT.All as per Manufacturer's recommendations / standard specifications and instructions of Engineer-in-Charge. Rate quoted includes cost of all materials , labour charges , conveyance, tools and other incidental charges etc.complete.</p>	RM	479.80