

TENDER DETAILS

<i>ENQUIRY No.</i>	2002200016	<i>ENQUIRY DATE</i>	18.05.2022
<i>DESCRIPTION</i>	<i>5FO Oxygen Gas Sensor-CiTiceL A5F Carbon monoxide Gas Sensor-CiTiceL, 5NF Nitric oxide Gas Sensor-CiTiceL, 5SF/F Sulphur dioxide Gas Sensor-CiTiceL</i>	<i>DUE DATE</i>	28.05.2022

Item Sl. No.	Description	Unit	Quantity
10	5FO Oxygen Gas Sensor-CiTiceL Specification for 5FO Oxygen gas Sensor (O2) Operating principle: Electrochemical Make: CiTiceL Model: 5FO Measurement range: 0-25% vol. O2 Refer annexure for photograph and contour of 5FO Oxygen (O2) gas Sensor - CiTiceL.	Nos	15
20	A5F Carbon monoxide Gas Sensor-CiTiceL Specification for A5F Carbon monoxide gas Sensor (CO) Operating principle: 4-Electrode electrochemical Make: CiTiceL Model: A5F Nominal range: 0 to 2000 ppm Refer annexure for photograph and contour of A5F Carbon Monoxide (CO) Gas Sensor - CiTiceL	Nos	5
30	5NF Nitric oxide Gas Sensor-CiTiceL Specification for 5NF Nitric oxide gas Sensor (NO) Operating principle: 4-Electrode electrochemical Make: CiTiceL Model: 5NF Measurement range: 0 to 1000 ppm Refer annexure for photograph and contour of 5NF Nitric oxide (NO) Gas Sensor - CiTiceL	Nos	5
40	5SF/F Sulphur dioxide Gas Sensor-CiTiceL Specification for 5SF/F Sulphur dioxide gas Sensor (SO2) Operating principle: 3-Electrode electrochemical Make: CiTiceL Model: 5SF/F Measurement range: 0 to 2000 ppm Refer annexure for photograph and contour of Sulphur dioxide (SO2) Gas Sensor - CiTiceL.	Nos	5

ATTACHMENTS:

Annexure A - Enquiry Terms and Conditions

Annexure B - Commercial Terms

"LD clause has to be confirmed without fail."

The bidder along with its associate / collaborators / sub-contractors / sub-vendors / consultants /service providers shall strictly adhere to BHEL fraud prevention policy displayed on BHEL website <http://www.bhel.com> and shall immediately bring to the notice of BHEL Management about any fraud or suspected fraud as soon as it comes to their notice

The **pre- qualification criteria and realistic delivery schedule** from the date of Purchase order are mentioned below (For Item nos. 10, 20, 30 & 40).

1. The vendor shall enclose a purchase order copy against their experience (PO date shall be on or after 01.01.2016) in the supply of similar group of products/ materials as in the Specifications.

2. Delivery Schedule- 100% Quantity shall be delivered within 90 days from the date of PO.

.

ANNEXURE

P.R.No. 130798667 date 17.05.2022

Item no. 10) Photograph & Contour of 5FO Oxygen (O2) Gas Sensor-CiTiceL

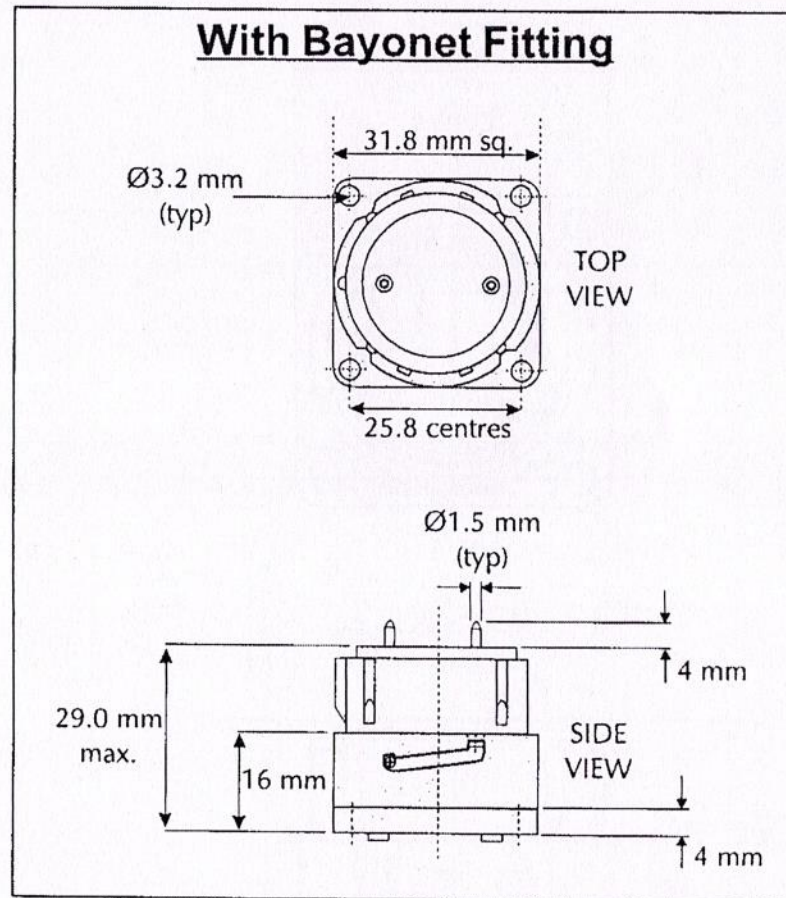
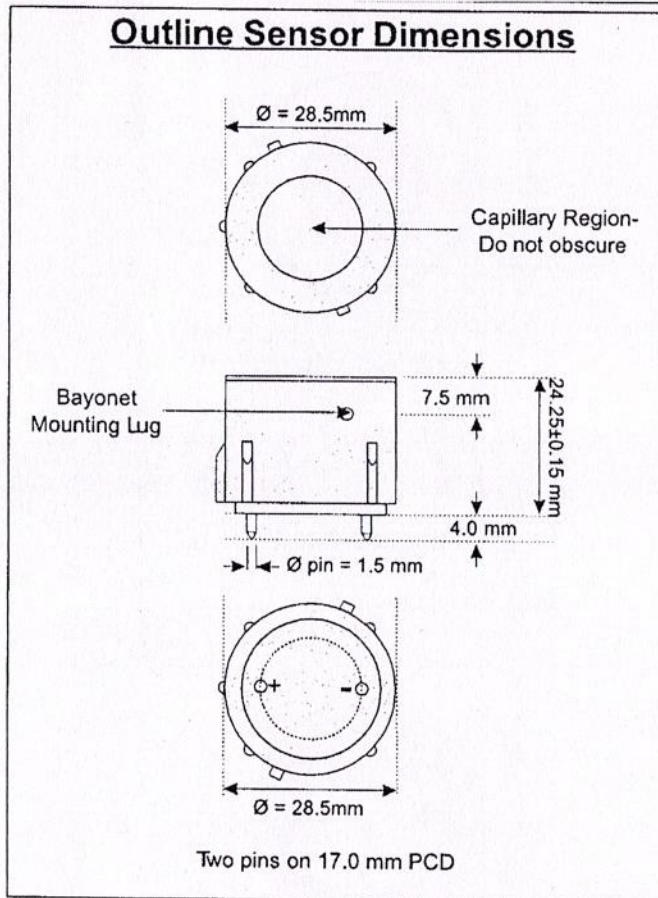

5FO Oxygen CiTiceL

A. Priyan
NIRUTHIYA PRIYAN, A
Manager
Field Engineering Services (FB)
BHEL, TRICHY - 620 014.

Item no.20) Photograph & Contour of A5F Carbon Monoxide (CO) Gas Sensor-CiTiceL

AF5 CiTiceL

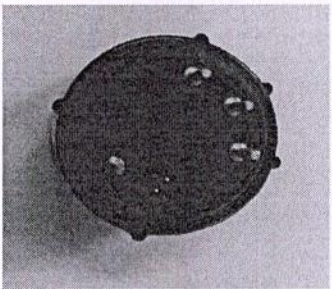
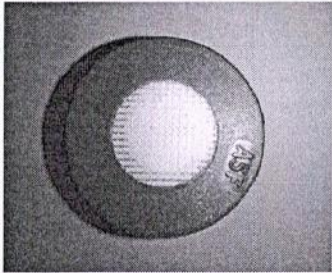

Outline Sensor Dimensions

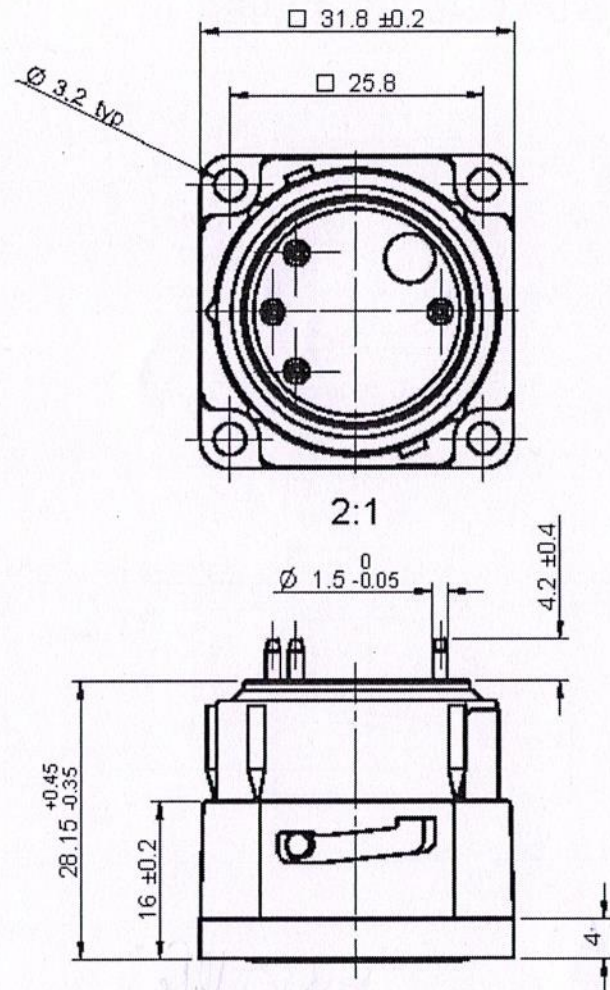

with Bayonet Fitting

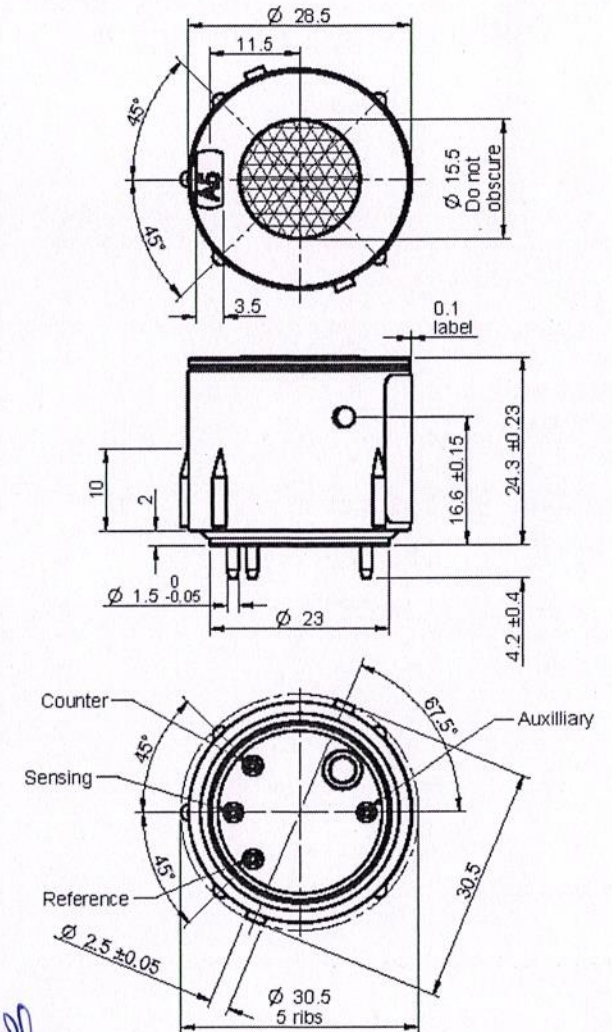

J. R. [Signature]

MIRUTHIYA PRIYAN, A
Manager
Field Engineering Services (F8)
8HEL, TRICHY - 620 011

Item no. 30) Photograph & contour of 5NF Nitric Oxide Sensor (NO) Gas Sensor-CiTiceL

5NF CiTiceL

**Product Dimensions
(without bayonet fitting)**

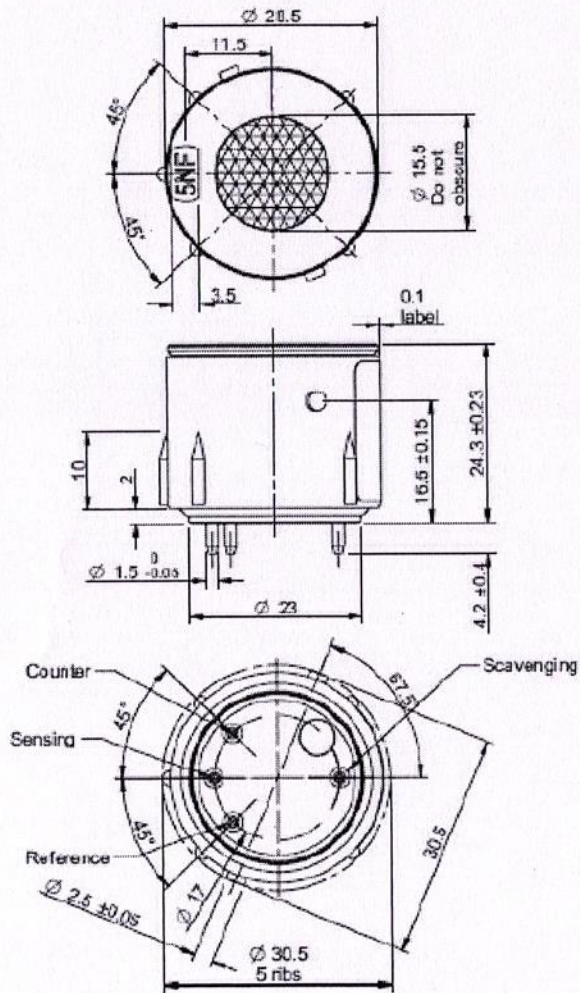

All dimensions in mm

All tolerances ±0.15 mm unless otherwise stated

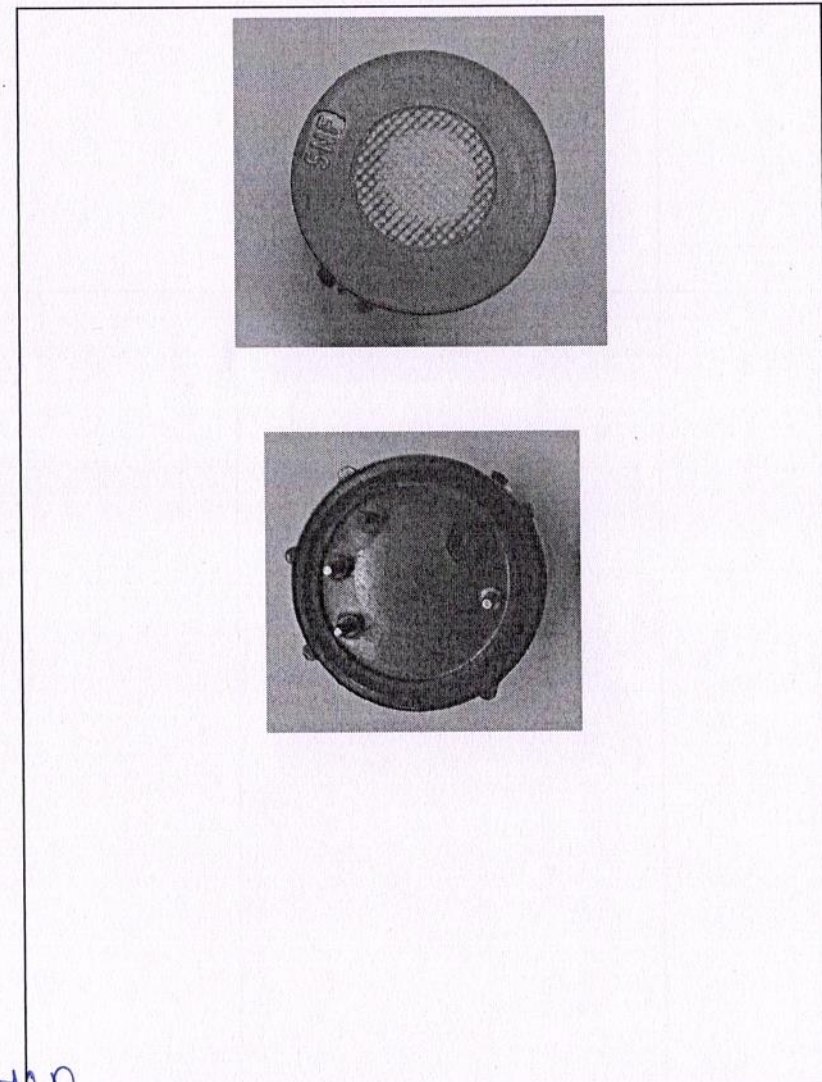

S. R. J.
ANURADHA PRIYAN, A
Manager
Field Engineering Services - FC
BHEL, TRICENT - 500 014.

P.R.No. 130798667 date 17.05.2022

Item no. 40) Photograph & Contour of 5SF/F Sulphur Dioxide (SO₂) Gas Sensor-CiTiceL

5SF F CiTiceL

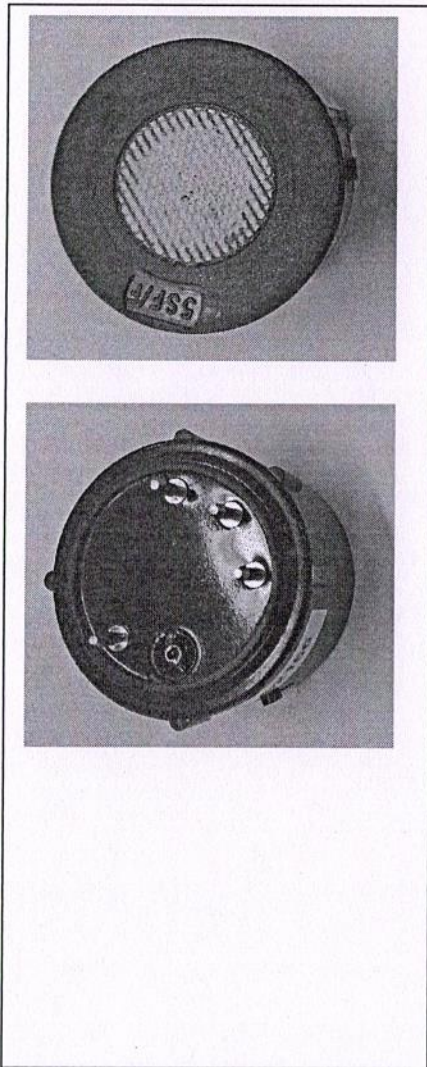

**Product Dimensions
(without bayonet fitting)**

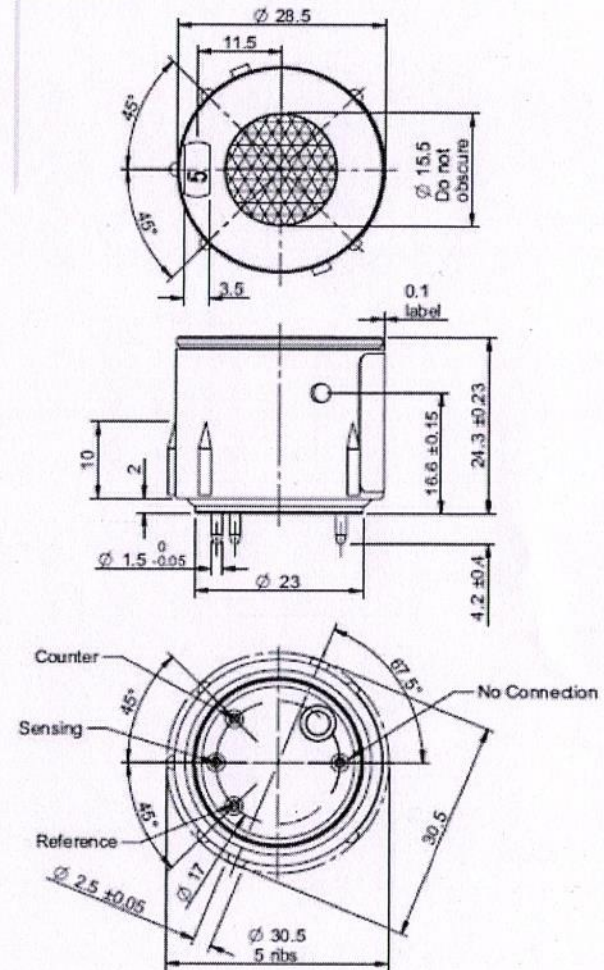

All dimensions in mm
All tolerances ±0.15 mm unless otherwise stated

MIRUTHYA PRIYAN. A
Manager
Field Engineering Services (FB)
#MEL, TRICHY - 620 014.

BHARAT HEAVEY ELECTRICALS LIMITED
TIRUCHIRAPPALLI - 620 014

ANNEXURE A - TERMS AND CONDITIONS OF THE ENQUIRY (TWO PART BID)

QUOTATIONS:

1.
 - a. Interested bidders shall submit their offer through e-Procurement mode at <https://eprocurebhel.co.in>. Offers in any other mode will not be accepted.
 - b. Bidders are requested to quote their offer price on F.O.R Destination (BHEL/Stores) basis only (The basic price of the material quoted in the bid should be inclusive of Packing, Forwarding, freight and transit insurance, etc.). Ex-works offers will be summarily rejected without further clarification.
 - c. No charges shall be indicated as “Lumpsum” or “Approximate” in absolute value. All charges like taxes and duties should be clearly specified as “percentage” of the quoted rates.
 - d. Manufacturer’s name, trademark or patent no. if any should be specified. Illustrative leaflets giving technical particulars are required along with quotation wherever necessary.
 - e. Products with I.S.I. certification marks will be preferred.
 - f. The Purchaser shall be under no obligation to accept the lowest or any other tender and shall be entitled to accept in Part or full without assigning any reason whatsoever.
 - g. The bidder has to keep track of any changes by viewing the addendum / Corrigendum's issued by the Purchaser on time-to- time basis in the E-Procurement platform. The Company calling for tenders shall not be responsible for any claims/problems arising out of this.
 - h. The user should complete all the processes and steps required for bid submission. The successful bid submission can be ascertained once acknowledgement is given by the system through bid submission number after completing all the processes and steps. BHEL and M/s. National Informatics Centre will not be responsible for incomplete bid submission by users. Users may also note that the incomplete bids will not be saved by the system and are not available for the Purchaser for processing.
 - i. Before uploading scanned documents if any, the bidders shall sign on all the statements, documents, certificates uploaded by him, owning responsibility for their correctness / authenticity.
 2. Offers should have a validity of minimum 90 days from the date of technical bid opening. The quoted/Finalized rates shall be Firm till completion of the supplies including amendment / deviation / extension if any in quantity / date.
 3. On the due date of tender opening, both technical and price bids will be opened. Offers not meeting the required specification and technical condition will be summarily rejected. If any difference is found in the terms in the Techno-commercial bid and price bid, the terms mentioned in the Techno-Commercial Bid will be considered.
 4. Ranking L-1, L-2 etc. shall be done for individual items for the techno-commercially acceptable offers on landed cost to BHEL, Trichy basis and BHEL reserves the right to place order for individual items with different vendors. In the event of more than one vendor becoming L1 for the item, revised offer will be obtained to arrive at single L1 vendor.
 5. BHEL reserves the right to negotiate with L1 vendor or re-float the tender for items where, L1 price is not the lowest acceptable price; BHEL reserves the right to increase or decrease the tender quantity.
 - 1 Tender will be opened on the due date as mentioned in the enquiry. If the due date falls on holiday, the tender document will be opened immediately on the next working day.
 - 2 Quoted price/rate should be valid for minimum of 90 days from the date of technical bid opening. The quoted/Finalized rates shall be Firm till the completion of the supplies.
 - 3 The rates are to be quoted on F.O.R. destination basis only. It should be inclusive of Packing& Forwarding and Freight& Insurance. Other delivery conditions like Ex-works / Ex-Godown will be summarily rejected.
 - 4 Offers should be free from CORRECTION and ERASURES.
 - a. Corrections if any must be attested;
 - b. All amounts shall be indicated both in words as well as in figures.
 - c. If there is difference between amount quoted in words and figures, amount quoted in words shall only be considered.
 - d. If, in the price structure quoted for the required goods/services/works, there is discrepancy between the unit price and the total price (which is obtained by multiplying the unit price with the quantity),
-

the unit price shall prevail and the total price will be corrected accordingly, unless in the opinion of the purchaser that there is an obvious misplacement of the decimal point in the unit price, in which case the total price as quoted shall govern and the unit price will be corrected accordingly.

- e. If there is an error in a total corresponding to the addition or subtraction of subtotals, the subtotals shall prevail and the total shall be corrected accordingly.
- f. If there is a discrepancy between words and figures, the amount in words shall prevail, unless the amount expressed in words is related to an arithmetic error, in which case the amount in figures shall prevail subject of (d) and (e) above.

5 No revision of prices will be entertained after enquiry is opened.

6 **Payment Terms (Indigenous):**

Payment term is 100% direct payment within 90 days from date of receipt and acceptance of materials. For Micro and Small Enterprises Payment within 45 days from date of receipt and acceptance of materials. For Medium Enterprises Payment within 60 days from date of receipt and acceptance of materials. Payments for MSE Indigenous vendors will be as MSMED Act, 2006.

7 **Liquidated Damages / Penalty:**

(Any deviations in the LD shall attract loading to the extent of relaxation sought to which it is not agreed by the bidder at offered value).

Single delivery schedule:

If the Supplier fails to deliver the P.O quantity within the period specified in the contract, then the Purchaser shall deduct liquidated damages, 0.5% of the total order value per week of delay or part thereof subject to a maximum of 10% of the total order value.

8 **RISK PURCHASE:**

Alternatively, the purchaser at his option will be entitled to terminate the contract and to purchase elsewhere at the risk and cost of the seller either the whole of the goods or any part which the supplier has failed to deliver or dispatch within the time stipulated as aforesaid or if the same were not available, the best and the nearest available substitutes therefore. The supplier shall be liable for any loss, which the purchaser may sustain by reason of such risk purchases in addition to penalty at the rate mentioned in our LD clause.

a) In the event of any successful Tenderer's failure to fulfil any of the tender / Contract obligations as per Contract / Agreement, BHEL may purchase from the alternate vendor and get it completed to meet the BHEL requirement and additional expenditure, if any, including consequential cost viz., demurrage etc., will be fully recovered from the supplier who failed to supply the items with the due date.

b) The decision of BHEL with regard to the actual losses / consequential expenditure incurred by BHEL shall be final and binding on the supplier.

The value under Risk purchase clause shall be calculated as follows:

$Risk \ \& \ Cost \ Amount = [(A-B) + (A \times H/100)]$

Where,

A= Value of Balance scope of Work/ Supply (*) as per rates of new contract

B= Value of Balance scope of Work/ Supply (*) as per rates of old contract being paid to the contractor/ supplier at the time of termination of contract i.e. inclusive of PVC & ORC, if any.

H = Overhead Factor shall be taken as 5

In case (A-B) is less than 0 (zero), value of (A-B) shall be taken as 0 (zero).

*(Balance scope of work/ supply)

Difference of Tendered/Contract Quantities and Executed Quantities as on the date of issue of Letter for 'Termination of PO/Contract', shall be taken as balance scope of Supply for calculating risk & cost amount.

9 **GST:**

Tender terms for GST in line with new GST Return System: (Effective from 01.10.2019)

For supplies after implementation of New GST Return System i.e. from 01/10/2019, the following conditions will apply and supplier shall fully comply to the below points.

Indigenous suppliers:

- a) Response to Tenders for Indigenous supplier will be entertained only if the vendor has a valid GST registration Number (GSTIN) which should be clearly mentioned in the offer. If the dealer is exempted from GST registration, a declaration with due supporting documents need to be furnished for considering the offer. Dealers under composition scheme should declare that he is a composition dealer supported by the screen shot taken from GSTN portal. The unregistered dealer as well as the composition dealer has to submit an undertaking stating that they will not claim GST during the execution of the contract even if their status under GST changes to regular tax payer. The dealer has to submit necessary documents if there is any change in status under GST.
- b) Supplier shall mention their GSTIN in all their invoices (incl. credit Notes, Debit Notes) and invoices shall be in the format as specified/prescribed under GST laws. Invoices shall necessarily contain Invoice number (in case of multiple numbering system is being followed for billing like SAP invoice no, commercial invoice no etc., then the Invoice No. which is linked/uploaded in GSTN network shall be clearly indicated), Billed to party (with GSTIN) & Shipped to party details, item description as per PO, Quantity, Rate, Value, applicable taxes with nomenclature (like IGST, SGST, CGST & UTGST) separately, HSN/ SAC Code, Place of Supply etc. Wherever E-Invoice is applicable, the tax invoice/ CN / DN submitted by the vendor must contain the QR code generated in E-Invoice Portal & IRN.
- c) All invoices shall bear the HSN Code for each item separately (Harmonized System of Nomenclature)/ SAC code (Services Accounting Code)
- d) Invoices will be processed only upon completion of statutory requirement and further subject to following:
- i. Vendor declaring such invoice in their GSTR-1 Return/ IFF
 - ii. Receipt of Goods or Services and Tax invoice by BHEL
- e) As the continuous uploading of tax invoices in GSTN portal (in GSTR-1/ IFF) is available for all (i.e. both Small & Large) tax payers, all invoices raised on BHEL may be uploaded immediately in GST portal on dispatch of material /rendering of services. The supplier shall ensure availability of Invoice in GSTN portal before submission of invoice to BHEL. Invoices will be admitted by BHEL only if the invoices are available in GSTN portal (in BHEL's GSTR-2A/ GSTR-2B).
- f) In case of discrepancy in the data uploaded by the supplier in the GSTN portal or in case of any shortages or rejection in the supply, then BHEL will not be able to avail the tax credit and will notify the supplier of the same. Supplier has to rectify the data discrepancy in the GSTN portal or issue credit note or debit note (details also to be uploaded in GSTN portal) for the shortages or rejections in the supplies or additional claims, within the calendar month informed by BHEL.
- g) In cases where invoice details have been uploaded by the vendor but failed to remit the GST amount to GST Department (Form PMT-08 or Form GST RET-01 to be submitted) within stipulated time, then GST paid on the invoices pertaining to the month for which GST return not filed by the vendor will be recovered from the vendor along with the applicable interest (currently 24% p.a) and all subsequent bills of the vendor will not be processed till filing of the GST return by the vendor.
- h) In case GST credit is denied to BHEL due to non-receipt or delayed receipt of goods and/ or tax invoice or expiry of timeline prescribed in GST law for availing such ITC, or any other reasons not attributable to BHEL, GST amount claimed in the invoice shall be disallowed to the vendor.
- i) Where any GST liability arising on BHEL under Reverse Charge (RCM), the vendor has to submit the invoices to BHEL well within the timeline prescribed in GST Law, to enable BHEL to discharge the GST liability. If there is a delay in submission of invoice by the vendor resulting in delayed payment of GST by BHEL along with Interest, then such Interest payable or paid shall be recovered from the vendor.
-

j) Under GST regime, BHEL has to discharge GST liability on LD recovered from suppliers/contracts. Hence applicable GST shall also be recoverable from suppliers/contractors on LD amount. For this Tax Invoice will be issued by BHEL indicating the respective supply invoice number.

k) GST TDS will be deducted as per Section 51 of CGST Act 2017 and in line with Notification 50/2018 –Central Tax dated 13.09.2018. GST TDS certificate will be generated in GSTN portal subsequent to vendor accepting the TDS deduction in the GSTN portal & the vendor can directly download the Certificate from the GSTN Portal.

10 Special Provisions for Micro and Small Enterprises (MSE) bidders registered as per MSME act:

i. As per Gazette Notification no. S.O. 2119(E) dated 26.06.2020 issued by Ministry of MSME applicable/existing Micro and small suppliers are requested to get registered with Udyam Registration portal and share us the Udyam registration no along with Udyam registration certificate. Payments for MSE Indigenous vendors will be as MSMED Act, 2006.

ii. 25% of the tendered quantity is earmarked for MSE Vendors (Manufacturers only and not for the Traders/Dealers of Service Category - Vide Office Memorandum circular of Micro, Small & Medium Enterprises, Clause – i, dt: 09.02.17) in this tender. If L1 offer is from a Micro / Small enterprise, this provision is not applicable.

iii. Out of the 25% tendered quantity reserved for MSE suppliers, 6.25% shall be earmarked for procurement from MSE owned by SC / ST entrepreneurs. In event of failure of such Micro and Small enterprises to participate in the tender process or meet the tender requirements and the L1 price, the 6.25% sub-target for procurement earmarked MSE owned by SC / ST entrepreneurs shall be met with other MSE enterprise/s.

iv. Out of the 25% tendered quantity reserved for MSE suppliers, 3% shall be earmarked for procurement from MSE owned by women entrepreneurs. In event of failure of such Micro and Small enterprises to participate in the tender process or meet the tender requirements and the L1 price, the 3% sub-target for procurement ear-marked MSE owned by women entrepreneurs shall be met with other MSE enterprise/s.

v. In case MSE vendor participating in the tender quotes within the price band of L1 + 15%, they will be allowed to supply the portion of the requirement subject to acceptance of L1 price by MSE vendor. In case of more than one such MSE, the supply shall be shared proportionately.

MSE suppliers can avail the intended benefits only if they submit Udyam registration certificate along with the Offer.

This provision for MSE will apply subject to the condition that the participating MSE meets the tender requirements.

vi. In case of any change in the MSE status of the bidder, it shall be the responsibility of the bidder to notify the change as a part of the bid document. If at a later date it comes to the knowledge of BHEL, that the change in the status has not been intimated by the bidder and the order is obtained under the premise of an MSE then BHEL would cancel the pending order against this tender and take necessary steps for suspension of the business dealing with the bidder as per the procurement policy of BHEL.

vii. In case after the bid opening it is seen that no MSE has become L1, then depending on the nature of the item, if it is not possible to split the tendered items / quantities on account of reasons like customer contract requirements of supplying one make for a given project or technical reasons like tendered items being a system etc., and in case MSE vendor participating in the tender quotes within the price band of L1 + 15%, they will be allowed to supply the entire quantity subject to acceptance of L1 price by MSE vendor. Counter offer for entire quantity will be made in the order of commercial ranking of the MSE vendors within the price band of L1 + 15%.

In case of counter offering rate has not been accepted by MSE vendors or L1 vendor is MSE, entire quantity will be ordered on L1 vendor.

11 Lowest price received against BHEL enquiry need not be the technically acceptable one and in that case BHEL reserves the rights to not to consider the same. The purchaser shall be under no obligation to accept the lowest or any other offer and shall be entitled to accept or reject any offer in part or full without assigning any reason whatsoever.

12 BHEL reserves the right to negotiate or re-float the enquiry opened if L1 price is not the lowest acceptable price to them inter-alia other reasons.

13 Any other conditions which might have been quoted by the seller and are in contravention to the terms and prescribed in the enquiry and which have not been specifically accepted by purchaser will not be applicable to the contract.

14 Any corrigendum related to the enquiry will be hosted in the BHEL website only, Bidders should visit the website(s) to keep themselves updated.

15 The correspondence between the bidder and BHEL through email is considered as valid document legally though it is not signed. It is treated as valid confirmations made on behalf of the respective company and comes under the legal ambit of the business transaction and hence binding on both the parties.

16 Disclaimer Clause: Neither the Organization (Bharat Heavy Electricals Ltd.) nor the service provider (M/s. National Informatics Centre) is responsible for any failure of submission of bids due to failure of internet or other connectivity problems or reasons thereof.

17 Bidders participating in the enquiry should declare in their technical bid whether they have been black-listed / kept on hold / given Business holiday for a specified period by any Public Sector Undertaking or Government Departments. The reasons for such action with complete details and the current status of such hold shall be clearly furnished to BHEL. If no such details are mentioned in the offer, it will be construed that the bidder is not under any such hold.

However, at a later date if it comes to the notice of BHEL about any such hold under enforcement, BHEL reserves the right to reject the offer at any point of time and also at any stage of the finalization of the enquiry. Such bidders will not be permitted to participate in the further enquiry proceedings and will be communicated suitably.

18 Bidders not confirming to the enquiry specifications will be disqualified.

19 Conditional offers will be rejected.

20 PACKING AND MARKING:

The supplier shall arrange for securely protecting and packing the stores to avoid loss or damages during transit.

21 In case of any quality rejection of materials, the supplier has to collect the materials at his own cost within the 10 days of rejection of advice. Otherwise the materials will be scrapped.

22 Unloading at BHEL has to be done by the suppliers and BHEL will not be in a position to provide any handling / unloading facilities.

**COMMERCIAL TERMS CONFIRMATION REQUIRED FROM THE SUPPLIERS
TO BE SUBMITTED ALONG WITH PART – I (TECHNO COMMERCIAL BID)
ANNEXURE – B**

S. NO	DESCRIPTION	BHEL REQUIREMENTS	SUPPLIER CONFIRMATION / DEVIATION (STRIKEOUT WHICHEVER IS NOT APPLICABLE)
1	VALIDITY	90 DAYS FROM DATE OF TECHNICAL BID OPENING	NON DEVIATABLE
2	PRICE QUOTED	FOR DESTINATION BHEL TRICHY STORES-WARD 16	NON DEVIATABLE
3	GST DETAILS	CGST	INCLUSIVE / EXTRA _____ %
		SGST	INCLUSIVE / EXTRA _____ %
		IGST	INCLUSIVE / EXTRA _____ %
4	DELIVERY SCHEDULE	within 90 days from the date of PO.	
5	PAYMENT TERMS	As per S.No:6 of Terms and conditions of the Annexure-A of Enquiry	NON DEVIATABLE
6	LD CLAUSE	0.5% of the total order value per week of delay or part thereof subject to a maximum of 10% of the total order value (For details please read S.No:7 of Terms and conditions of the Annexure-A of Enquiry)	NON DEVIATABLE
7	RISK PURCHASE CLAUSE	For details please read S.No:8 of Terms and conditions of the Annexure-A of Enquiry	NON DEVIATABLE
8	PRICE VARIATION	NO PRICE REVISION SHALL BE ENTERTAINED TILL COMPLETION OF ORDERED QUANTITY INCLUDING EXTENSION / VARIATION IF ANY.	NON DEVIATABLE
9	CONTACT PERSON DETAILS	NAME: MOBILE NO: EMAIL :	To be filled compulsorily
10	Supply of Gas sensors CiTiceL - 5FO Oxygen (O2), A5F Carbon monoxide (CO), 5NF Nitric oxide (NO) & 5SF/F Sulphur dioxide (SO2) as per specification given in the enquiry		CONFIRM / NOT CONFIRM
11	Udyam Registration Certificate in case of MSME vendor		ATTACHED/ NOT ATTACHED
12	<i>Bidders have to confirm that, whether they have been black-listed / kept on hold / given Business holiday for a specified period by any Public Sector Undertaking or Government Departments/any other units of BHEL.</i>		YES / NO

Note: Please strike out whichever is not applicable

SIGN AND SEAL OF THE AUTHORIZED
PERSON TO SIGN THE TENDER DOCUMENT