

Bharat Heavy Electricals Limited

Heavy Plates & Vessels Plant

Visakhapatnam – 530 012

Andhra Pradesh, INDIA

PAN - AAACB4146P, GST - 37AAACB4146P7Z8



Tel. : +91(0) 891 288 1332 / 1358 / 1359

E-mail : yvrrao@bhel.in
dnmurthy@bhel.in
nd@bhel.in

INVITATION TO TENDER

Ref: OS/22-23/R&D/5603/07/007

Date: 16.06.2022

Sub: Manufacturing of Welding Fixture Components (SS) for Heat Exchangers of Su-30 Mk-1 Aircraft against S.O. No. 5603 at Vendor's works with free issue materials

Dear Sir,

Sealed tenders are invited for the subject job in **two-part bid** system from the **Vendors** who are experienced in execution of similar jobs subject to the following eligibility criteria:

- (1) Bidder must have an experience in successful execution of similar jobs with strict dimensional compliance i.e. CNC Machining, Milling, Turning, Drilling, Precision Pressing, Surface Grinding etc., for Customers like ADA, BDL, DRDO, HAL, DARE, ISRO etc. during the past 7 Years as on 31.05.2022. Bidders shall enclose Work Order, Work Completion Certificate and all other relevant documents in support of their experience in execution of similar jobs for at least one project.
- (2) Bidder shall also have to enclose the documents of Registration of Firm/ Certificate of Incorporation/ Factory License, Udyog Aadhar Memorandum/ Udyam Registration (if registered with MSME), PAN & GSTIN Registration.
- (3) The works executed in own name of the individual / firm of the tenderer will only be considered for eligibility criteria.

1. **LOCATION OF WORK SPOT:**

The subject work is to be carried out at **Vendor's Works**.

2. **VENDOR'S SCOPE OF WORK:**

- a) Manufacturing of Welding Fixture Components (SS) for Heat Exchangers of Su-30 Mk-1 Aircraft which involves CNC Cutting, Machining, Drilling, Milling, Surface Grinding, Trial Assembly etc., with SS Plate & Rod as free issue materials as per the drawings listed in Annexure-II, applicable standards & specifications. Details of the components to be manufactured are given in the Annexure – II. **Allen Headed Screws, Nuts & Locating Pins shall be supplied by the Vendor at their cost.**
- b) All the manufactured components shall conform to the dimension/standards mentioned in respective drawings.
- c) Flatness / Tolerance (Angular/Linear/Positional) / Surface Finish to be maintained as per the drawings. All sharp corners to be rounded off.
- d) The manufactured components shall be free from burrs and surface marks.
- e) Dimensions and Run outs to be ensured by tools.
- f) Tolerances indicated are non-cumulative.
- g) After trial assembly and inspection clearance, the components shall be dismantled and handed over separately to R&D dept., HPVP – Visakhapatnam.
- h) All required tools are in the scope of Vendor.
- i) Bidders shall have requisite facilities like CNC Drilling, Milling, Pressing, Surface Grinding Machines etc., for machining & processing of high precision jobs.
- j) Bidders shall have Calibrated Surface Table, Digital measuring instruments like Vernier Calipers, Height Gauges, Go - No Go Thread Gauges, Radius Gauges etc. required for inspection of finished components.
- k) The finished components shall be securely packed in suitable lots and are to be delivered by the vendor to Sr.Manager (R&D), BHEL-HPVP, Visakhapatnam on door delivery basis.
- l) Any modification work due to revision of drawings during manufacturing is to be carried out by the vendor without any extra cost. Though not mentioned specifically, any activity which is required for completion of the work is deemed to be included in the scope of work of vendor.

Contd...2

3. TRANSPORTATION:

Collection & Transportation of free issue raw materials from HPVP, Visakhapatnam to Vendor's works and Transportation of Finished Items from Vendor's works to R&D Dept., BHEL – HPVP, Visakhapatnam is in Vendor's scope.

4. BHEL's SCOPE:

The following shall be provided by BHEL:

- a) Issue of applicable Drawings & reference Documents
- b) Issue of Stainless Steel Plate & Rod as Free issue raw materials at BHEL - HPVP, Visakhapatnam
- c) Equipment details will be engraved by BHEL

5. INSPECTION:

Inspection shall be carried out at Vendor works by M/s BHEL - HPVP (QC) and / or by an appointed agency / Customers. Instruments required for inspection of finished components are to be arranged by the vendor along with calibration certificates. All the documentation related to inspection such as BHEL / TPI / Customer Clearance, Generation of Inspection Reports, Preparation of Final Documents as per BHEL standard formats etc., is in the scope of vendor and soft copy as well as hard copy of the same are to be submitted to BHEL-QA.

6. DELIVERY:

Finished components along with relevant inspection documents and all other certificates are to be delivered Within **4 weeks** to Sr. Manager (R&D), BHEL-HPVP, Visakhapatnam.

The delivery period will be calculated from the date of issue of materials at BHEL-HPVP, Visakhapatnam to the date of receipt of finished items at BHEL-HPVP, Visakhapatnam.

Note:

- a) In case the delivery period offered by the vendor is more than the tender delivery, Price quoted by the bidder shall be loaded for additional period @1/2 % per week or part thereof for the purpose of evaluation of Bidder Status.
- b) Free issue materials shall be collected within 2 days from the date of intimation by R&D / Outsourcing dept. without any failure. Any delay beyond 2 days shall be considered for levy of LD.

7. PRICE:

The prices shall be quoted as per **Annexure – I** for the detailed scope of work mentioned in the tender document. The quoted price shall be inclusive of all applicable taxes & duties **except GST** and Income tax shall be deducted at applicable rates from the vendor's bills. GST shall be reimbursable to the vendor as per applicable guidelines.

The prices shall be fixed & firm without any escalation during the entire period of contract and till completion of the work.

8. GOODS & SERVICES TAX (GST):

Bidders shall make a note of the following points of GST before submission of their offer:

- a) Vendors registered under GST Act shall have to mention their GSTIN no. (15 Digits) in their Technical Bid. If any specific exemption is available, a declaration with due supporting documents need to be furnished for considering their offer.
- b) Semi-finished goods are to be delivered by the Vendors in BHEL, HPVP premises within a maximum period of one year from the date of issue of the material, failing which the whole transaction will be considered as Supply and Sale and GST is required to be paid along with interest (calculated @ SBI Base Rate + 6%) along with penalty, if any, from the date of Challan on the whole value of materials. Hence vendors shall have to ensure that materials issued to them are returned within 365 days.

- c) After fabrication, the vendors shall have to deliver the Semi-Finished Goods by fulfilling the following formalities:
 - i) GST invoice should be raised by the vendors by paying GST on job work charges at applicable rates and by incorporating the HPVP GSTIN no. in the invoice for availing the reimbursement of GST from HPVP.
 - ii) The vendor shall also have to enter in their GST Return -1 (GSTR-1) the details of invoice raised for payment of GST so as to enable HPVP to avail input credit.

9. REVERSE AUCTION:

BHEL shall be resorting to Reverse Auction (RA) for this tender. RA shall be conducted among all the eligible techno-commercially qualified bidders. Business Rules for Reverse Auction are given at Annexure-V and Guidelines for Reverse Auction are available on our website, www.bhel.com → supplier registration → Guidelines for Reverse Auction 2021, before submission of their offer.

Sealed envelope / Electronic Price bids of all the techno-commercially qualified bidders shall be opened and the same shall be considered as initial bids of the bidders in RA. In case any bidder(s) do(es) not participate in online Reverse Auction, their sealed envelope / Electronic price bid along with applicable loading, if any, shall be considered for ranking.

BHEL will inform bidders the details of service provider who will provide business rules, all necessary training and assistance before commencement of online bidding. The bidders participating in the Reverse Auction shall have to necessarily submit '**Process Compliance Form**' (PCF) to the designated Service Provider.

Bidders are advised to read the 'Business Rules' (Annexure – V) indicating details of RA event carefully, before reverse auction event.

10. VALIDITY OF OFFER:

The offer shall be valid for a period of **3 months** from the date of reverse auction.

11. RISK PURCHASE:

In case the vendor fails to execute the work within the scheduled time or due to any other reasons, BHEL-HPVP reserves the right to get the same completed through some other vendors at the risk & cost of the vendor and any additional expenditure incurred due to the same shall be charged to the vendor's account.

12. General Terms & Conditions, whichever applicable, shall be as per Annexure-III enclosed.

13. GENERAL:

- a) The bidders shall study the Tender documents, Drawings, Quality Documents and all other relevant documents in detail for understanding the scope of work and the processes involved before submission of offer. Bidders shall get clarifications, if any, from concerned officials on the scope of work, clarifications related to welding or any other details of the tender document, over phone between 09:00 AM and 04:00 PM on any working day or through e-mail.
- b) Drawings, QAP, Clarifications related to Welding, other reference documents etc., shall be sent to the bidder's e-mail address upon their written/e-mail request.
- c) **Conditional / Partial Price Bids** and any other deviations to the tender terms & conditions are not acceptable and BHEL reserves the right to reject such offers without further correspondence. Bidders shall confirm their acceptance to all the terms & conditions of the tender enquiry in the Techno-commercial Bids and any deviations mentioned in the Price Bids shall not be considered.
- d) BHEL reserves the right to modify or cancel the tender enquiry at any stage without assigning any reasons thereof.
- e) The General Terms & Conditions, if any, contradicting with the specific terms & conditions given in the tender, then specific terms & conditions shall only be considered.

14. The following documents shall form part of the tender enquiry:

- | | |
|--|------------------|
| a) Schedule of Rates | : Annexure - I |
| b) Details of items & applicable drawings | : Annexure – II |
| c) General Terms & Conditions | : Annexure - III |
| d) Acceptance to Tender terms & conditions | : Annexure – IV |
| e) Business Rules for Reverse Auction | : Annexure - V |
| f) GST Compliance for Indigenous Suppliers | : Annexure – GST |
| g) Reference Drawings | |

15. **TENDER SUBMISSION (through E-mail only):**

Techno-commercial bids along with the tender document duly signed & stamped by the bidder on all pages and a covering letter on Company's Letter Head addressed to DGM (Outsourcing), BHEL –HPVP, Visakhapatnam shall be sent through an e-mail to the e-mail ID technicalbid-hpvp@bhel.in

Price bid (Annexure-I) shall be sent separately through e-mail to another e-mail ID pricebid-hpvp@bhel.in

Offers completed in all respects along with all the supporting documents shall be sent to the above e-mails only **latest by 14.00 Hrs. on 23.06.2022** duly mentioning the Name of Work, Tender Ref. No. & Date and Technical Bid / Price Bid in the subject of the e-mail.

Note: Don't mark CC and BCC while submitting your offer as the system is designed to reject such mails having more than one recipient. Max. file size of the attachment shall be 20 MB only. In case the file size is more, bidder can submit their offer through multiple mails within the due date and time.

Bidders shall ensure correctness of the e-mail addresses while submitting their offer. There shall be no other e-mail address at the receiving end while submission of the above bids otherwise the system will reject such mails. Bidder shall be solely responsible for non-receiving of such mails at the above mentioned e-mail addresses and no communication in this regard will be entertained.

TENDERS RECEIVED AFTER THE DUE DATE & TIME ARE NOT ACCEPTABLE.

OFFERS SENT IN ANY OTHER FORM WILL BE TREATED AS INVALID AND WILL BE SUMMARILY REJECTED.

16. **TENDER OPENING:**

Techno-commercial Bids will be opened **at 14.00 Hrs. on 23.06.2022**. The bidders may depute their representatives at the time of opening of techno- commercial bids.

After evaluation of the techno-commercial Bids, intimation regarding date & procedure of conducting reverse auction shall be given by the service provider to all the eligible techno-commercially qualified bidders through an e-mail in advance at an appropriate time.

For Bharat Heavy Electricals Limited,

16/06/2022
D. N. MURTHY
Dy. Manager (OS)
Bharat Heavy Electricals Ltd
HPVP, Visakhapatnam-530 011

Schedule of Rates

Tender Enquiry Ref: OS/22-23/R&D/5603/07/007 dated 16.06.2022

Sub: Manufacturing of Welding Fixture Components (SS) for Heat Exchangers of Su-30 Mk-1 Aircraft against S.O. No. 5603 at Vendor's works with free issue materials

Sl. No.	S.O. No.	Part No.	Description of Work	Unit	Qty.	Unit Rate (Rs.)	Amount (Rs.)
			Manufacturing of Welding Fixture Components (SS) for Heat Exchangers of Su-30 Mk-1 Aircraft which involves CNC Cutting, Machining, Milling, Drilling, Precision Pressing, Grinding etc., with SS Plate & Rod as free issue raw materials as per the drawings listed in Annexure-II and as per the detailed scope of work mentioned in the tender.				
Item 1 - Welding Fixture Components (SS)							
1.1	5603	1	Top Counter Flange	No.	1		
1.2		2	Bottom Counter Flange	No.	1		
1.3		3	Support - 1	No.	8		
1.4		4	Bolting Plate Top	No.	2		
1.5		5	Ferrule Cover - 1	No.	2		
1.6		6	Clamping Plate - 1	No.	1		
1.7		7	Clamping Studs - 1	No.	6		
1.8		9	Stiffener	No.	2		
1.9		10	Stiffener - 1	No.	2		
				TOTAL		25	
Total Amount (in Words): Rupees _____ only							

Notes:

- i) a) L1 status shall be evaluated based on the total quoted value.
b) Part quotation is not acceptable and such offers are liable for rejection.
- ii) The quantity indicated above is tentative and may vary slightly subject to the requirement at the time of ordering / execution. However, payment shall be made for the actual quantity only.
- iii) The quoted price shall be inclusive of all applicable taxes & duties **except GST** and Income tax will be deducted from Vendor's bills at applicable rates. However, GST shall be reimbursed by BHEL on submission of proof of GST payment.
- iv) The prices shall be fixed & firm without any escalation during the entire period of contract and till completion of work.
- v) The bidders are advised to go through all the drawings & documents before quoting the tender.
- vi) The evaluation currency for this tender shall be **INR**.
- vii) Tenderer should quote the amount in figures & words. It may be noted that corrections, overwriting etc. are not allowed. If there is a discrepancy between amount in figures & words, the amount in words shall prevail unless the amount expressed in words is related to an arithmetic error, in which case the amount in figures shall prevail. If there is an error in the total corresponding to the addition or subtraction of sub-totals, the sub-totals shall prevail and total shall be corrected accordingly.

In case of mismatch between rate and amount in figures, rate in figures shall be taken into consideration for further evaluation and processing.

Signature of the Bidder with Stamp

ANNEXURE - II**LIST OF ITEMS TO BE FABRICATED & APPLICABLE DRAWINGS**

Tender Enquiry Ref: OS/22-23/R&D/5603/07/007

Date: 16.06.2022

Sub: Manufacturing of Welding Fixture Components (SS) for Heat Exchangers of Su-30 Mk-1 Aircraft against S.O. No. 5603 at Vendor's works with free issue materials

Sl. No.	S.O.	Part No.	Description of Item	Drawing No. & Rev. No.	Raw Material Size & Specn.	Total Qty. (No.)
ITEM 1 - Welding Fixture Components (SS)						
1.1	5603	1	Top Counter Flange	RD-SU30-F-P-00002, Rev 0	16 mm thick SS 316/321 Plate	1
1.2		2	Bottom Counter Flange	RD-SU30-F-P-00003, Rev 0	16 mm thick SS 316/321 Plate	1
1.3		3	Support - 1	RD-SU30-F-P-00004, Rev 0	Ø 30 mm SS 316/321 Rod	8
1.4		4	Bolting Plate Top	RD-SU30-F-P-00005, Rev 0	20 mm thick SS 316/321 Plate	2
1.5		5	Ferrule Cover - 1	RD-SU30-F-P-00006, Rev 0	Ø 100 mm SS 316/321 Rod	2
1.6		6	Clamping Plate - 1	RD-SU30-F-P-00007, Rev 0	20 mm thick SS 316/321 Plate	1
1.7		7	Clamping Studs - 1	RD-SU30-F-P-00008, Rev 0	Ø 30 mm SS 316/321 Rod	6
1.8		9	Stiffener	RD-SU30-F-P-00009, Rev 0	16 mm thick SS 316/321 Plate	2
1.9		10	Stiffener - 1	RD-SU30-F-P-00010, Rev 0	16 mm thick SS 316/321 Plate	2
				TOTAL		

GENERAL TERMS & CONDITIONS**1. TECHNICAL DELIVERY CONDITIONS:**

The work should conform to the technical data given in our drawings, GMS, Shipping List Specifications, QAP, WPS etc.

2. PARTY'S SCOPE:

The scope of the party shall be as follows: -

- a) All welding equipments, baking oven, tools, jigs and fixtures, measuring instruments duly calibrated, handling facilities, testing facilities etc.
- b) All materials other than those mentioned under "Free Issue Materials", which are required for completion of the work.
- c) All consumables such as electrodes, gases, grinding wheels etc.

Note: Electrodes of specification mentioned in the drawings / WPS and of BHEL approved brands only shall be used and MTCs of the same shall be submitted to BHEL for verification before use.

3. REVISION OF DRAWINGS:

There may be minor changes in the drawings during execution. In such a case, party should accommodate the same without any extra claim.

4. WELDING QUALIFICATION: Qualification of required number of Welders is party's responsibility at their cost.**5. X-RAY:**

All welding shall be of X-ray quality where specified on drawings. Inspection would specify the quantum of X-ray based on drawings / code requirement. Party should strictly follow the WPS and QAP issued by BHEL during welding. Getting the welds radiographed and getting them cleared by inspection is the responsibility of the party.

6. RECTIFICATIONS / REJECTIONS:

Any rectification due to defective work, if required, shall be done by the party free of charge with a suitable technology approved before hand by BHEL in writing. The cost of material, if any used for rectification work / rejection work, will be estimated by BHEL and the same shall be debited to party's account. In case any rectification / rework is to be carried out due to defective material supplied by BHEL, the replacement material and consumables will be supplied by BHEL free of Cost.

7. SECURITY DEPOSIT:

Vendors shall have to submit a Bank Guarantee for **25%** of the material cost towards Security Deposit and safe custody of free issue materials within 15 days from the date of intimation by Outsourcing dept. The BG shall be valid for the entire contract period with a claim period of 12 months. This Bank Guarantee shall be released to the contractor after completion of work and on acceptance of the final bill by BHEL.

Bidder agrees to submit performance security required for execution of the contract within the time period mentioned above. In case of delay in submission of performance security, enhanced performance security which would include interest (SBI rate + 6%) for the delayed period, shall be submitted by the bidder. Further, if performance security is not submitted till such time the first bill becomes due, the amount of performance security due shall be recovered as per terms defined in NIT/contract, from the bills along with due interest.

8. PERFORMANCE BANK GUARANTEE:

Vendors shall have to submit Performance Bank Guarantee (claim period of 12 months) for 10% of the order value covering for the defects liability period. If PBG is not submitted, 10% of the order value shall be deducted towards PBG from the final bill and shall be refundable after performance guarantee period, if no defects are found during this period.

9. RAW MATERIALS ISSUE:

Raw materials shall be issued with appropriate processing allowance and invisible wastage over the theoretical requirement of raw materials (**Plates, Sheets, Sections and Pipes**).

10. TRANSFER / RETURN OF LEFT OVER MATERIALS:

Party should maintain proper records for receipt & use of all free issue materials. The left over materials & scrap as per the material accounting statement shall be returned to HPVP stores along with finished job. Material Transfer Vouchers (MTV) from one order to another or from one vendor to another and Material Return Vouchers should be submitted immediately after transfer / return. The material reconciliation statement shall be submitted by the contractor after verification and certification by BHEL along with the final bill **within 30 days from the date of completion of work**. Otherwise, recovery for the balance materials shall be made from any of their pending bills without further intimation.

11. MATERIAL RECONCILIATION:

Orders issued to the vendors have to be completed in all respects including Material Accounting within a maximum of **180 days** from the **date of issue of the first material** from BHEL - HPVP stores.

Cutting & Process Allowance: Maximum of 10% on the requirement of materials (**Sheets, Plates, and Rods**) is admitted towards **cutting & process allowance and invisible wastage**.

Rejection: Maximum 5% of rejection is allowed, rejected component shall also be supplied to BHEL, failing which material cost for the rejected components shall be recovered by BHEL from vendor bills.

Milling & Machining Scrap: Quantity of scrap generated from Milling & Machining shall be as per applicable drawings. However quantity of scrap shall be approved by BHEL at the time of material reconciliation. Milling & Machining scrap like chips, burrs etc. shall not be returned to BHEL.

If rejection and scrap is beyond above limits/applicable drawing requirements, it should be fully justified with cutting diagrams etc. which are to be approved in advance by BHEL. **Otherwise, the cost of raw materials beyond approved limits will be recovered from the contractor bills as per BHEL recovery rates including applicable taxes & duties.**

Material reconciliation including return of balance materials, off-cuts is to be completed within 20 days from the date of completion of the order. The material reconciliation statement shall be submitted by the contractor after verification and certification by BHEL-HPVP along with the final bill **within 30 days from the date of completion of work**. Otherwise, recovery for the balance materials shall be made from any of their pending bills without further intimation,

Repeated occurrence of inordinate delays in returning and settling the material accounting will entail BHEL the right to terminate the contract forthwith or impose a temporary suspension on further loading at the discretion of BHEL.

12. SCRAP & OFF-CUT NORMS:

Sl. No.	Description	Scrap Size (in mm)	Off-Cut (in MM)
1.	MDN, SS, Aluminium Sheets & Plates	Below 50 × 50	50 × 50 & above
2.	Rolled sections Rod, angles etc. (other than -tubes, pipes)	Below 50	50 & above
3.	Tubes & Pipes	Below 40	40 & above

Note: Scraps mentioned above need not be necessarily returned to BHEL, however same should be part of material reconciliation.

13. INSPECTION:

Party shall contact our Quality Control Dept. for stages of inspection before commencement of job and should strictly follow the stages of inspection as per QAP.

14. WORKMANSHIP GUARANTEE:

The vendors should give workmanship guarantee for fabricated items for a period of 18 months from the date of last delivery of the order. Any defects due to incomplete work, faulty workmanship found in the fabricated items after delivery during the defects liability period shall be rectified / replaced by the vendor free of cost. Otherwise, the expenditure incurred towards the same will be recovered from the pending bills of vendors.

15. WORK PROGRESS:

The fabricator shall furnish a weekly report on the progress of work along with the status of availability of free issue materials and requirement of further materials, if any.

Outsourcing dept. personnel will visit vendor's works from time to time to assess and review the work progress. Free access shall be provided to BHEL or its inspection agency at all reasonable times of the day / night.

In case the progress is not satisfactory or supplies are delayed abnormally beyond the contractual delivery date, BHEL-HPVP, Visakhapatnam reserves the right to cancel the order in part or full or get the balance job in as is where is condition completed elsewhere by another agency at the risk and cost of Fabricator. The value of the work carried out by the party will be assessed by BHEL and the same shall be final. No compensation will be given to the fabricator in case of cancellation of order or diversion of balance job even if the jobs have been processed partly.

16. DELIVERY:

Finished items should be handed over to BHEL-HPVP on party's delivery challans along with Job completion certificate / Final Inspection Report from inspection agency / HPVP-QC department.

17. PENALTY:

If delivery exceeds the stipulated delivery schedule, penalty 1/2 % of the total value of order per week or part there of subject to a maximum of 10% on the total value of the order will be levied. However, time taken for the following will not be considered as delay on the part of the Sub-Contractor.

- 1) Intermediate operations, if any, carried out by BHEL.
- 2) Waiting time for BHEL / Third party Inspection beyond a normal time of 3 days.

18. PAYMENT TERMS:

Payment shall be made against RA Bills within 45 days from the date of submission of Bill.

90% payment will be made after handing over of the finished equipments along with all inspection documents to HPVP shops / Logistics dept. / ADM site / Lova Garden site, duly inspected & cleared by Inspection authority. Balance 10% payment shall be made along with the Final Bill against completion of total order in all respects including documentation.

Vendors shall have to submit the bills in the formats specified by HPVP-Outsourcing and the bills submitted in the specified format along with necessary supporting documents are only admitted for processing. The following documents shall be submitted along with the Final Bill: -

1. No Claim Certificate from the contractor
2. No Dues Certificate from BHEL
3. Work Completion Certificate from BHEL
4. Material Reconciliation Statement submitted by the Contractor and certified by concerned authority of BHEL (if applicable)
5. Workmanship Guarantee certificate from the contractor

19. SECRECY:

All the documents of BHEL inclusive of Drawings, GMS and Standards made available to the fabricator should be kept in strict confidence and under no circumstance be made available to others or allow others to make use of them. Such documents shall be returned to BHEL on demand after completion of the job. This secrecy clause is binding on the employees of the fabricators also. Violation of the same may lead to suspension of business with the vendor and necessary legal action.

20. SUB-LETTING:

In general, sub-letting of jobs will not be permitted. But in special circumstances, this may be allowed. In such case, the party should obtain written approval from BHEL-HPVP, Visakhapatnam before sub-letting.

21. FACTORY RULES AND REGULATIONS:

Party shall abide by all the rules and statutory regulations in force from time to time as per factories act. It shall be party's responsibility to ensure the safety of their workmen and fulfilling the ESI, PF and other relevant statutory regulations.

22. SAFETY:

- a) Contractor shall adhere to safe construction practices, guard against hazardous & unsafe working conditions and shall comply with the safety rules of BHEL and local authorities. He shall maintain First Aid facilities for all his employees and labour. Contractor's responsibility includes supply of welder kit, all safety items such as safety belts, white and colour glasses, goggles, safety helmets, safety shoes etc.
- b) *Contractor and his employees shall follow all fire & safety, security regulations of BHEL.*

23. HOUSE KEEPING:

During execution of work, the contractor at all times keep the working place and storage area clean and free from accumulation of waste materials, rubbish etc.,

24. ACCIDENT / DAMAGE / CONDUCT ETC.:

Contractor will be held responsible for any disorderly conduct / misconduct, indiscipline, theft, smoking etc., on the part of his men. He will ensure summarily eviction of such men from his premises failing which BHEL would remove them from the factory on his responsibility. Any damage to and or loss of equipment, machinery, building etc., to BHEL or BHEL employees, visitors or other contractors resulting from his own or any of his men's negligence shall be liable to be made good by him. Contractor shall be solely responsible for any accident in which you or your men or your equipment may be involved during the execution of contract on account of any reason what so ever.

25. TERMINATION OF CONTRACT:

In the event of any failure on the part of the contractor, BHEL reserves the right to terminate the contract by giving a notice of 2 weeks for any of the following lapses and contractual violations: -

- a) Failure to make labour payments in time as per the rules
- b) Failure to progress the job according to the agreed schedule
- c) Failure to mobilize adequate man power, tools & tackles and consumables in time
- d) Failure to adhere to Quality Standards of BHEL
- e) Refused to co-operate with other agencies working in the same area
- f) Failure to resolve labour disputes like strikes etc., within 7 days of occurrence
- g) Failure to comply with statutory regulations applicable at BHEL

BHEL shall also be free to intervene and take necessary remedial measures. All costs incurred with interest and overheads shall be recovered from contractor by such foreclosing or off-loading any part of the contract work.

26. DISPUTES:

Head of BHEL- HPVP Unit will be the final authority for any disputes arising out of this contract. The disputes / arbitration / settlement of contractual or legal issues shall be under the Jurisdiction of Visakhapatnam Court.

27. For this procurement, Public Procurement (Preference to Make in India), Order 2017 dated 15.06.2017 & 28.05.2018 and subsequent Orders issued by the respective Nodal Ministry shall be applicable even if issued after issue of this NIT but before finalization of Contract / PO / WO against this NIT.

In the event of any Nodal Ministry prescribing higher or lower percentage of purchase preference and / or local content in respect of this procurement, same shall be applicable.

28. The Bidder declares that they will not enter into any illegal or undisclosed agreement or understanding, whether formal or informal with other Bidder(s). This applies in particular to prices, specifications, certifications, subsidiary contracts, submission or non-submission of bids or any other actions to restrict competitiveness or to introduce cartelization in the bidding process.

In case, the Bidder is found having indulged in above activities, suitable action shall be taken by BHEL as per extant policies/ guidelines.

Signature of the Bidder with Stamp

Acceptance to Tender Terms & Conditions

I / We hereby confirm that the Tender documents, Drawings, Quality documents etc. have been studied in detail and we have fully understood the scope of work.

I / We accept to all the Terms and Conditions of the Tender Enquiry and the prices quoted are in accordance with the same.

I / We give our acceptance to participate in reverse auction for this tender.

Tender documents duly signed on all the pages by the Owner / authorized representative of the bidder are attached herewith.

Signature of the Bidder with Stamp

BUSINESS RULES FOR REVERSE AUCTION (RA)

This has reference to tender no. **OS/22-23/R&D/5603/07/007, dated 16.06.2022**. BHEL shall finalize the Rates for **Manufacturing of Welding Fixture Components (SS) for Heat Exchangers of Su-30 Mk-1 Aircraft against S.O. No. 5603 at Vendor's works with free issue materials** through Reverse Auction mode. BHEL has made arrangement with an authorized Service provider (details will be shared before reverse auction) for conducting RA. Bidders should go through the instructions given below and submit acceptance of the same.

The technical & commercial terms are as per (a) BHEL Tender Enquiry No. **OS/22-23/R&D/5603/07/007, dated 16.06.2022**, (b) Bidders' technical & commercial bid (in case of two-part bid) and (c) subsequent correspondences between BHEL and the bidders, if any.

1. Procedure of Reverse Auctioning:

- i) Price bids of all techno-commercially qualified bidders shall be opened.
- ii) **Reverse Auction:** The 'bid decrement' will be decided by BHEL.
- iii) The lowest bidder in sealed envelope price bid shall be shown as current L1 automatically by the system and no acceptance of that price is required. System shall have the provision to indicate this bid as current L1.
- iv) Bidders by offering a minimum bid decrement or the multiples thereof can displace a standing lowest bid and become "L1" and this continues as an iterative process. However, no bidder shall be allowed to lower its bid below the current L1 by more than 5 decrements at one go.
- v) After the completion of the reverse auction, the Closing Price shall be available for further processing.
- vi) **Wherever the evaluation is done on total cost basis, after Reverse Auction, prices of individual line items shall be reduced on pro-rata basis.**

2. Schedule for reverse auction: The Reverse Auction schedule will be intimated to all the eligible techno-commercially qualified bidders at a later stage.**3. Auction extension time:** If a bidder places a bid in the last 5 minutes of closing of the Reverse Auction and if that bid gets accepted, then the auction's duration shall get extended automatically for another 5 minutes, for the entire auction (i.e. for all the items in the auction), from the time that bid comes in. Please note that the auto-extension will take place only if a bid comes in those last 5 minutes and if that bid gets accepted as the lowest bid. If the bid does not get accepted as the lowest bid, the auto-extension will not take place even if that bid might have come in the last 5 minutes. In case, there is no bid in the last 5 minutes of closing of Reverse Auction, the auction shall get closed automatically without any extension. However, bidders are advised not to wait till the last minute or last few seconds to enter their bid during the auto-extension period to avoid complications related with internet connectivity, network problems, system crash down, power failure, etc.

The above process will continue till completion of Reverse Auction.

Complaints/ Grievances, if any, regarding denial of service or any related issue should be given in writing thru e-mail/ fax to M/s. {Service provider} with a copy to BHEL within 15 minutes prior to initial closing time of Reverse Auction.

4. Bid price: The Bidder has to quote the {.....} Price **except GST** but inclusive of Packing & Forwarding charges, all the routine & type tests as per tender scope, taxes, duties, freight and insurance as specified in tender document including loading (if indicated by BHEL due to deviations in technical/ commercial terms) for the Items specified. Details are as shown in Excel Sheet for calculation of total cost to BHEL (To be specified by Unit as per NIT conditions).**5. Bidding currency and unit of measurement:** Bidding will be conducted in **Indian Rupees per Unit** of the material as per the specifications mentioned in the tender.

In case of foreign currency bids, exchange rate (TT selling rate of State Bank of India) as on scheduled date of tender opening (Part-I bid) shall be considered for conversion in Indian Rupees. If the relevant day happens to be a Bank holiday, then the forex rate as on the previous bank (SBI) working day shall be taken.

6. **Validity of bids:** Price shall be valid for **3 months from the date of reverse auction**. These shall not be subjected to any change whatsoever.
7. **Lowest bid of a bidder:** In case the bidder submits more than one bid, the lowest bid at the end of Reverse Auction will be considered as the bidder's final offer to execute the work.
8. Unique user IDs shall be used by bidders during bidding process. All bids made from the Login ID given to the bidders will be deemed to have been made by the bidders/ bidders' company.
9. **Post auction procedure:** BHEL will proceed with the Lowest Bid in the Reverse Auction for further processing.
10. Any commercial/ technical loading shall be separately intimated to respective bidders prior to RA. The excel sheet provided in this regard shall cover all these aspects. Commercial/ technical loading if any, shall be added by the respective bidder in its price during Reverse Auction. Modalities of loading & de-loading shall be separately intimated to the bidders. The responsibility for correctness of total cost to BHEL shall lie with the bidders.
11. Reverse auction shall be conducted by BHEL (through M/s {*Service Provider*}), on pre-specified date, while the bidders shall be quoting from their own offices/ place of their choice. Internet connectivity shall have to be ensured by bidders themselves.

During the RA process if a bidder is not able to bid and requests for extension of time by FAX/ email/ phone then time extension of additional 15 minutes will be given by the service provider provided such requests come before 5 minutes of auction closing time. However, only one such request per bidder can be entertained.

In order to ward-off contingent situation of connectivity failure bidders are requested to make all the necessary arrangements/ alternatives whatever required so that they are able to circumvent such situation and still be able to participate in the reverse auction successfully. Failure of power or loss of connectivity at the premises of bidders during the Reverse auction cannot be the cause for not participating in the reverse auction. On account of this, the time for the auction cannot be extended and neither BHEL nor M/s. {*Service provider*} is responsible for such eventualities.

12. **Proxy bids:** Proxy bidding feature is a pro-bidder feature to safe guard the bidder's interest of any internet failure or to avoid last minute rush. The proxy feature allows bidders to place an automated bid in the system directly in an auction and bid without having to enter a new amount each time a competing bidder submits a new offer. The bid amount that a bidder enters is the minimum that the bidder is willing to offer. Here the software bids on behalf of the bidder. This obviates the need for the bidder participating in the bidding process until the proxy bid amount is decrementally reached by other bidders. When proxy bid amount is reached, the bidder (who has submitted the proxy bid) has an option to start participating in the bidding process.

The proxy amount is the minimum amount that the bidder is willing to offer. During the course of bidding, the bidder cannot delete or change the amount of a proxy bid.

Bids are submitted in decrements (decreasing bid amounts). The application automates proxy bidding by processing proxy bids automatically, according to the decrement that the auction originator originally established when creating the auction, submitting offers to the next bid decrement each time a competing bidder bids, regardless of the fact whether the competing bids are submitted as proxy or standard bids. However, it may please be noted that if a manual bid and proxy bid are submitted at the same instant manual bid will be recognized as the L1 at that instant.

In case of more than one proxy bid, the system shall bid till it crosses the threshold value of 'each lowest proxy bid' and thereafter allow the competition to decide the final L1 price.

Proxy bids are fed into the system directly by the respective bidders. As such this information is privy only to the respective bidder(s).

13. Bidders are advised to get fully trained and clear all their doubts such as refreshing of Screen, quantity being auctioned, tender value being auctioned etc. from M/s. {*Service provider*}.

14. M/s. {*Service provider*}, shall arrange to demonstrate/ train the bidder or bidder's nominated person(s), without any cost to bidders. M/s. {*Service provider*}, shall also explain the bidders, all the business rules related to the Reverse Auction. Bidders are required to submit their acceptance to the terms/ conditions/ modalities before participating in the Reverse Auction in the process compliance form as enclosed. Without this, the bidder will not be eligible to participate in the event.
15. Successful bidder shall be required to submit the final prices (L1) in prescribed format (Annexure – VI) for price breakup, quoted during the Reverse Auction, duly signed and stamped as token of acceptance without any new condition (other than those already agreed to before start of auction), after the completion of auction to M/s. {*Service provider*} besides BHEL within two working days of Auction without fail.
16. Any variation between the final bid value and that in the confirmatory signed price breakup document will be considered as tampering the tender process and will invite action by BHEL as per extant guidelines for suspension of business dealings (as available on www.bhel.com).
17. Bidders' bid will be taken as an offer to execute the work/ supplies the item as per enquiry no. **OS/22-23/R&D/5603/07/007, dated 16.06.2022**. Bids once made by the bidder, cannot be cancelled/ withdrawn and bidder shall be bound to execute the work as mentioned above at bidder's final bid price. Should bidder back out and not execute the contract as per the rates quoted, BHEL shall take action as per extant guidelines for suspension of business dealings (as available on www.bhel.com).
18. Bidders shall be able to view the following on their screen along with the necessary fields during Reverse Auction:
 - a. Leading (Running Lowest) Bid in the Auction (only total price of package)
 - b. Bid Placed by the bidder
 - c. Start Price
 - d. Decrement value
 - e. Rank of their own bid during bidding as well as at the close of auction.
19. BHEL's decision on award of contract shall be final and binding on all the Bidders.
20. BHEL reserves the right to extend, reschedule or cancel the Reverse Auction process at any time, before ordering, without assigning any reason, with intimation to bidders.
21. BHEL shall not have any liability to bidders for any interruption or delay in access to the site irrespective of the cause. In such cases, the decision of BHEL shall be binding on the bidders.
22. Other terms and conditions shall be as per bidder's techno-commercial offers and other correspondences, if any, till date.
23. If there is any clash between this business document and the FAQ available, if any, in the website of M/s. {*Service provider*}, the terms & conditions given in this business document will supersede the information contained in the FAQs. Any changes made by BHEL/ service provider (due to unforeseen contingencies) after the first posting shall be deemed to have been accepted if the bidder continues to access the portal after that time.
24. Bidder shall not divulge either his Bids or any other exclusive details of BHEL to any other party. If the Bidder or any of his representatives are found to be involved in Price manipulation/ cartel formation of any kind, directly or indirectly by communicating with other bidders, action *as per extant BHEL guidelines for suspension of business dealings (as available on www.bhel.com)*, shall be initiated by BHEL.

Signature of the Bidder with Stamp

PROCEDURE FOR GST PAYMENT

1. In Response to Tenders for Indigenous supplier will be entertained only if the vendor has a valid GSTIN which should be clearly mentioned in the offer. If any specific exemption is available, a declaration with due supporting documents need to be furnished for considering the offer.
2. Supplier shall mention their GSTIN in all their invoices and invoices shall be in the format as specified/prescribed under GST laws. Invoices shall necessarily contain Invoice number (in case of multiple numbering system is being followed for billing like SAP invoice no, commercial invoice no etc., then the Invoice No which is linked/uploaded in GSTN network shall be clearly indicated), item description as per PO, Quantity, Rate, Value, applicable taxes with nomenclature (like IGST, SGST, CGST & UTGST) separately, HSN/ SAC Code, etc.
3. All invoices shall bear the HSN Code for each item separately (Harmonized System of Nomenclature)/ SAC code (Services Accounting Code).
4. A declaration to the effect that all invoice particulars are/were uploaded in the GSTN network/ portal & all tax liability as per GST rules and regulations have been and will be discharged, shall be mentioned in the invoice. If not mentioned in the invoice, a separate declaration shall be submitted as per the requirement of BHEL.
5. All documents like Test Certificate, LR copy, Guarantee/Warrantee certificate, work completion certificate, any other document mentioned in PO, shall be sent along with the vehicle/consignment where ever applicable. For all consignments received within the calendar month, input credit will be availed within that month in line with monthly returns filing cycle. In case of any discrepancy in the document or non-submission of documents mentioned in the PO, then BHEL will not be able to accept or account the material, in such case availing of tax credit will be deferred to next month or so.
6. In case of discrepancy in the data uploaded by supplier in the GSTN portal or in case of any shortages or rejection in the supply, then BHEL will not be able to avail the tax credit and will notify the supplier of the same. Supplier has to rectify the data discrepancy in the GSTN portal or issue credit note (details to be uploaded in GSTN portal) for the shortages or rejections in the suppliers, within the calendar month notified by BHEL.
7. For any such delay in availing of tax credit for reasons attributable to supplier (as mentioned above), interest (calculated @ SBI Base Rate + 6%) along with penalty if any will be deducted for the delayed period i.e. from the month of receipt till the month tax credit is availed, from the running bills.
8. Under GST regime, BHEL has to discharge GST liability on LD recovered from suppliers/contractors. Hence applicable GST shall also be recoverable from suppliers/contractors on LD amount. For this Debit note will be issued by BHEL indicating the respective supply invoice number.
9. This is to inform that GST portion of invoice, shall be released only upon Vendor declaring such invoice in his GSTR-1 and receipt of goods and Tax invoice by BHEL and Confirmation of payment of GST thereon by vendor on GSTN portal. Alternatively, BG of appropriate value may be obtained from vendor which shall be valid At least one month after the confirmation of date of payment of GST by vendor on GSTN portal and receipt of Tax invoice and receipt of goods, whichever is later. Above is subject to receipt of goods/service and tax invoice thereof along with vendor declaring invoice in his return and paying GST within timeline prescribed for availing ITC by BHEL.
10. That in case vendor delays Declaring such invoice in his return and GST credit availed by BHEL is denied or reversed subsequently as per GST law, GST amount paid by BHEL towards such ITC reversal as per GST law shall be recoverable from vendor/contractor along with interest levied/ leviable on BHEL.

Note : The above will be followed strictly for processing vendor payments to ensure GST Compliance.

Signature of the Bidder with Stamp

DRG NO: RD-SU30-F-A-00001

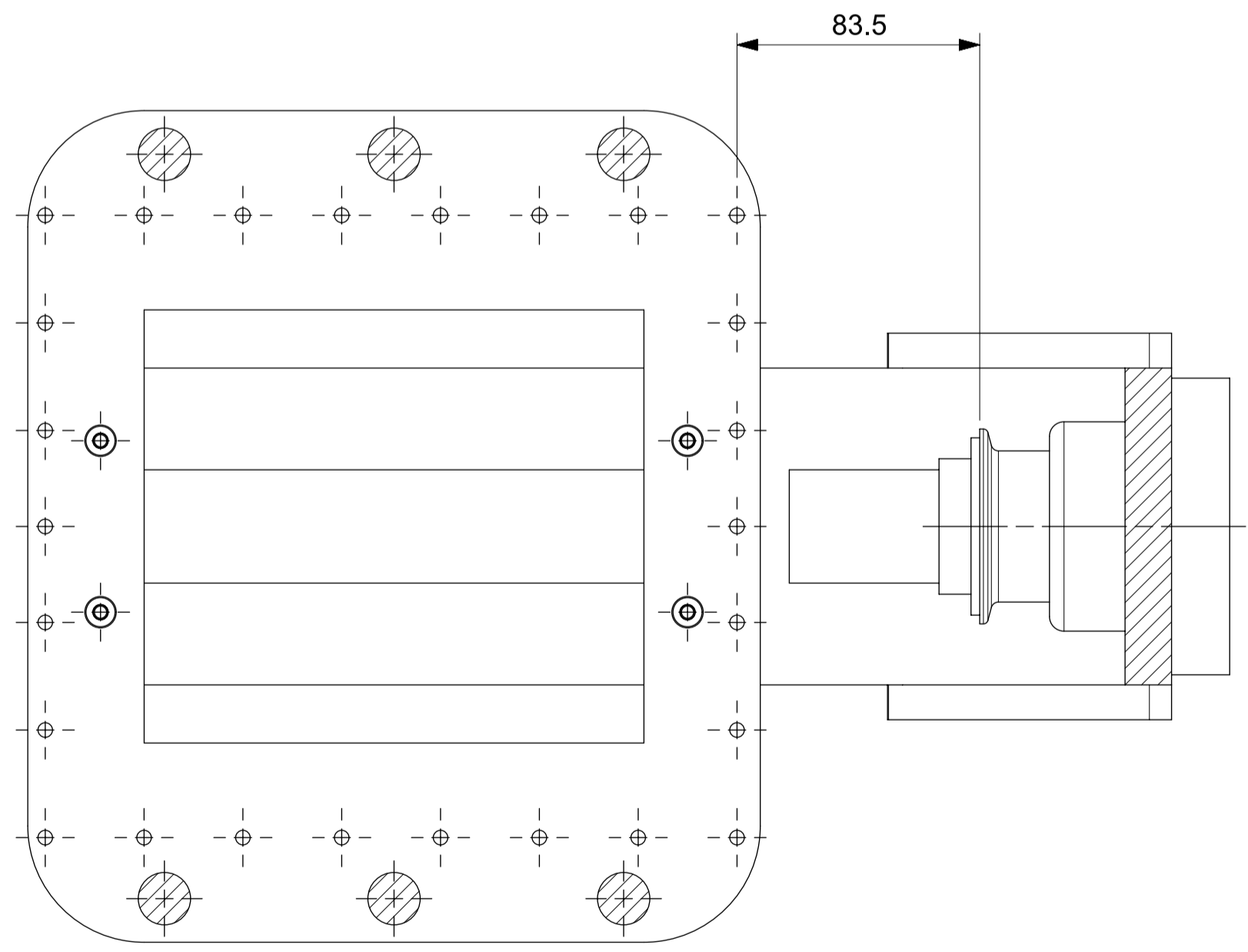
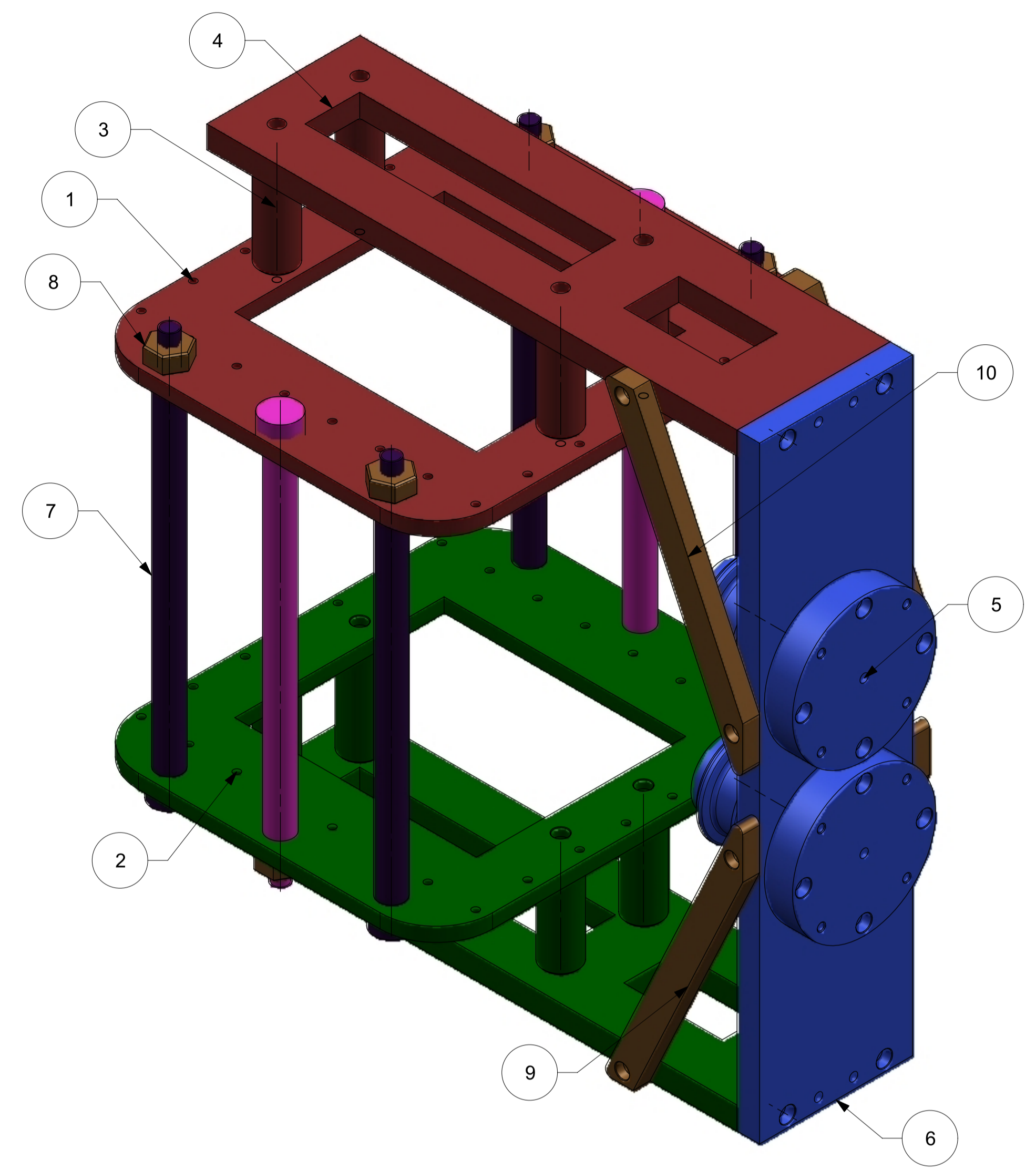
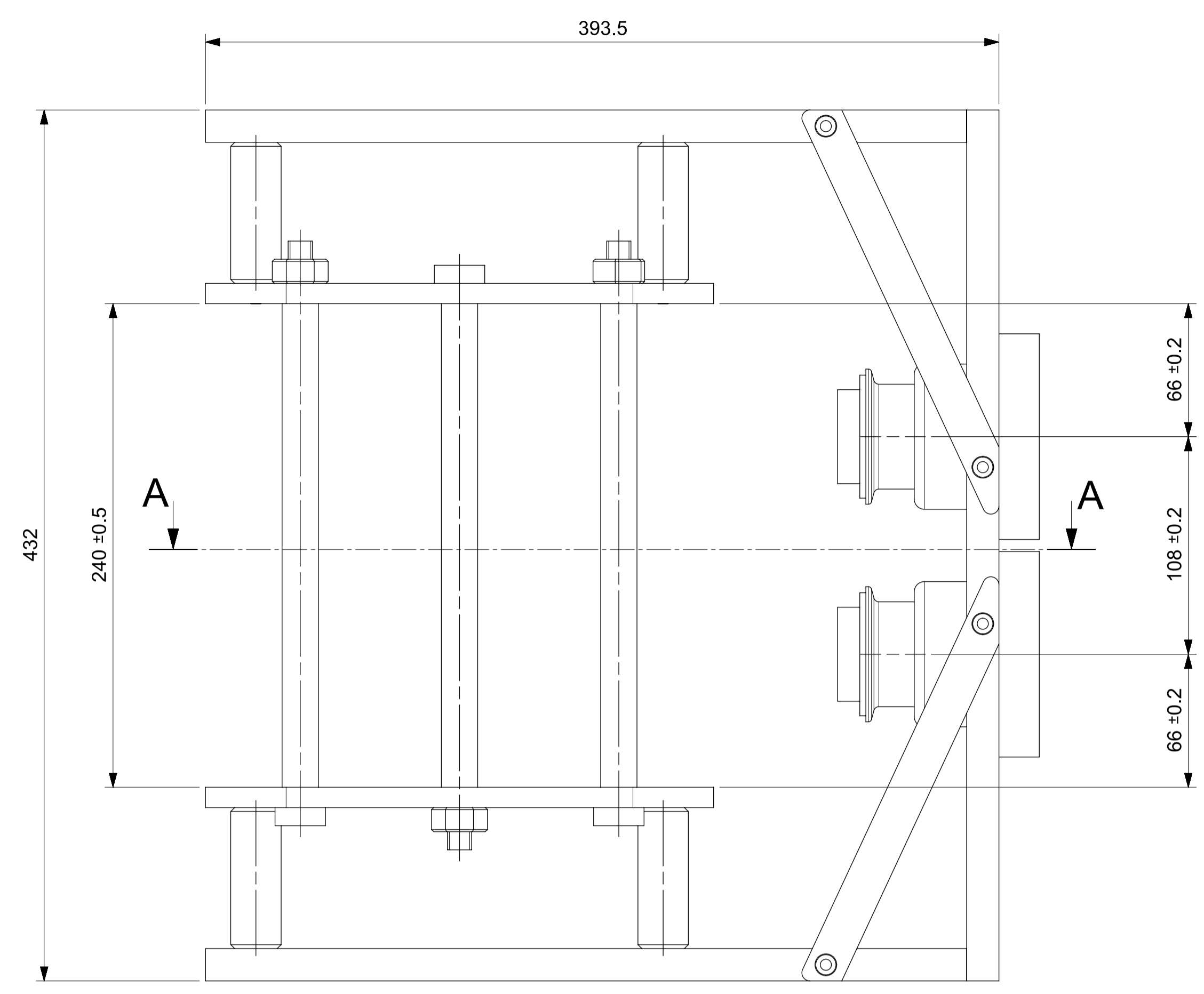

SECTION A-A

NOTES:

1. DEBURR ALL SHARP EDGES.
2. ASSEMBLE ALL THE PARTS AFTER MACHINING.
3. ASSEMBLY TOLERANCES TO BE MAINTAINED WITH IN LIMITS (DEVIATIONS NOT ACCEPTABLE).
4. PART NO 5 AND 6 SHOULD HAVE A CLOSE RUNNING FIT.
5. ALLEN HEADED SCREWS, NUTS AND LOCATING PINS SHOULD BE SUPPLIED BY VENDOR.

PART NO	DESCRIPTION	REF DRG NUMBER	RAW MATERIAL	UNIT NET WT IN KGS	QTY
10	STIFFENER-1	RD-SU30-F-P-00 010	SS 316 /321	0.381	2
9	STIFFENER	RD-SU30-F-P-00 009	SS 316 /321	0.381	2
8	CLAMPING NUTS 1	BOC	SS 316 /321	0.039	6
7	CLAMPING STUDS-1	RD-SU30-F-P-00 008	SS 316 /321	0.575	6
6	CLAMPING PLATE-1	RD-SU30-F-P-00 007	SS 316 /321	4.791	1
5	FERRULE COVER -1	RD-SU30-F-P-00 006	SS 316 /321	2.447	2
4	BOLTING PLATE TOP	RD-SU30-F-P-00 005	SS 316 /321	3.868	2
3	SUPPORT-1	RD-SU30-F-P-00 004	SS 316 /321	0.264	8
2	BOTTOM COUNTER FLANGE	RD-SU30-F-P-00 003	SS 316 /321	3.338	1
1	TOP COUNTER FLANGE	RD-SU30-F-P-00 002	SS 316 /321	3.359	1

BHARAT HEAVY ELECTRICALS LTD.
 HEAVY PLATES & VESSELS PLANT
 VISAKHAPATNAM - 530012, INDIA.

RESEARCH AND DEVELOPMENT

CUSTOMER: BHEL INTERNAL

TITLE: SU30 WELDING FIXTURE

SCALE: 1:2

REF DRAWING NO: NA
 YEAR OF ORDER: DRAWING NUMBER: REV. 00

NA RD-SU30-F-A-00001 00

SHEET 1 OF 1 SIZE: A1

UNLESS OTHERWISE SPECIFIED TOLERANCES ON DIMENSIONS ARE			
LINEAR	RANGE	5 - 50	51 - 250
	TOL (MM)	±0.5	±1.5
		±1.5	±2.5
ANGULAR		± 1.5°	
SURFACE FINISH	SYMBOL	▽▽	▽
	TOL (um)	0.025 to 1.6	1.6 to 8
		8 to 25	

REV	DATE	ALTERED	REV	DATE	ALTERED	REV	DATE	ALTERED	REV	DATE	ALTERED	REV	DATE	ALTERED
		CHD/APPD			CHD/APPD			CHD/APPD			CHD/APPD			CHD/APPD
ZONE			ZONE			ZONE			ZONE			ZONE		

THE INFORMATION IN THIS DOCUMENT IS THE PROPERTY OF BHARAT HEAVY ELECTRICALS LIMITED. IT MUST NOT BE USED DIRECTLY OR INDIRECTLY IN ANY DETRIMENTAL TO INTEREST OF THE COMPANY

RD-SU30-F-P-00002
DRG NO:

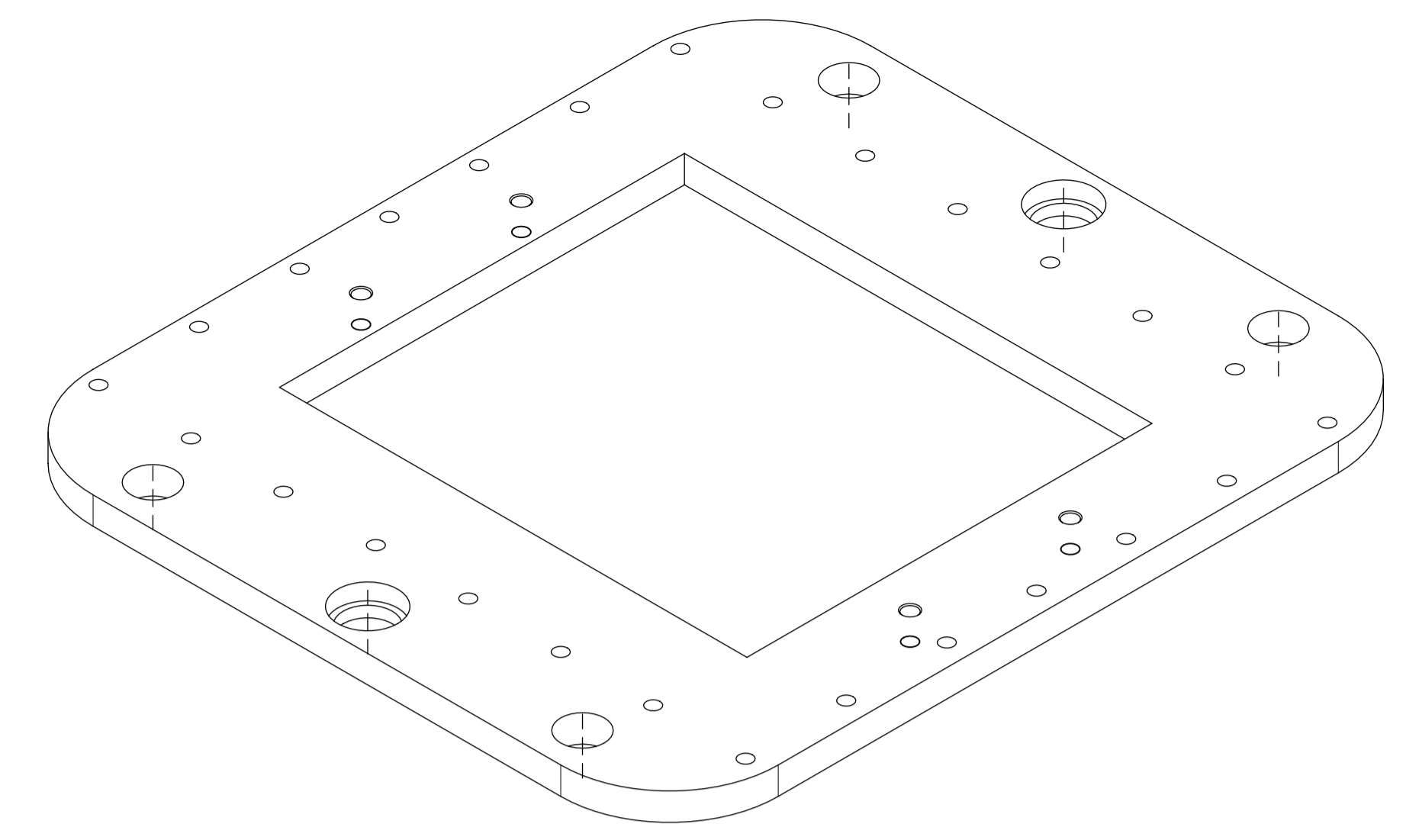
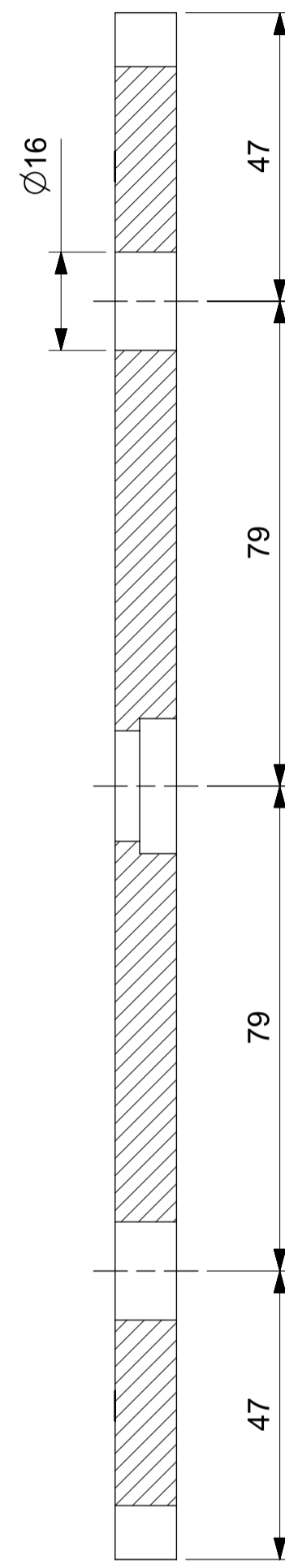
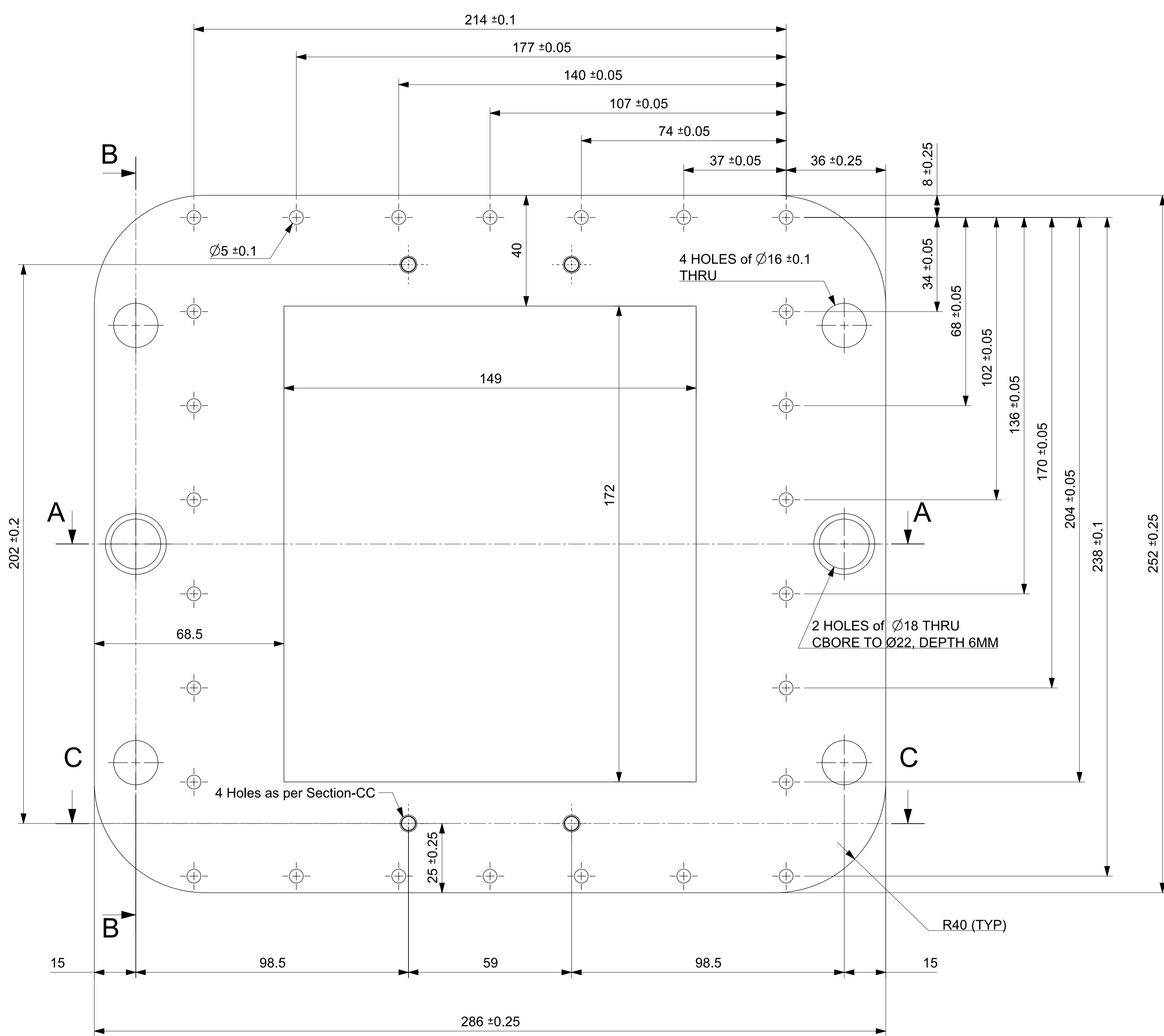

- NOTES:
1. DEBURR ALL SHARP EDGES.
2. TOLERANCES TO BE MAINTAINED WITH IN LIMITS (DEVIATIONS NOT ACCEPTABLE).

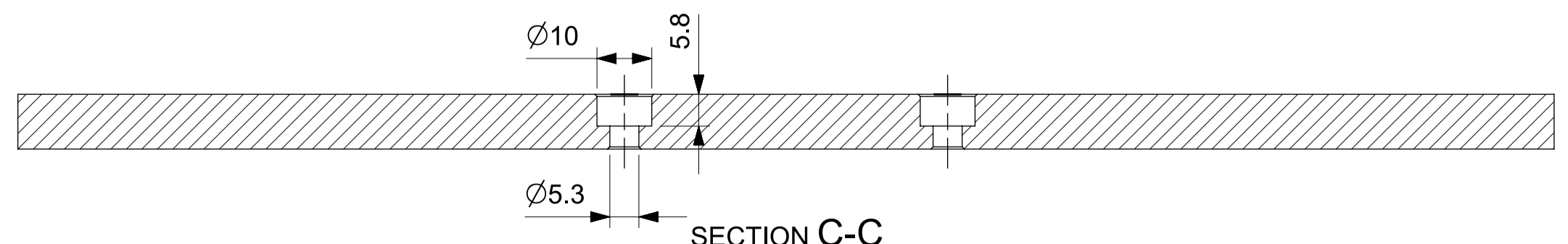

UNLESS OTHERWISE SPECIFIED TOLERANCES ON DIMENSIONS ARE

LINEAR	RANGE	5 - 50	51 - 250	> 250
	TOL (MM)	±0.5	±1.5	±2.5
ANGULAR		± 1.5°		
SURFACE FINISH	SYMBOL	∇∇	∇	
	TOL (µm)	0.025 to 1.6	1.6 to 8	8 to 25

REV	DATE	ALTERED	REV	DATE	ALTERED	REV	DATE	ALTERED	REV	DATE	ALTERED	REV	DATE	ALTERED
		CHD/APPD			CHD/APPD			CHD/APPD			CHD/APPD			CHD/APPD
ZONE			ZONE			ZONE			ZONE			ZONE		

		BHARAT HEAVY ELECTRICALS LTD.	
HEAVY PLATES & VESSELS PLANT		VISAKHAPATNAM - 530012, INDIA.	
DRAWN	ANAND	RESEARCH AND DEVELOPMENT	
CHECKED	S MANDAL	CUSTOMER	BHEL INTERNAL
APPROVED	SRINIVAS	TITLE	TOP COUNTER FLANGE
SCALE 1:1		REF DRAWING NO	RD-SU30-F-A-00001
ALL PROJECTIONS ARE IN FIRST ANGLE UNLESS OTHERWISE SPECIFIED		YEAR OF ORDER	DRAWING NUMBER
		RD-SU30-F-P-00002	REV. 00
SHEET 1 OF 1		SIZE: A1	

THE INFORMATION IN THIS DOCUMENT IS THE PROPERTY OF BHARAT HEAVY ELECTRICALS LIMITED. IT MUST NOT BE USED DIRECTLY OR INDIRECTLY IN ANY DETRIMENTAL TO INTEREST OF THE COMPANY

RD-SU30-F-P-00003
DRG NO:

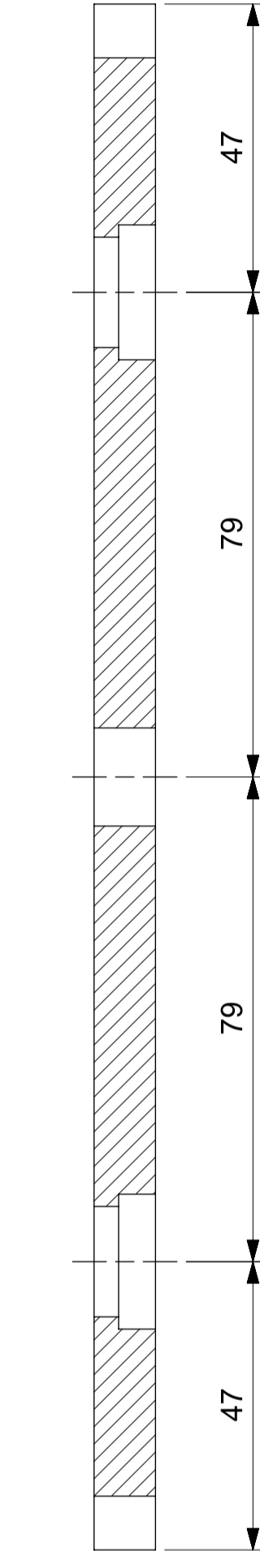
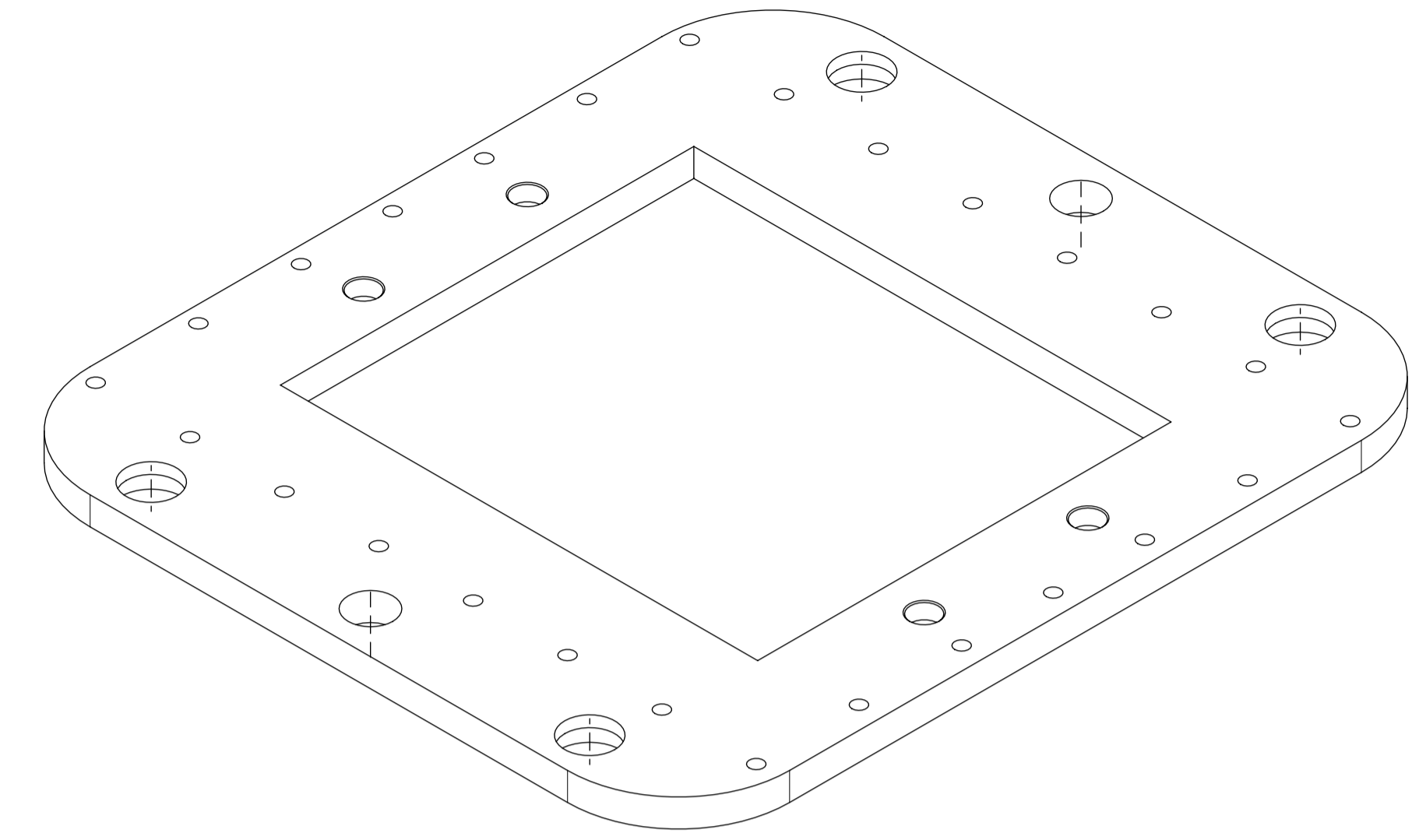
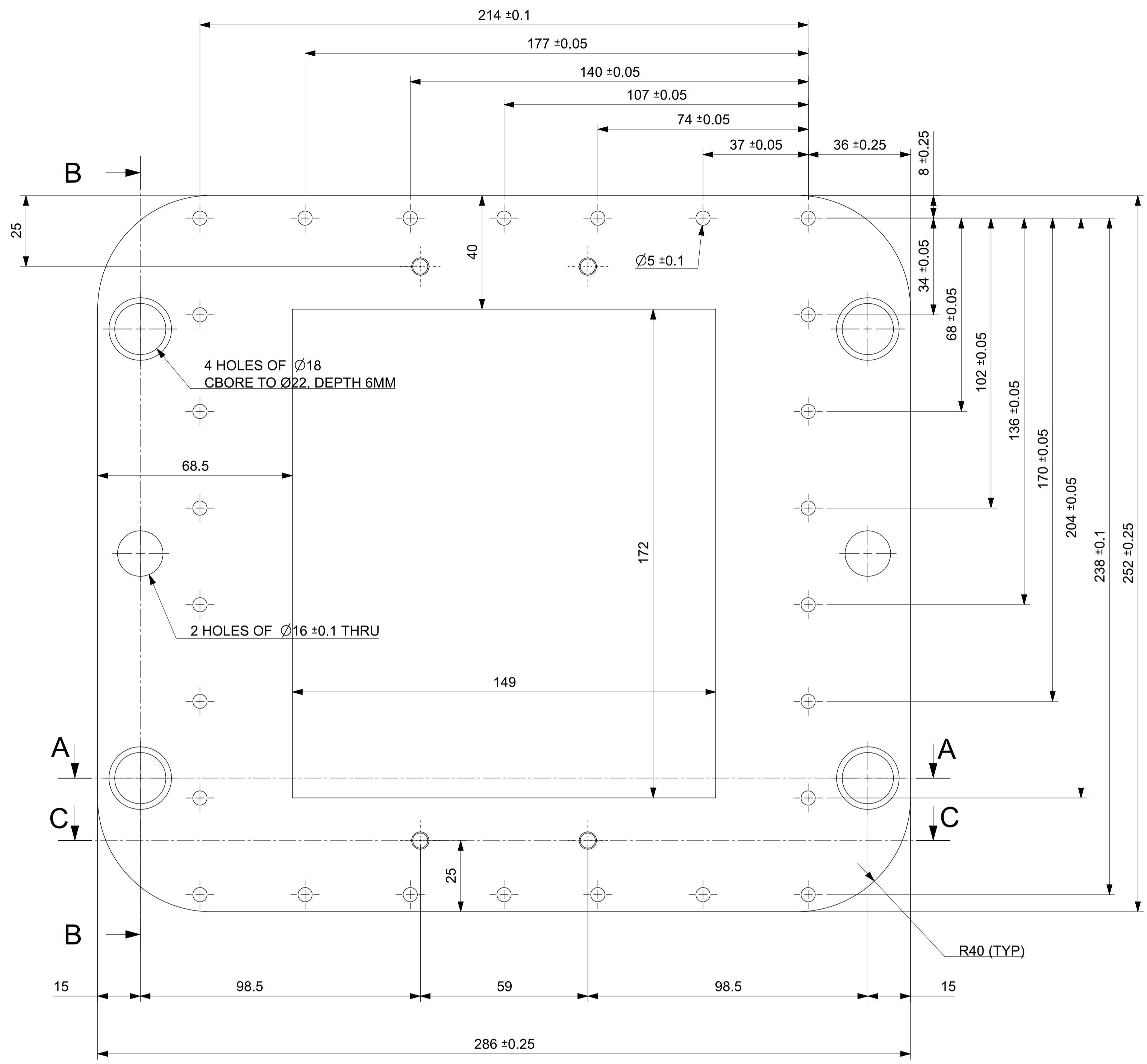

- NOTES:
 1. DEBURR ALL SHARP EDGES.
 2. TOLERANCES TO BE MAINTAINED WITH IN LIMITS (DEVIATIONS NOT ACCEPTABLE).

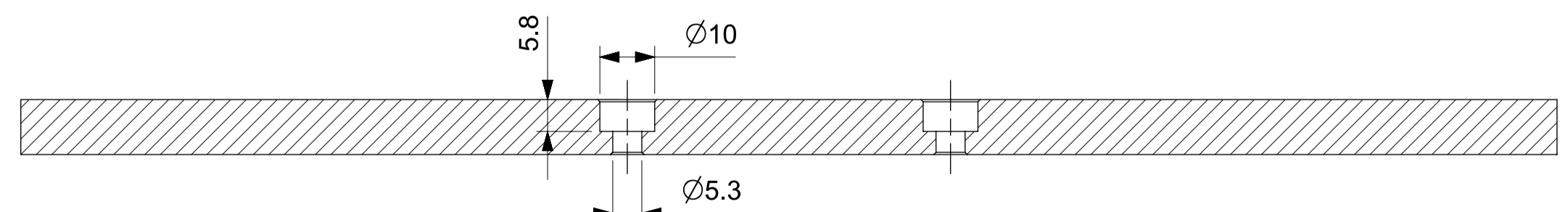

UNLESS OTHERWISE SPECIFIED TOLERANCES ON DIMENSIONS ARE			
LINEAR	RANGE	5 - 50	51 - 250
	TOL (MM)	±0.5	±1.5
			> 250
			±2.5
ANGULAR		± 1.5°	
SURFACE FINISH	SYMBOL	∇∇	∇
	TOL (µm)	0.025 to 1.6	1.6 to 8
		8 to 25	

REV	DATE	ALTERED	REV	DATE	ALTERED	REV	DATE	ALTERED	REV	DATE	ALTERED	REV	DATE	ALTERED
		CHD/APPD			CHD/APPD			CHD/APPD			CHD/APPD			CHD/APPD
ZONE			ZONE			ZONE			ZONE			ZONE		

		BHARAT HEAVY ELECTRICALS LTD.			
		HEAVY PLATES & VESSELS PLANT			
		VISAKHAPATNAM - 530012, INDIA.			
DRAWN	ANAND	RESEARCH AND DEVELOPMENT			
CHECKED	S MANDAL	CUSTOMER		BHEL INTERNAL	
APPROVED	SRINIVAS	TITLE		BOTTOM COUNTER FLANGE	
SCALE 1:1		REF DRAWING NO	RD-SU30-F-A-00001		
ALL PROJECTIONS ARE IN FIRST ANGLE UNLESS OTHERWISE SPECIFIED		YEAR OF ORDER	DRAWING NUMBER		REV.
		--	RD-SU30-F-P-00003		00
		SHEET 1 OF 1		SIZE: A1	

THE INFORMATION IN THIS DOCUMENT IS THE PROPERTY OF BHARAT HEAVY ELECTRICALS LIMITED. IT MUST NOT BE USED DIRECTLY OR INDIRECTLY IN ANY DETRIMENTAL TO INTEREST OF THE COMPANY

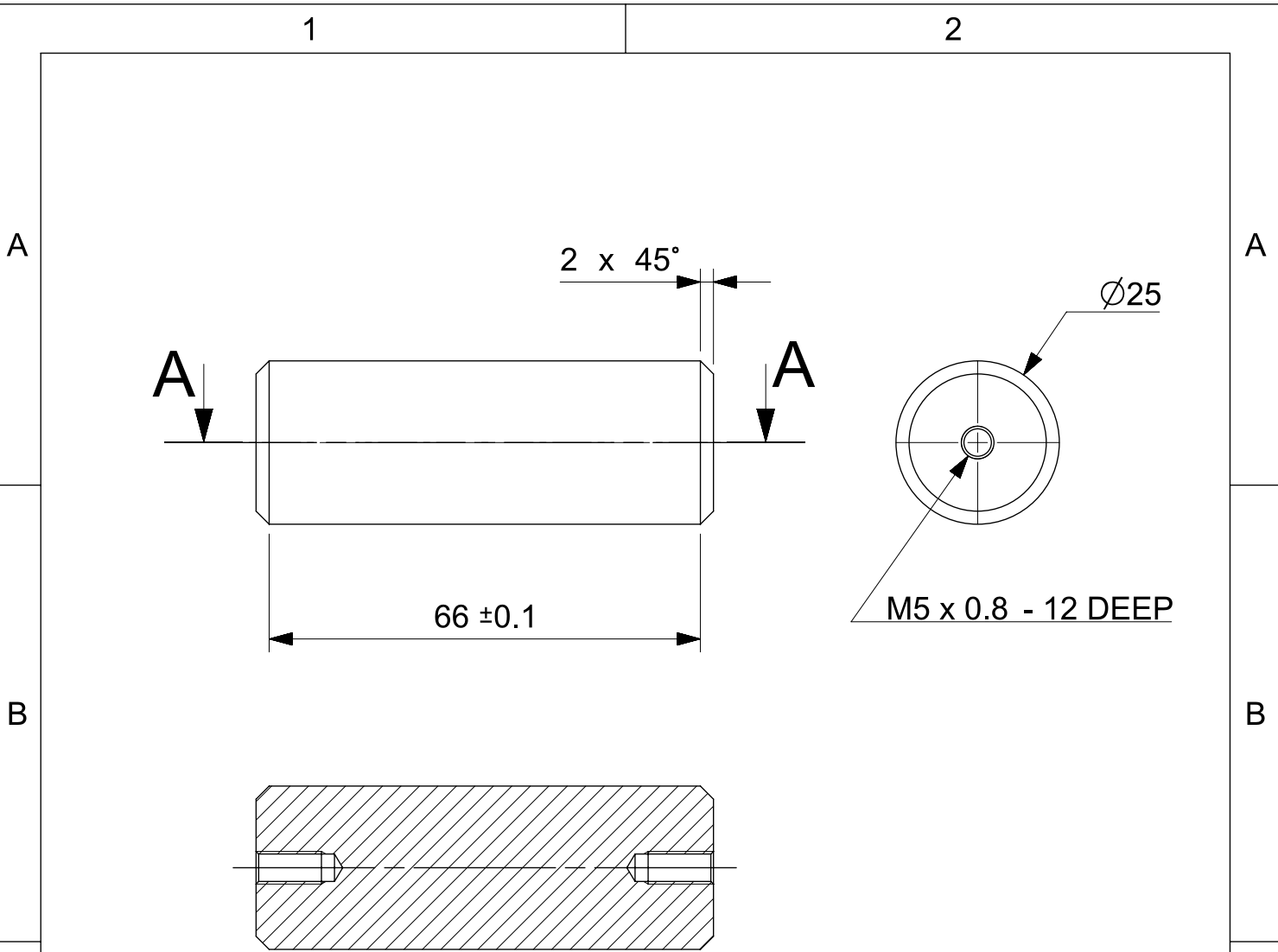

SECTION A-A

NOTES:

- 1. DEBURR ALL SHARP EDGES.
- 2. TOLERANCES TO BE MAINTAINED WITH IN LIMITS (DEVIATIONS NOT ACCEPTABLE).

THE INFORMATION IN THIS DOCUMENT IS THE PROPERTY OF BHARAT HEAVY ELECTRICALS LIMITED. IT MUST NOT BE USED DIRECTLY OR INDIRECTLY IN ANY DETRIMENTAL TO INTEREST OF THE COMPANY

REV	DATE	ALTERED		REV	DATE	ALTERED			
		CHD/APPD				CHD/APPD			
ZONE				ZONE					
PART NO				BHARAT HEAVY ELECTRICALS LTD HEAVY PLATES & VESSELS PLANT VISAKHAPATNAM - 530012, INDIA.					
MATERIAL									
QTY				DRN	ANAND	RESEARCH AND DEVELOPMENT			
UNLESS OTHERWISE SPECIFIED TOLERANCES ON DIMENSIONS ARE				CHK	S MANDAL	CUSTOMER		BHEL INTERNAL	
				APD	SRINIVAS	TITLE		SUPPORT-1	
LINEAR	RANGE	5 - 50	51 - 250	> 250	ALL PROJECTIONS ARE IN FIRST ANGLE UNLESS OTHERWISE SPECIFIED		REF DRAWING NO	RD-SU30-F-A-00001	
	TOL (MM)	±0.5	±1.5	±2.5			YEAR OF ORDER	DRAWING NUMBER	REV.
ANGULAR	± 1.5°						--	RD-SU30-F-P-00004	00
SURFACE FINISH	SYMBOL						SHEET 1 OF 1		
	TOL (um)	0.025 to 1.6	1.6 to 8	8 to 25			SIZE: A4		

1 DRG NO: RD-SU30-F-P-00005

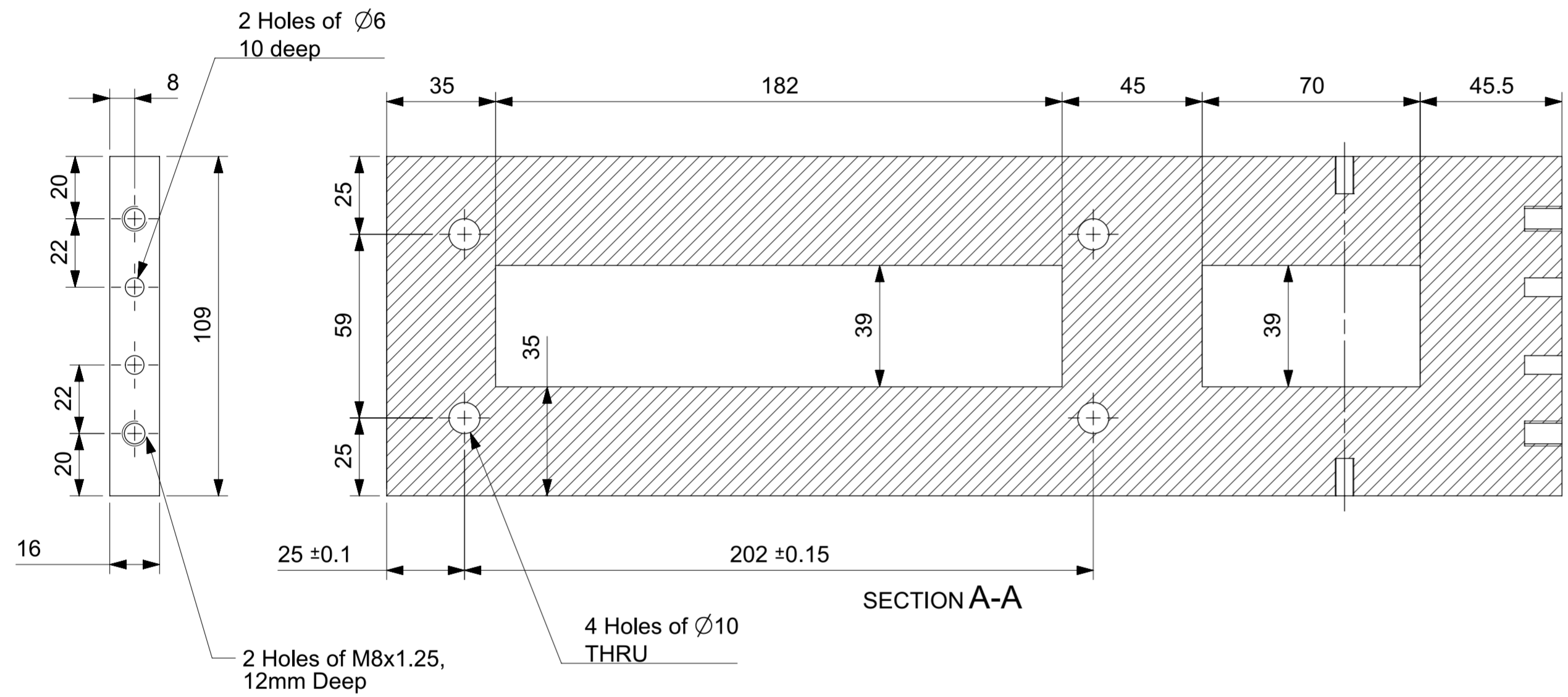
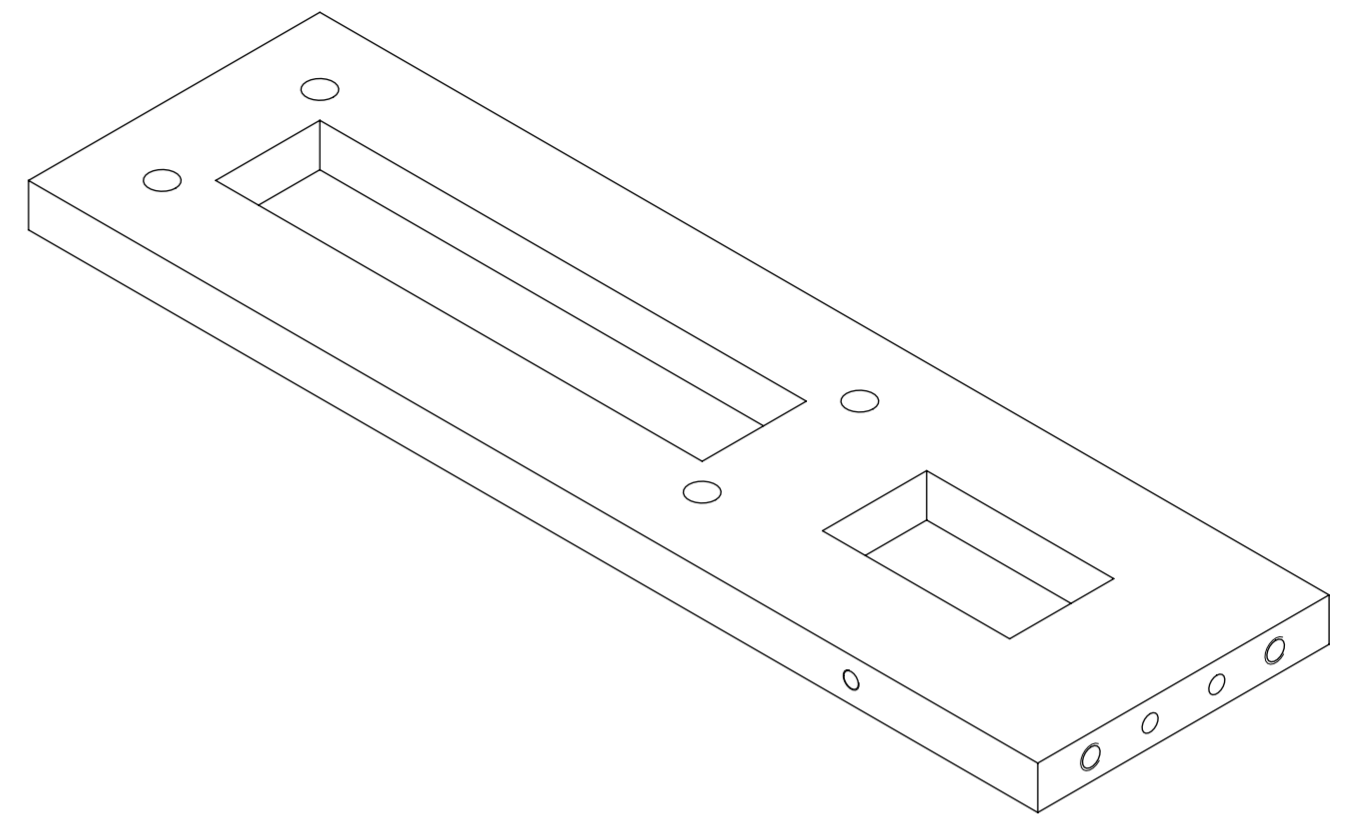
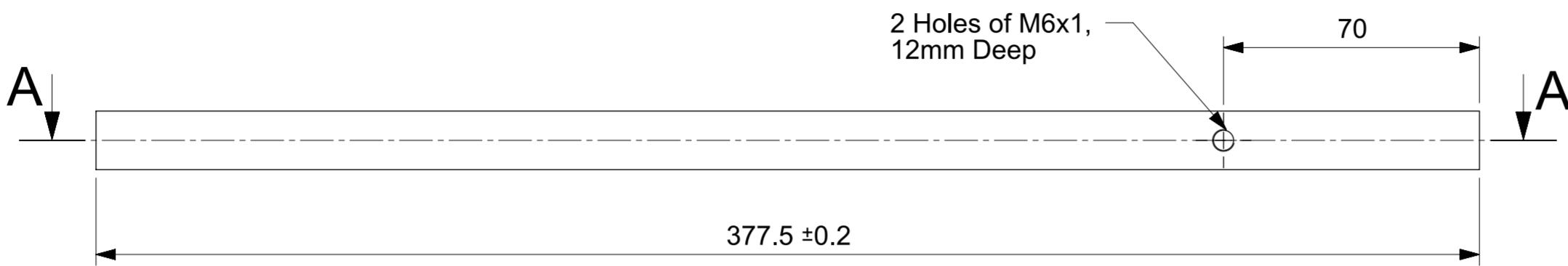

- NOTES:**
1. DEBURR ALL SHARP EDGES.
 2. TOLERANCES TO BE MAINTAINED WITH IN LIMITS (DEVIATIONS NOT ACCEPTABLE).

UNLESS OTHERWISE SPECIFIED TOLERANCES ON DIMENSIONS ARE				
LINEAR	RANGE	5 - 50	51 - 250	> 250
	TOL (MM)	±0.5	±1.5	±2.5
ANGULAR		± 1.5°		
SURFACE FINISH	SYMBOL	VVV	VV	V
	TOL (µm)	0.025 to 1.6	1.6 to 8	8 to 25

REV	DATE	ALTERED	REV	DATE	ALTERED	REV	DATE	ALTERED
		CHD/APPD			CHD/APPD			CHD/APPD
ZONE			ZONE			ZONE		

		BHARAT HEAVY ELECTRICALS LTD. HEAVY PLATES & VESSELS PLANT VISAKHAPATNAM - 530012, INDIA.			
		DRAWN ANAND CHECKED S MANDAL APPROVED SRINIVAS SCALE 1:1	RESEARCH AND DEVELOPMENT CUSTOMER BHEL INTERNAL		TITLE BOLTING PLATE
ALL PROJECTIONS ARE IN FIRST ANGLE UNLESS OTHERWISE SPECIFIED		REF DRAWING NO RD-SU30-F-A-00001	YEAR OF ORDER	DRAWING NUMBER RD-SU30-F-P-00005	REV. 00
SHEET 1 OF 1			SIZE: A2		

THE INFORMATION IN THIS DOCUMENT IS THE PROPERTY OF BHARAT HEAVY ELECTRICALS LIMITED. IT MUST NOT BE USED DIRECTLY OR INDIRECTLY IN ANY DETRIMENTAL TO INTEREST OF THE COMPANY

A
B
C
D
E

A
B
C
D
E

90000-BHARAT
RD-SU30-F-P-00006
DRG NO:

0.8
M

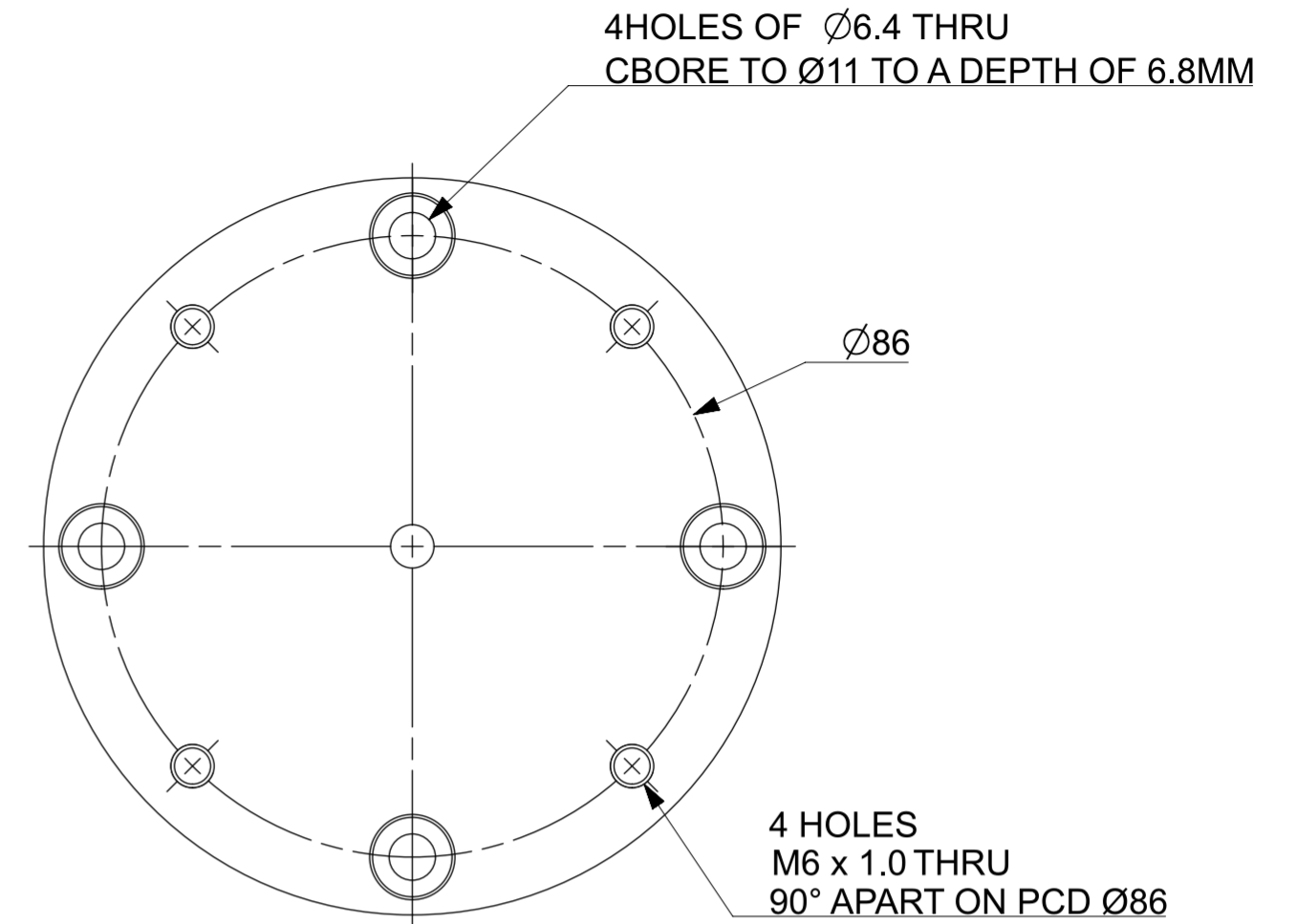
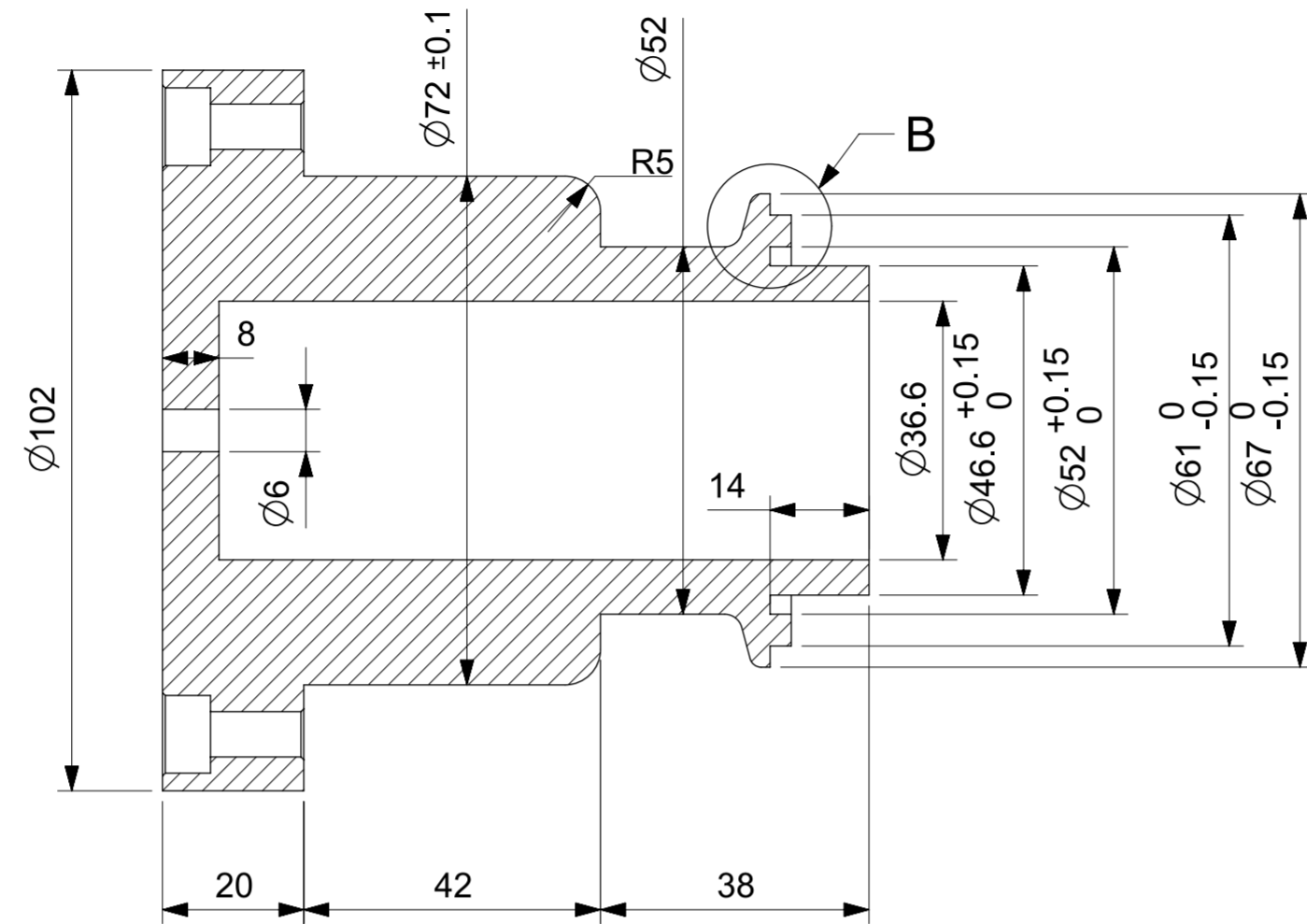
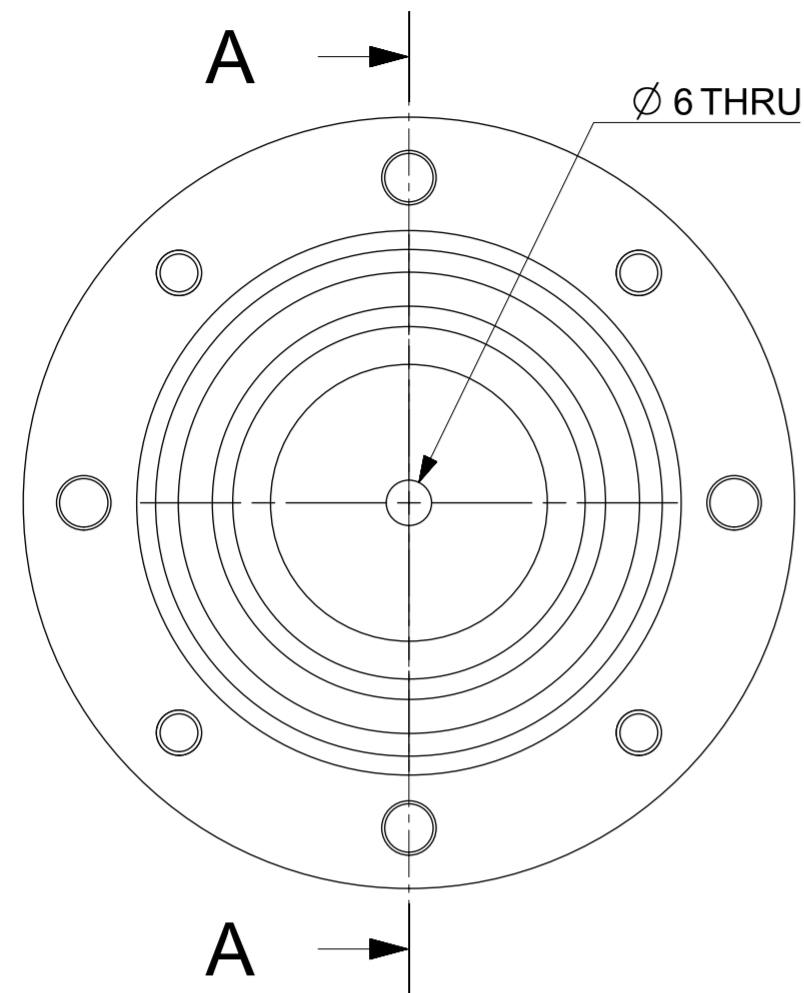

SECTION A-A

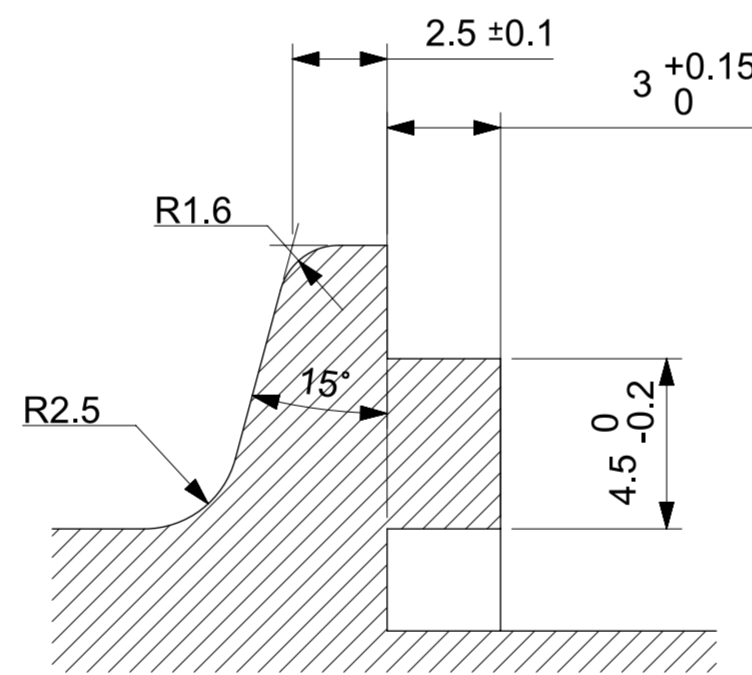
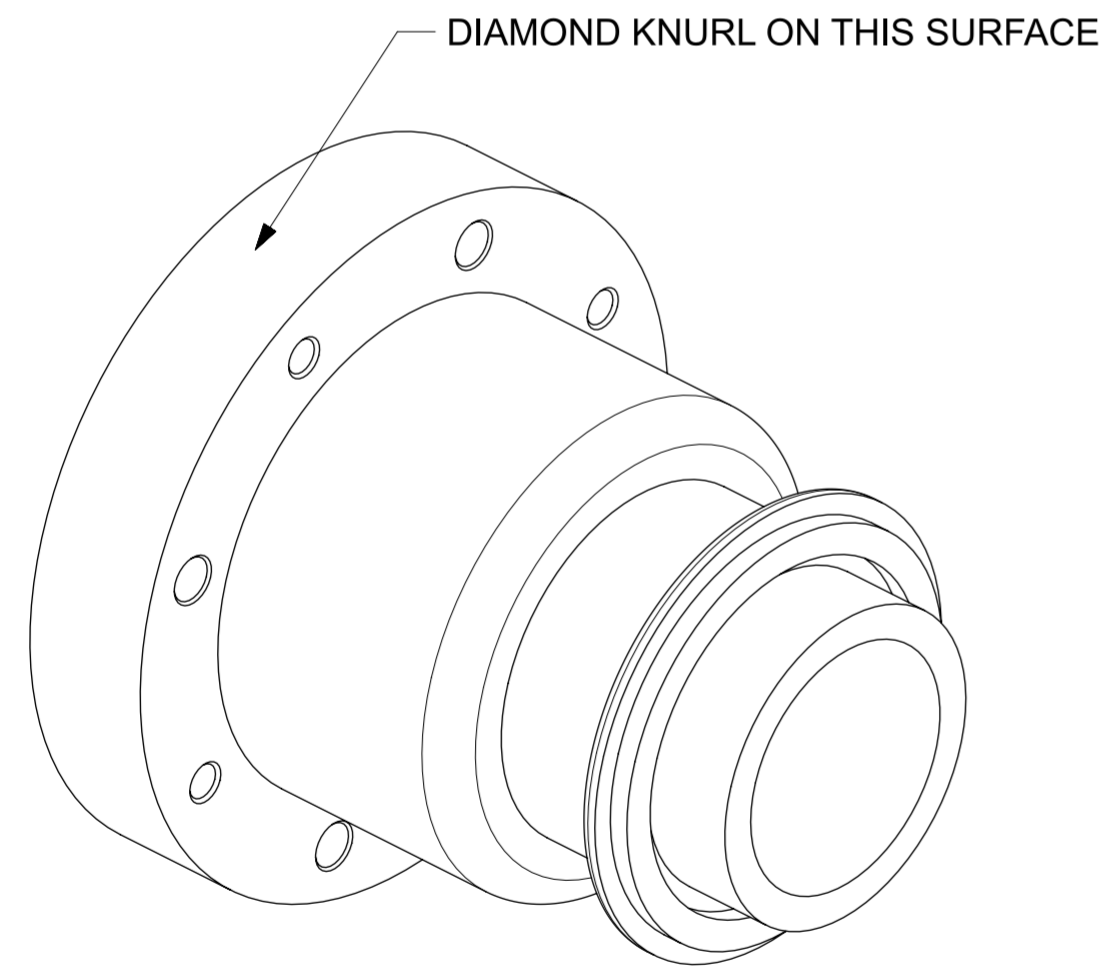

DETAIL B
SCALE 5:1

- NOTES:
1. DEBURR ALL SHARP EDGES.
2. TOLERANCES TO BE MAINTAINED WITH IN LIMITS (DEVIATIONS NOT ACCEPTABLE).

THE INFORMATION IN THIS DOCUMENT IS THE PROPERTY OF BHARAT HEAVY ELECTRICALS LIMITED. IT MUST NOT BE USED DIRECTLY OR INDIRECTLY IN ANY DETRIMENTAL TO INTEREST OF THE COMPANY

UNLESS OTHERWISE SPECIFIED TOLERANCES ON DIMENSIONS ARE				
LINEAR	RANGE	5 - 50	51 - 250	> 250
	TOL (MM)	±0.5	±1.5	±2.5
ANGULAR		± 1.5°		
SURFACE FINISH	SYMBOL	∇∇∇	∇∇	∇
	TOL (µm)	0.025 to 1.6	1.6 to 8	8 to 25

REV	DATE	ALTERED	REV	DATE	ALTERED	REV	DATE	ALTERED
		CHD/APPD			CHD/APPD			CHD/APPD
ZONE			ZONE			ZONE		

		BHARAT HEAVY ELECTRICALS LTD. HEAVY PLATES & VESSELS PLANT VISAKHAPATNAM - 530012, INDIA.			
		DRAWN ANAND CHECKED S MANDAL APPROVED SRINIVAS SCALE 1:1	RESEARCH AND DEVELOPMENT CUSTOMER BHEL INTERNAL		TITLE FERRULE COVER-1
ALL PROJECTIONS ARE IN FIRST ANGLE UNLESS OTHERWISE SPECIFIED		REF DRAWING NO RD-SU30-F-A-00001	YEAR OF ORDER	DRAWING NUMBER RD-SU30-F-P-00006	REV. 00
		SHEET 1 OF 1	SIZE: A2		

RD-SU30-F-P-00007
DRG NO:

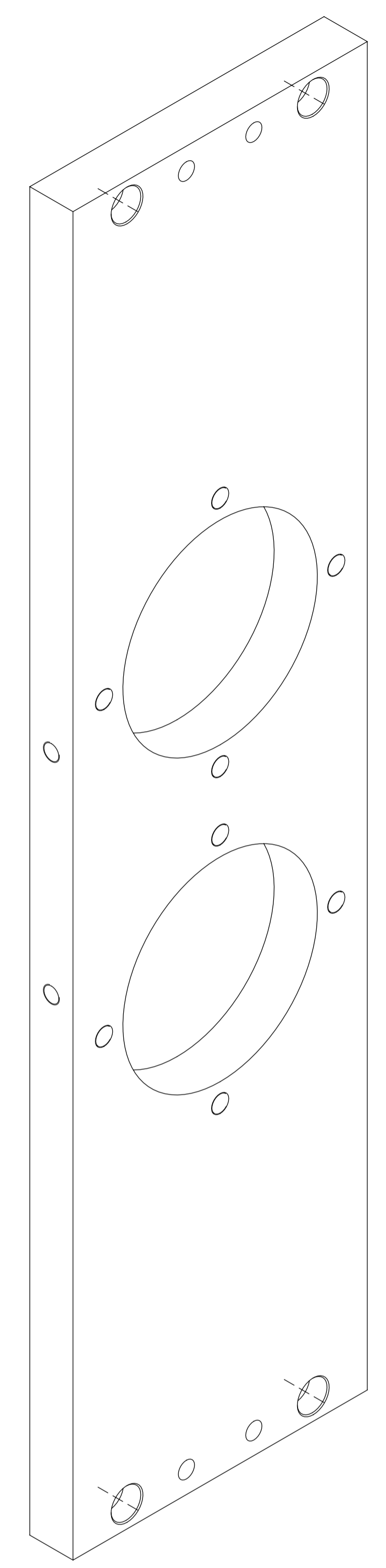
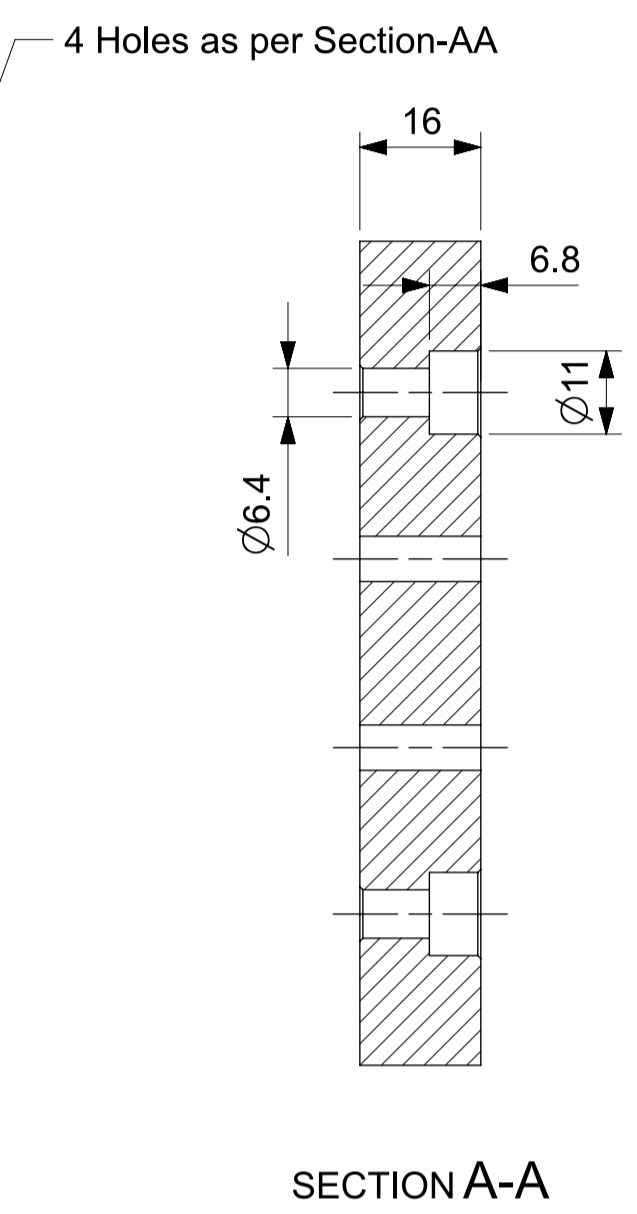
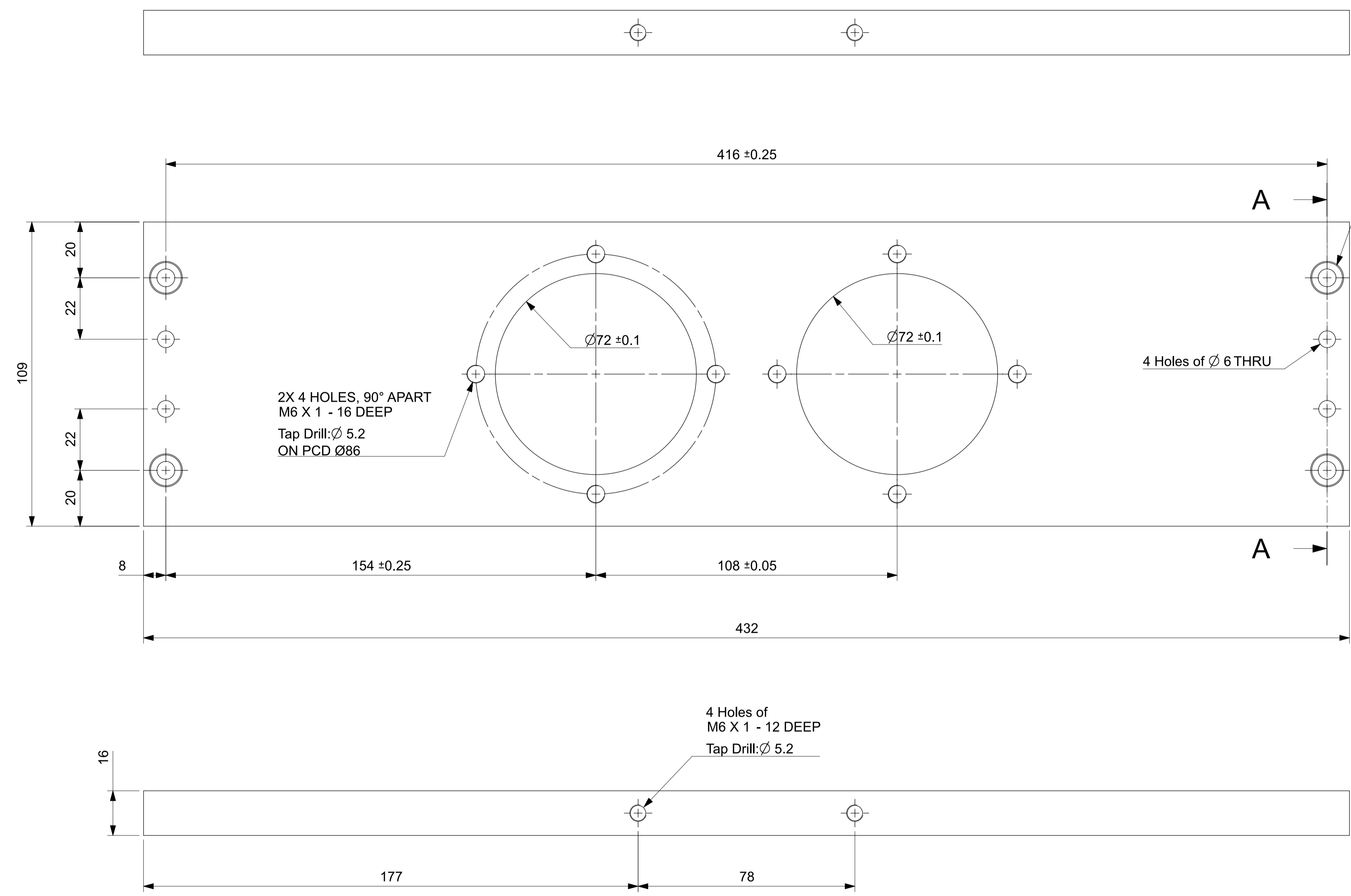

NOTES:
 1. DEBURR ALL SHARP EDGES.
 2. TOLERANCES TO BE MAINTAINED WITH IN LIMITS (DEVIATIONS NOT ACCEPTABLE).

THE INFORMATION IN THIS DOCUMENT IS THE PROPERTY OF BHARAT HEAVY ELECTRICALS LIMITED. IT MUST NOT BE USED DIRECTLY OR INDIRECTLY IN ANY DETRIMENTAL TO INTEREST OF THE COMPANY

UNLESS OTHERWISE SPECIFIED TOLERANCES ON DIMENSIONS ARE			
LINEAR	RANGE	5 - 50	51 - 250
	TOL (MM)	±0.5	±1.5
			> 250
			±2.5
ANGULAR		± 1.5°	
SURFACE FINISH	SYMBOL	∇∇	∇
	TOL (um)	0.025 to 1.6	1.6 to 8
		8 to 25	

REV	DATE	ALTERED	REV	DATE	ALTERED	REV	DATE	ALTERED	REV	DATE	ALTERED	REV	DATE	ALTERED
		CHD/APPD			CHD/APPD			CHD/APPD			CHD/APPD			CHD/APPD
ZONE			ZONE			ZONE			ZONE			ZONE		

		BHARAT HEAVY ELECTRICALS LTD.	
HEAVY PLATES & VESSELS PLANT		VISAKHAPATNAM - 530012, INDIA.	
DRAWN	ANAND	RESEARCH AND DEVELOPMENT	
CHECKED	S MANDAL	CUSTOMER	BHEL INTERNAL
APPROVED	SRINIVAS	TITLE	
SCALE 1:1		CLAMPING PLATE-1	
ALL PROJECTIONS ARE IN FIRST ANGLE UNLESS OTHERWISE SPECIFIED		REF DRAWING NO	RD-SU30-F-A-00001
		YEAR OF ORDER	DRAWING NUMBER
		REV.	00
		SHEET 1 OF 1	SIZE: A1

RD-SU30-F-P-00008

DRG NO:

0.8
M

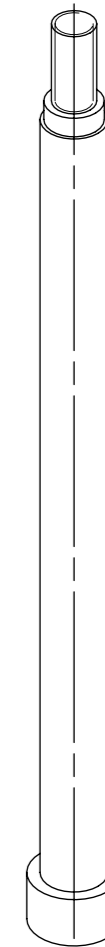
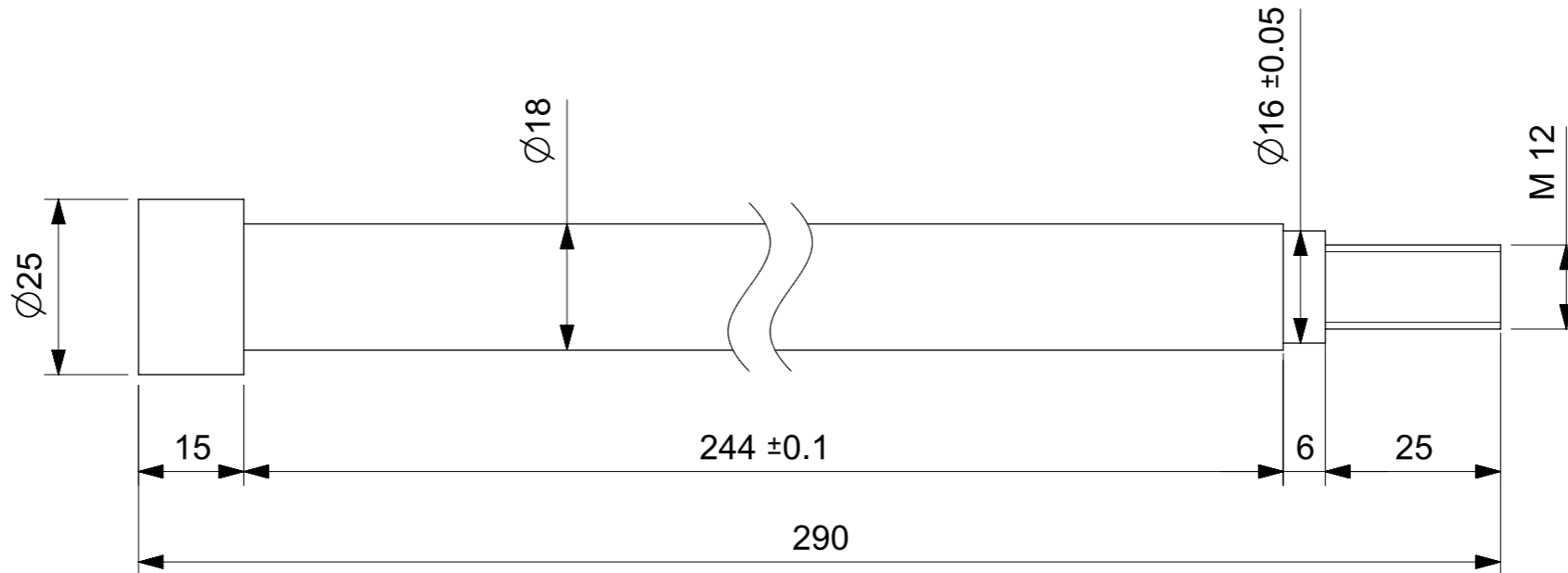
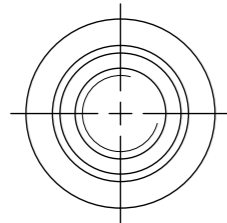

NOTES:

1. DEBURR ALL SHARP EDGES.
2. TOLERANCES TO BE MAINTAINED WITH IN LIMITS (DEVIATIONS NOT ACCEPTABLE).

THE INFORMATION IN THIS DOCUMENT IS THE PROPERTY OF BHARAT HEAVY ELECTRICALS LIMITED. IT MUST NOT BE USED DIRECTLY OR INDIRECTLY IN ANY DETRIMENTAL TO INTEREST OF THE COMPANY

UNLESS OTHERWISE SPECIFIED TOLERANCES ON DIMENSIONS ARE

LINEAR	RANGE	5 - 50	51 - 250	> 250
	TOL (MM)	±0.5	±1.5	±2.5
ANGULAR		± 1.5°		
SURFACE FINISH	SYMBOL	∇∇∇	∇∇	∇
	TOL (um)	0.025 to 1.6	1.6 to 8	8 to 25

REV	DATE	ALTERED	
		CHD/APPD	
ZONE			
REV	DATE	ALTERED	
		CHD/APPD	
ZONE			

		BHARAT HEAVY ELECTRICALS LTD. HEAVY PLATES & VESSELS PLANT VISAKHAPATNAM - 530012, INDIA.			
		DRAWN	ANAND	RESEARCH AND DEVELOPMENT	
CHECKED	S MANDAL	CUSTOMER	BHEL INTERNAL		
APPROVED	SRINIVAS	TITLE	CLAMPING STUDS-1		
SCALE	1:1	REF DRAWING NO	RD-SU30-F-A-00001		
ALL PROJECTIONS ARE IN FIRST ANGLE UNLESS OTHERWISE SPECIFIED 		YEAR OF ORDER	DRAWING NUMBER	REV.	
		--	RD-SU30-F-P-00008	00	
SHEET 1 OF 1			SIZE:	A3	

RD-SU30-F-P-00009

DRG NO:

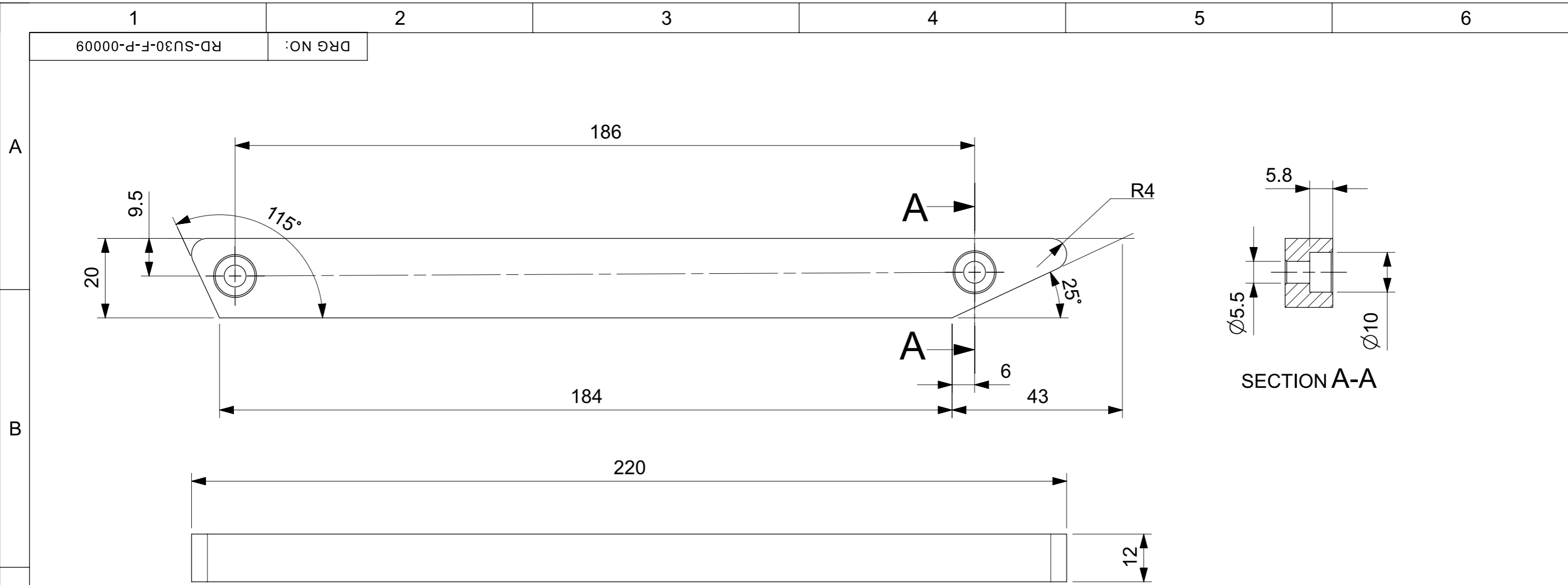

NOTES:
1. DEBURR ALL SHARP EDGES.

THE INFORMATION IN THIS DOCUMENT IS THE PROPERTY OF BHARAT HEAVY ELECTRICALS LIMITED. IT MUST NOT BE USED DIRECTLY OR INDIRECTLY IN ANY DETRIMENTAL TO INTEREST OF THE COMPANY

UNLESS OTHERWISE SPECIFIED TOLERANCES ON DIMENSIONS ARE				
LINEAR	RANGE	5 - 50	51 - 250	> 250
	TOL (MM)	±0.5	±1.5	±2.5
ANGULAR		± 1.5°		
SURFACE FINISH	SYMBOL	∇∇∇	∇∇	∇
	TOL (um)	0.025 to 1.6	1.6 to 8	8 to 25

REV	DATE	ALTERED	
		CHD/APPD	
ZONE			
REV	DATE	ALTERED	
		CHD/APPD	
ZONE			

		BHARAT HEAVY ELECTRICALS LTD. HEAVY PLATES & VESSELS PLANT VISAKHAPATNAM - 530012, INDIA.			
		DRAWN	ANAND	RESEARCH AND DEVELOPMENT	
CHECKED	S MANDAL	CUSTOMER	BHEL INTERNAL		
APPROVED	SRINIVAS	TITLE	STIFFENER		
SCALE	1:1		REF DRAWING NO	RD-SU30-F-A-00001	
ALL PROJECTIONS ARE IN FIRST ANGLE UNLESS OTHERWISE SPECIFIED		YEAR OF ORDER	DRAWING NUMBER	REV.	
		--	RD-SU30-F-P-00009	00	
SHEET 1 OF 1			SIZE: A3		

RD-SU30-F-P-00010

DRG NO:

R4 (TYP)

25°

43

6

186

184

9.5

20

12

220

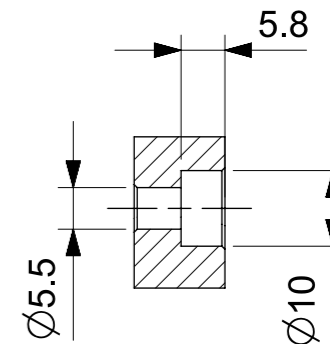

SECTION A-A

NOTES:

1. DEBURR ALL SHARP EDGES.

THE INFORMATION IN THIS DOCUMENT IS THE PROPERTY OF BHARAT HEAVY ELECTRICALS LIMITED. IT MUST NOT BE USED DIRECTLY OR INDIRECTLY IN ANY DETRIMENTAL TO INTEREST OF THE COMPANY

UNLESS OTHERWISE SPECIFIED TOLERANCES ON DIMENSIONS ARE

LINEAR	RANGE	5 - 50	51 - 250	> 250
	TOL (MM)	±0.5	±1.5	±2.5
ANGULAR		± 1.5°		
SURFACE FINISH	SYMBOL	∇∇∇	∇∇	∇
	TOL (um)	0.025 to 1.6	1.6 to 8	8 to 25

REV	DATE	ALTERED	
		CHD/APPD	
ZONE			
REV	DATE	ALTERED	
		CHD/APPD	
ZONE			

		BHARAT HEAVY ELECTRICALS LTD. HEAVY PLATES & VESSELS PLANT VISAKHAPATNAM - 530012, INDIA.			
		DRAWN	ANAND	RESEARCH AND DEVELOPMENT	
CHECKED	S MANDAL	CUSTOMER	BHEL INTERNAL		
APPROVED	SRINIVAS	TITLE	STIFFENER-1		
SCALE	1:1		REF DRAWING NO	RD-SU30-F-A-00001	
ALL PROJECTIONS ARE IN FIRST ANGLE UNLESS OTHERWISE SPECIFIED		YEAR OF ORDER	DRAWING NUMBER	REV.	
		--	RD-SU30-F-P-00010	00	
SHEET 1 OF 1			SIZE:	A3	

