

ALL DIMENSIONS ARE IN MILLIMETERS

3.2 / 1.6 / 0.8 /

DEVIATIONS OF UNTOLERANCED DIMENSIONS TO BE AS PER IS:2102-1969 MEDIUM

DETAIL-A (NTS)

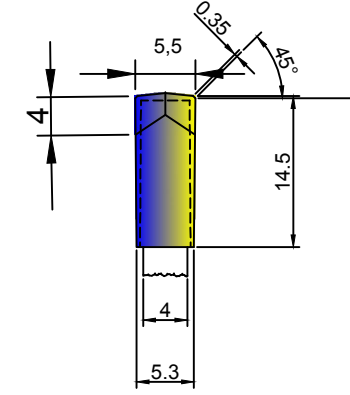
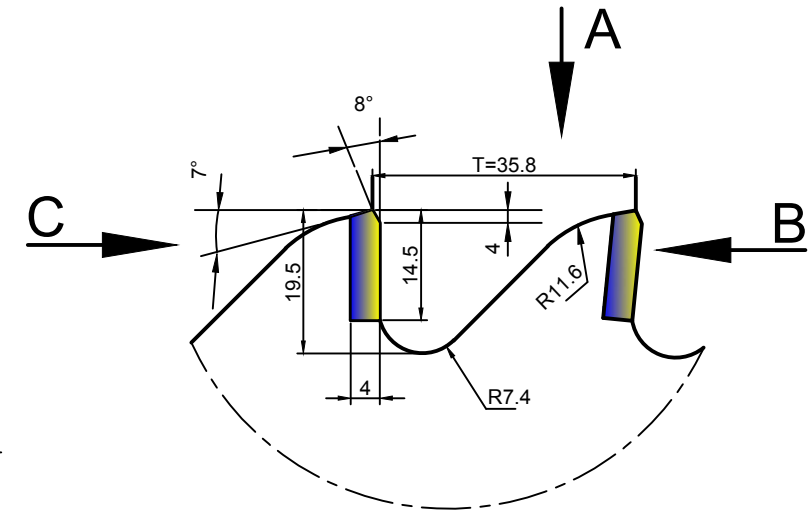

VIEW B

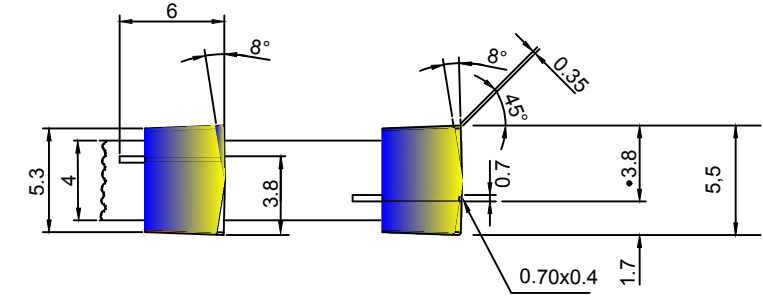

VIEW A

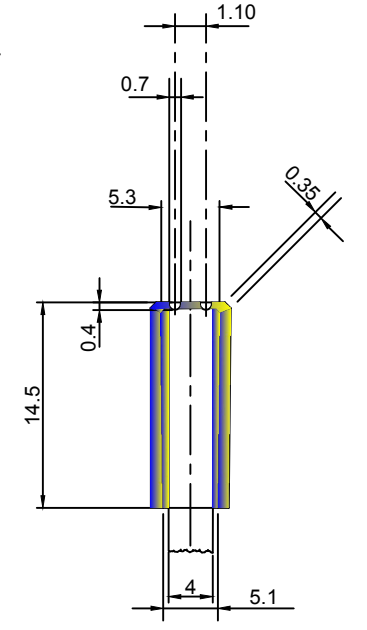

VIEW C

- NOTE :**
1. CHIP BREAKER POSITIONS CHANGE IN ALTERNATE TEETH
 2. BLADE SHOULD BE FREE FROM BEND

ITEM NO:01

BODY (DISK) MATERIAL: ANY ONE OF THE FOLLOWING MATERIAL SHALL BE USED.

- MATERIAL:
- 1) SKS 51 JADAN
 - 2) 75 Ni8 DIN 1.5634
 - 3) 1.2235, 80 CrV2

ITEM NO:02

TEETH MATERIAL
Carbide P25(Sand vik SM25)

MATERIAL CODE No:SP69 12 11 0003

REV	DATE	ALTERED :
01	06.03.17	APPROVED: M. Marudhavanan

EQPT:		Bharat Heavy Electricals Ltd SEAMLESS STEEL TUBE PLANT TIRUCHIRAPALLI - 620014		DRN	M. Bhawa	SIGNATURE	M. Marudhavanan	DATE	31/03/16
DEPT	SSTP/TE	GRADE OF UNTOL. DIM	SCALE	WEIGHT (Kg)	REF TO ASSY DWG NO	REF TO OLD DWG NO	ITEM		
456		φ/M/F IS:2102	NTS	-					
TITLE							CARD CODE	DRAWING NO :	REV
TCT SAW BLADE Ø730X64								30-ST-102-01-544	01